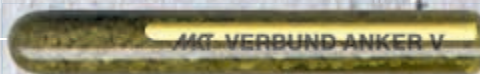
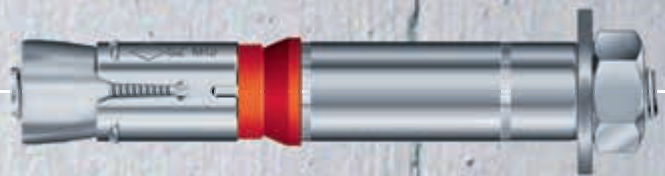


Product Range

2012

with Technical Data



... a solid connection

www.mkt.de

All technical details may be subject to change without notice.
We do not accept liability for printing mistakes or omissions.

For the latest technical data log on to our website www.mkt.de

MKT was founded in 1990 as a manufacturer of high quality, internationally approved fastening systems and certified in 1996 according to DIN EN ISO 9001. Meanwhile, MKT - products are used worldwide. The consistent orientation of the services offered to the needs of the market resulted in significantly above the industry average growth.

Please note that MKT also provides anchor sizes and designs beyond the standard product range, such as special solutions for tunnel constructions as well as stainless steel anchors from the materials 1.4529, 1.4571 and 1.4462.

MKT provides customer service on all technical questions anytime.

New:

→ Wedge Anchor BZ:

The Size M12 was replaced by a 33% higher tension load model. See page 8-13.

→ Highload Anchor SZ A4:

The tried and tested Highload Anchor SZ is now also available in stainless steel A4 including the ETA-020030 approval integrated. With its three types of headforms it now even offers outdoors high load mounting and immediate loading. See page 40-41.

→ Nail Anchor N:

The new Nail Anchor N with Hammerhead and connecting thread M6 opens new possibilities for fast and rational mounting. Simple hammering-in of the anchor is sufficient. All Nail Anchors are fire protection tested and carry ETA approval for redundant fastenings. See page 28-29.

→ Drop-In Anchor ES:

For the Drop-in Anchor E there is now a lipped shell model available (Drop-in Anchor ES). See page 30-31.

→ Injection Adhesive VM express:

The tried and tested Injection System VMU has now been extended by an even faster curing Adhesive VMU express. This is not only suitable for use in winter but also provides faster curing time in spring and autumn. Through the extension of the existing approvals the VMU and VMU express can be used at any time of year without restrictions. See page 66-73.





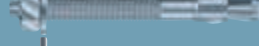
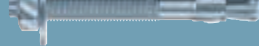




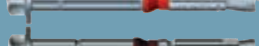
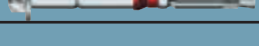
→ Injection Adhesive VM-Polar:

The new injection adhesive VM-Polar can be used in low temperatures. At the time of installation, the cartridge and building material temperature can be as low as -20°C. See page 88-93.



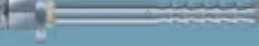
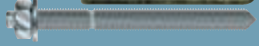

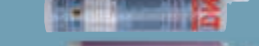
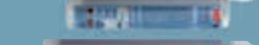
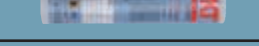


Table of Contents




Mechanical Heavy Duty Anchors

Wedge Anchor BZ plus		8 - 9
Wedge Anchor BZ plus A4		10-11
Wedge Anchor BZ plus HCR		12-13
Wedge Anchor BZ-IG / BZ-IG A4 / BZ-IG HCR		14-17
Wedge Anchor B / B A4 / B HCR / B hot dip galvanized		18-23
Wedge Anchor B-U / B-W		24-25
Wedge Anchor B-IG / B-IG A4		26-27
Nail Anchor N / N-K		28-29
Drop-in Anchor E / ES / ED / E A4 / E HCR		30-35
Hollow Core Anchor Easy		36-37
Highload Anchor SZ / SZ A4		38-41
Highload Anchor SL / SL A4		42-43

Chemical Anchors

Injection System VMZ / VMZ A4 / VMZ HCR		46-53
Injection System VMZ-IG / VMZ-IG A4		54-55
Injection System VMZ dynamic		56-59
Chemical Anchor V / V A4 / V HCR		60-63
Chemical Anchor V-IG / V-IG A4		64-65
Injection System VMU / VMU A4 / VMU HCR		66-73
Injection System VME		74-81
Injection System VM-K / VM-PY / VM-Polar		82-93

Light Duty Anchors

Nail Plug ND		96
Universal Plug UD		97
Safety Nail DZ		98
Drywall Plug GKD		99

Service

Design Software		102-103
Fire Resistance Reports		104-105

Approvals and Certificates



DIN EN ISO 9001 certification



European Technical Approval (ETA) with CE marking



Approval by 'Deutsches Institut für Bautechnik' in Berlin, Germany



ICC approval, United States of America



Shock approval by 'Bundesamt für Bevölkerungsschutz' in Bern, Switzerland



Factory Mutual (FM), U.S. approval for installation of sprinkler systems



Suitable for installation of sprinkler systems as per requirements of VdS Schadenverhütung GmbH, Germany



VdS Schadenverhütung GmbH, Germany, approval for installation of sprinkler systems in pre-stressed hollow concrete slabs



Test report stating residual load bearing capacities after exposure of anchor to open flames 30 to 120 minutes according to DIN 4102-2 (F30/R30, F60/R60, F90/R90, F120/R120)



Identifies anchors that are approved for fatigue loading





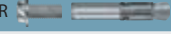
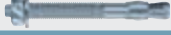
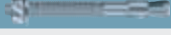
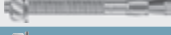
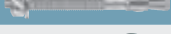





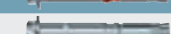


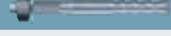

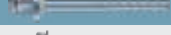
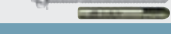
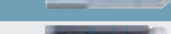










Material sign for stainless steel (A4 grade 316 or HCR material 1.4529)



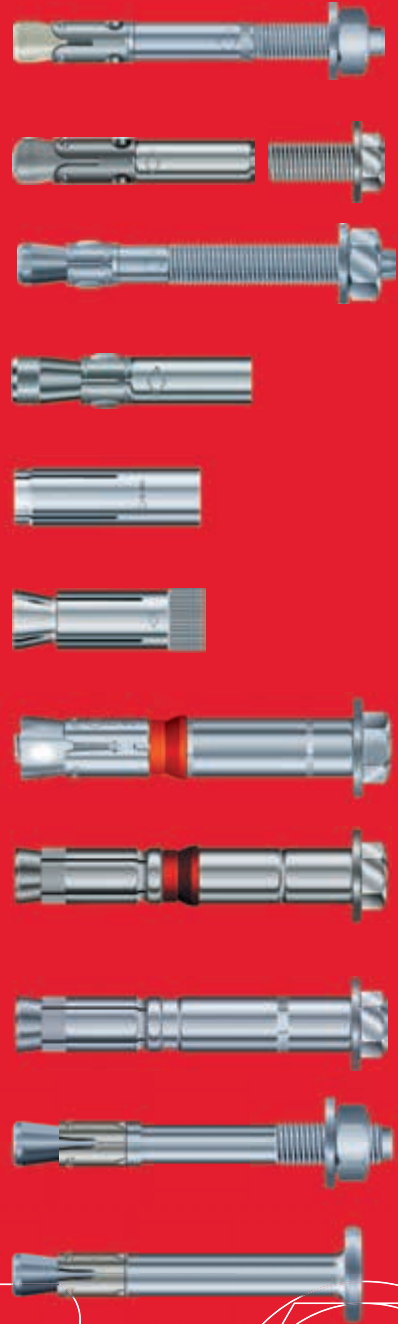
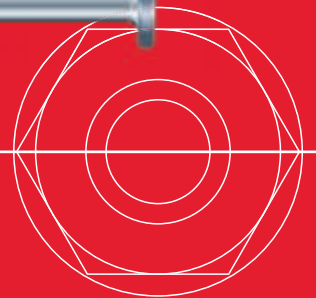
Included in MKT Design-Software

Anchor Selection

	Cracked Concrete	Non-cracked Concrete	Multiple Use in Concrete	Pre-stressed Concrete Hollow Slabs	Hollow Brick	Solid Brick	Drywall	ETA Approval	DIBt Approval	Fire Resistant	ICC approval	Approved for fatigue loading	VdS	FM	Swiss Shock Approval	Steel, Zinc Plated	Steel, Hot Dip Galvanized	Stainless Steel A4/316	Stainless Steel HCR	Design Software available
Mechanical Heavy Duty Anchors																				
Wedge Anchor BZ plus 	•	•						•	•			•	•	•	•					•
Wedge Anchor BZ plus A4 	•	•						•	•			•	•	•				•		•
Wedge Anchor BZ plus HCR 	•	•						•	•			•	•	•					•	•
Wedge Anchor BZ-IG 	•	•						•	•			•		•	•					•
Wedge Anchor BZ-IG A4 / HCR 	•	•						•	•			•		•				•	•	•
Wedge Anchor B 		•						•	•					•		•				•
Wedge Anchor B hot dip gal. 		•						•	•								•			•
Wedge Anchor B A4 		•	•					•	•	•			•	•				•		•
Wedge Anchor B HCR 			•					•	•										•	•
Wedge Anchor B-IG / B-IG A4 		•														•		•		•
Nail Anchor N, N-K 			•					•	•							•				•
Drop-in Anchor E, ES 		•	•					•	•				•	•		•				•
Drop-in Anchor E A4 / E HCR 		•	•					•	•				•	•				•	•	•
Hollow Core Anchor Easy 				•					•	•			•			•				•
Highload Anchor SZ / SZ A4 	•	•						•	•	•			•		•	•	•	•	•	•
Highload Anchor SL 		•						•	•							•				•
Highload Anchor SL A4 		•																•		•
Chemical Anchors																				
Injection System VMZ 	•	•						•	•						•	•	•	•	•	•
Injection System VMZ-IG 	•	•						•								•		•	•	•
Injection System VMZ dyn 	•	•							•			•				•			•	•
Chemical Anchor V 		•						•	•							•	•	•	•	•
Chemical Anchor V 		•														•		•		•
Injection System VMU 		•		•	•			•	•	•						•	•	•	•	•
Injection System VME 	•	•						•	•	•	•						•	•	•	•
Injection Adhesive VM-PY 				•	•				•							•	•	•	•	•
Injection Adhesive VM-K, Polar 		•		•	•											•	•	•	•	•
Light Duty Anchors																				
Nail Plug ND 		•		•	•											•				•
Universal Plug UD 		•		•	•	•														•
Safety Nail DZ 	•	•														•				•
Drywall Plug GKD 						•														•

Mechanical Heavy Duty Anchors





Wedge Anchor BZ plus

Steel, zinc plated



Wedge Anchor BZ plus

Wedge Anchor BZ plus M24

Description

The Wedge Anchor BZ plus (ETA, Option 1) combines high ultimate loads with close anchor spacing and edge distances. The special coating covering the expansion cone is heat resistant and durable enough to prevent cold welding of the expansion mechanism. This MKT patented invention also provides the proper friction between the stainless steel clip and the expansion cone throughout the entire service life of the anchor, which is a requirement for reliable crack-tested anchors.

New:

Upgraded version of the M12 size with nearly 33% higher tension load than before. The description „70M12“ is used to identify this improved version.

Applications

Medium to heavy duty anchoring in cracked and non-cracked concrete: Steel beams, base plates, channels, tracks, wood structures.

Range of Loading: 2,4 kN - 65,1 kN
Range of concrete quality: C20/25 - C50/60



Wedge Anchor BZ plus

- Steel, zinc plated
- Approved for cracked and non-cracked concrete



Description	Ref. No.	Drill Hole Øxdepth mm	Setting-depth mm	Fixture-thickness t _{fix} mm	Anchor-length l mm	Thread mm	Pkg. content pcs.	Weight per pkg. kg
BZ 8-10/75	06115101	8x60	52	10	75	M8x20	100	2,99
BZ 8-15/80	06120101	8x60	52	15	80	M8x25	100	3,14
BZ 8-30/95	06135101	8x60	52	30	95	M8x40	100	3,60
BZ 8-50/115	06145101	8x60	52	50	115	M8x60	100	4,24
BZ 8-100/165	06160101	8x60	52	100	165	M8x80	50	2,94
BZ 10-10/90	06210101	10x75	68	10	90	M10x20	50	2,94
BZ 10-15/95	06215101	10x75	68	15	95	M10x25	50	3,06
BZ 10-20/100	06220101	10x75	68	20	100	M10x30	50	3,18
BZ 10-30/110	06225101	10x75	68	30	110	M10x40	50	3,44
BZ 10-50/130	06235101	10x75	68	50	130	M10x60	50	4,95
BZ 10-75/155	06240101	10x75	68	75	155	M10x80	50	4,55
BZ 10-100/180	06250101	10x75	68	100	180	M10x80	50	5,16
BZ 10-150/230	06260101	10x75	68	150	230	M10x80	25	3,49
BZ 70 M12-15/110	06317101	12x90	80	15	110	M12x30	25	2,55
BZ 70 M12-20/115	06322101	12x90	80	20	115	M12x35	25	2,66
BZ 70 M12-30/125	06327101	12x90	80	30	125	M12x45	25	2,84
BZ 70 M12-50/145	06332101	12x90	80	50	145	M12x65	25	3,23
BZ 70 M12-65/160	06337101	12x90	80	65	160	M12x80	25	3,49
BZ 70 M12-85/180	06342101	12x90	80	85	180	M12x100	25	3,84
BZ 70 M12-105/200	06347101	12x90	80	105	200	M12x115	25	4,21
BZ 70 M12-125/220	06352101	12x90	80	125	220	M12x80	25	4,93
BZ 70 M12-145/240	06357101	12x90	80	145	240	M12x80	20	4,32
BZ 70 M12-160/255	06367101	12x90	80	160	255	M12x80	20	4,59
BZ 70 M12-190/285	06372101	12x90	80	190	285	M12x80	20	4,99
BZ 16-15/135	06510101	16x110	97	15	135	M16x35	20	4,32
BZ 16-25/145	06515101	16x110	97	25	145	M16x45	20	4,60
BZ 16-50/170	06520101	16x110	97	50	170	M16x70	20	5,26
BZ 16-80/200	06525101	16x110	97	80	200	M16x80	10	3,20
BZ 16-100/220	06530101	16x110	97	100	220	M16x80	10	3,50
BZ 16-140/260	06535101	16x110	97	140	260	M16x80	10	4,12
BZ 16-180/300	06540101	16x110	97	180	300	M16x80	10	4,74
BZ 20-30/165	06615101	20x125	114	30	165	M20x50	10	4,41
BZ 20-60/195	06625101	20x125	114	60	195	M20x70	10	5,05
BZ 20-100/235	06630101	20x125	114	100	235	M20x80	5	3,04
BZ 20-130/265	06635101	20x125	114	130	265	M20x80	5	3,43
BZ 20-150/285	06640101	20x125	114	150	285	M20x80	5	3,66
BZ 24-30/190	06715101	24x145	133	30	190	M24x55	10	6,85
BZ 24-60/220	06725101	24x145	133	60	220	M24x85	5	3,93
BZ 24-75/235	06735101	24x145	133	75	235	M24x100	5	4,15
BZ 24-100/260	06745101	24x145	133	100	260	M24x125	5	4,52

Other lengths on demand.

Wedge Anchor BZ-U plus

- With large washer DIN EN ISO 7093-1 (formerly: DIN 9021)
- Approved for cracked and non-cracked concrete



Description	Ref. No.	Drill Hole Øxdepth mm	Setting-depth mm	Fixture-thickness t _{fix} mm	Anchor-length l mm	Washer mm	Thread mm	Pkg. content pcs.	Weight per pkg. kg
BZ-U 8-10/75	06115701	8x60	52	10	75	24	M8x20	100	3,46
BZ-U 8-15/80	06120701	8x60	52	15	80	24	M8x25	100	3,52
BZ-U 8-30/95	06135701	8x60	52	30	95	24	M8x40	100	4,01
BZ-U 8-50/115	06145701	8x60	52	50	115	24	M8x60	100	4,63
BZ-U 10-10/90	06210701	10x75	68	10	90	30	M10x20	50	3,30
BZ-U 10-15/95	06215701	10x75	68	15	95	30	M10x25	50	3,45
BZ-U 10-20/100	06220701	10x75	68	20	100	30	M10x30	50	3,55
BZ-U 10-30/110	06225701	10x75	68	30	110	30	M10x40	50	3,95
BZ-U 10-50/130	06235701	10x75	68	50	130	30	M10x60	50	4,31
BZ-U 10-100/180	06250701	10x75	68	100	180	30	M10x80	50	6,02
BZ-U 10-150/230	06260701	10x75	68	150	230	30	M10x80	25	3,73
BZ-U 70 M12-15/110	06317701	12x90	80	15	110	37	M12x30	25	2,86
BZ-U 70 M12-30/125	06327701	12x90	80	30	125	37	M12x45	25	3,26
BZ-U 70 M12-50/145	06332701	12x90	80	50	145	37	M12x65	25	3,68
BZ-U 70 M12-125/220	06352701	12x90	80	125	220	37	M12x80	25	5,47
BZ-U 70 M12-160/255	06367701	12x90	80	160	255	37	M12x80	20	4,91
BZ-U 16-25/145	06515701	16x110	97	25	145	50	M16x45	20	5,15
BZ-U 16-100/220	06530701	16x110	97	100	220	50	M16x80	10	3,76
BZ-U 16-140/260	06535701	16x110	97	140	260	50	M16x80	10	4,50
BZ-U 16-180/300	06540701	16x110	97	180	300	50	M16x80	10	4,99
BZ-U 20-30/165	06615701	20x125	114	30	165	60	M20x50	10	4,98
BZ-U 20-60/195	06625701	20x125	114	60	195	60	M20x70	10	5,62
BZ-U 20-100/235	06630701	20x125	114	100	235	60	M20x80	5	3,31
BZ-U 20-130/265	06635701	20x125	114	130	265	60	M20x80	5	3,68
BZ-U 20-150/285	06640701	20x125	114	150	285	60	M20x80	5	3,92
BZ-U 24-30/190	06715701	24x145	133	30	190	72	M24x55	10	7,95
BZ-U 24-60/220	06725701	24x145	133	60	220	72	M24x85	5	5,05

Other lengths on demand.

new

new





Extract from Permissible Service Conditions of ETA-99/0010

Approved loads for single anchor without influence of spacing and edge distance.
Total safety factor as per ETAG 001 included (γ_{M} und γ_{P}).

new

Loads and performance data	Wedge Anchor BZ plus	M8	M10	70 M12	M16	M20	M24	
cracked concrete								
Mean ultimate loads, tension	C25/30 N_{um}	[kN]	10,5	14,7	28,0	35,1	79,8	
Mean ultimate loads, shear	C25/30 V_{um}	[kN]	19,0	26,9	40,5	73,3	157,7	
Approved loads, tension	C20/25 appr. N	[kN]	2,4	4,3	7,6	11,9	21,1	
	C25/30 appr. N	[kN]	2,6	4,7	8,3	13,1	23,3	
	C30/37 appr. N	[kN]	2,9	5,2	9,3	14,5	25,8	
	C40/50 appr. N	[kN]	3,4	6,0	10,8	16,8	29,8	
	C50/60 appr. N	[kN]	3,7	6,6	11,8	18,5	32,8	
non-cracked concrete								
Approved loads, tension	C20/25 appr. N	[kN]	5,7	7,6	11,9	16,7	29,6	
	C25/30 appr. N	[kN]	6,3	8,4	13,0	18,3	32,6	
	C30/37 appr. N	[kN]	7,0	9,3	14,5	20,3	36,1	
	C40/50 appr. N	[kN]	7,5	10,7	16,8	23,5	41,7	
	C50/60 appr. N	[kN]	7,5	11,8	18,4	25,8	45,9	
cracked / non-cracked concrete								
Approved loads, shear	C20/25 appr. V	[kN]	8,6	12,6	17,1	26,9/34,3	34,3/37,1	42,3/59,2
	\geq C25/30 appr. V	[kN]	8,6	12,6	17,1	29,6/34,3	37,1	46,5/65,1
Approved bending moments	appr. M	[Nm]	13,1	26,9	46,9	119,4	195,0	513,1

Spacing and edge distance

Effective anchorage depth	h_{ef}	[mm]	46	60	70	85	100	115
Characteristic spacing	$s_{cr,N}$	[mm]	138	180	210	255	300	345
Characteristic edge distance	$c_{cr,N}$	[mm]	69	90	105	127,5	150	172,5

Minimum spacing and edge distance for standard thickness of concrete member

cracked concrete								
Minimum spacing / for edge distance c	s_{min} / c	[mm]	40 / 70	45 / 70	60 / 100	60 / 100	95 / 150	100 / 180
Minimum edge distance / for spacing s	c_{min} / s	[mm]	40 / 80	45 / 90	60 / 140	60 / 180	95 / 200	100 / 220
non-cracked concrete								
Minimum spacing / for edge distance c	s_{min} / c	[mm]	40 / 80	45 / 70	60 / 120	65 / 120	90 / 180	100 / 180
Minimum edge distance / for spacing s	c_{min} / s	[mm]	50 / 100	50 / 100	75 / 150	80 / 150	130 / 240	100 / 220
Standard thickness of concrete slab	h_{std}	[mm]	100	120	140	170	200	230

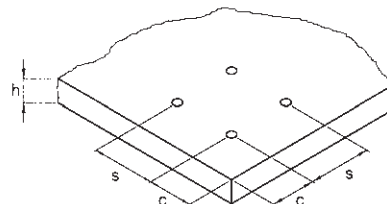
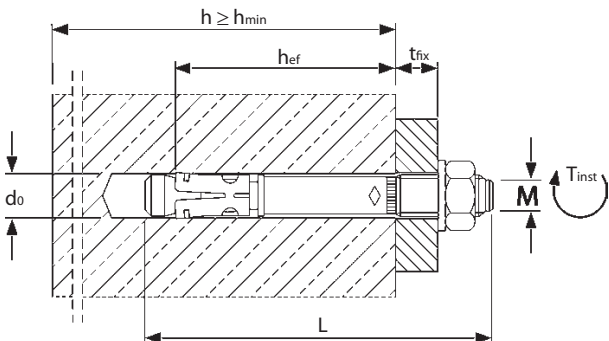
Minimum spacing and edge distance for minimum thickness of concrete member

cracked concrete								
Minimum spacing / for edge distance c	s_{min} / c	[mm]	40 / 70	45 / 90	60 / 100	70 / 160	-	-
Minimum edge distance / for spacing s	c_{min} / s	[mm]	40 / 80	50 / 115	60 / 140	80 / 180	-	-
non-cracked concrete								
Minimum spacing / for edge distance c	s_{min} / c	[mm]	40 / 80	60 / 140	60 / 120	80 / 180	-	-
Minimum edge distance / for spacing s	c_{min} / s	[mm]	50 / 100	90 / 140	75 / 150	90 / 200	-	-
Minimum thickness of concrete slab	h_{min}	[mm]	80	100	120	140	-	-

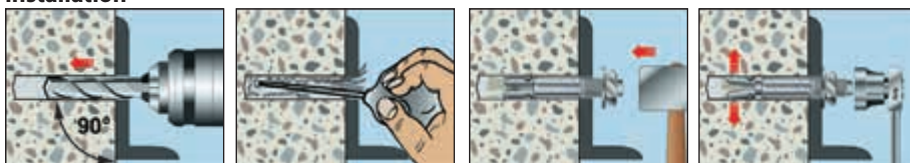
Installation parameters

Drill hole diameter	d_o	[mm]	8	10	12	16	20	24
Diameter of clearance hole in the fixture	d_r	[mm]	9	12	14	18	22	26
Depth of drill hole	h_1	[mm]	60	75	90	110	125	145
Installation torque	T_{inst}	[Nm]	20	25	45	90	160	200
Width across nut	SW	[mm]	13	17	19	24	30	36

For anchor designing, an easy to operate CD-ROM is available on request or can be downloaded at www.mkt.de



Installation



Wedge Anchor BZ plus A4

Stainless Steel A4/316



Wedge Anchor BZ plus A4

Wedge Anchor BZ-U plus A4



Description

The Wedge Anchor BZ plus A4 (ETA, Option 1) combines high ultimate loads with close anchor spacing and edge distances. The special coating covering the expansion cone is heat resistant and durable enough to prevent cold welding of the expansion mechanism. This MKT patented invention also provides the proper friction between the stainless steel clip and the expansion cone throughout the entire service life of the anchor, which is a requirement for reliable crack-tested anchors.

New:

Upgraded version of the M12 size with nearly 33% higher tension load than before. The description „70M12“ is used to identify this improved version.

Applications

Medium to heavy duty anchoring in cracked and non-cracked concrete: Steel beams, channels, facade substructures, chairs in sports arenas, wood structures.



Range of Loading: 2,4 kN - 43,9 kN

Range of concrete quality: C20/25 - C50/60



Wedge Anchor BZ plus A4

→ Stainless steel A4/316

→ Approved for cracked and non-cracked concrete



Wedge Anchor BZ-U plus A4

→ With large washer DIN EN ISO 7093-1 (formerly DIN 9021)

→ Approved for cracked and non-cracked concrete



Description	Ref. No.	Drill Hole Øxdepth mm	Set-ting-depth mm	Fixture-thickness t _{fix} mm	Anchoring-length l mm	Thread mm	Pkg. content pcs.	Weight per pkg. kg
BZ 8-10/75 A4	02115501	8x60	54	10	75	M8x20	100	3,02
BZ 8-15/80 A4	02120501	8x60	54	15	80	M8x25	100	3,16
BZ 8-30/95 A4	02135501	8x60	54	30	95	M8x40	100	3,68
BZ 8-50/115 A4	02145501	8x60	54	50	115	M8x60	100	4,34
BZ 10-10/90 A4	02210501	10x75	68	10	90	M10x20	50	2,97
BZ 10-15/95 A4	02215501	10x75	68	15	95	M10x25	50	3,12
BZ 10-30/110 A4	02225501	10x75	68	30	110	M10x40	50	3,48
BZ 10-50/130 A4	02235501	10x75	68	50	130	M10x60	50	4,02
BZ 10-100/180 A4	02250501	10x75	68	100	180	M10x80	50	5,26
BZ 70 M12-15/110 A4	02317501	12x90	80	15	110	M12x30	25	2,55
BZ 70 M12-20/115 A4	02322501	12x90	80	20	115	M12x35	25	2,66
BZ 70 M12-30/125 A4	02327501	12x90	80	30	125	M12x45	25	2,84
BZ 70 M12-50/145 A4	02332501	12x90	80	50	145	M12x65	25	3,23
BZ 70 M12-85/180 A4	02342501	12x90	80	85	180	M12x100	25	3,84
BZ 70 M12-125/220 A4	02352501	12x90	80	125	220	M12x80	25	4,93
BZ 70 M12-160/255 A4	02367501	12x90	80	160	255	M12x80	20	4,59
BZ 70 M12-190/285 A4	02372501	12x90	80	190	285	M12x80	20	4,99
BZ 16-25/145 A4	02515501	16x110	97	25	145	M16x45	20	4,68
BZ 16-50/170 A4	02520501	16x110	97	50	170	M16x70	20	5,36
BZ 16-100/220 A4	02530501	16x110	97	100	220	M16x80	10	3,59
BZ 20-30/165 A4	02615501	20x125	114	30	165	M20x50	10	4,51
BZ 20-60/195 A4	02625501	20x125	114	60	195	M20x70	10	5,14
BZ 20-100/235 A4	02630501	20x125	114	100	235	M20x80	5	3,09
BZ 20-130/265 A4	02635501	20x125	114	130	265	M20x80	5	3,48
BZ 20-150/285 A4	02640501	20x125	114	150	285	M20x80	5	3,73

Other lengths on demand.

Description	Ref. No.	Drill Hole Øxdepth mm	Set-ting-depth mm	Fixture-thickness t _{fix} mm	Anchoring-length l mm	Ø Washer mm	Thread mm	Pkg. content pcs.	Weight per pkg. kg
BZ-U 8-10/75 A4	02115541	8x60	54	10	75	24	M8x20	100	3,46
BZ-U 8-15/80 A4	02120541	8x60	54	15	80	24	M8x25	100	3,60
BZ-U 8-30/95 A4	02135541	8x60	54	30	95	24	M8x40	100	4,09
BZ-U 8-50/115 A4	02145541	8x60	54	50	115	24	M8x60	100	4,74
BZ-U 10-10/90 A4	02210541	10x75	68	10	90	30	M10x20	50	3,37
BZ-U 10-15/95 A4	02215541	10x75	68	15	95	30	M10x25	50	3,53
BZ-U 10-30/110 A4	02225541	10x75	68	30	110	30	M10x40	50	3,94
BZ-U 10-50/130 A4	02235541	10x75	68	50	130	30	M10x60	50	4,70
BZ-U 70 M12-15/110 A4	02317541	12x90	80	15	110	37	M12x30	25	2,86
BZ-U 70 M12-30/125 A4	02327541	12x90	80	30	125	37	M12x35	25	3,26
BZ-U 70 M12-50/145 A4	02332541	12x90	80	50	145	37	M12x65	25	3,68
BZ-U 70 M12-125/220 A4	02352541	12x90	80	125	220	37	M12x80	25	5,47
BZ-U 70 M12-160/255A4	02367541	12x90	80	160	255	37	M12x80	20	4,91
BZ-U 70 M12-190/285A4	02372541	12x90	80	180	275	37	M12x80	20	4,99
BZ-U 16-25/145 A4	02515541	16x110	97	25	145	50	M16x45	20	5,59
BZ-U 16-100/220 A4	02530541	16x110	97	100	220	50	M16x80	10	4,01
BZ-U 20-30/165 A4	02615541	20x125	114	30	165	60	M20x50	10	4,70
BZ-U 20-60/195 A4	02625541	20x125	114	60	195	60	M20x70	10	5,80
BZ-U 20-100/235 A4	02630541	20x125	114	100	235	60	M20x80	5	3,09
BZ-U 20-130/265 A4	02635541	20x125	114	130	265	60	M20x80	5	3,68
BZ-U 20-150/285 A4	02640541	20x125	114	150	285	60	M20x80	5	3,92

Other lengths on demand.

new

new



Extract from Permissible Service Conditions of ETA-99/0010

Approved loads for single anchor without influence of spacing and edge distance.
Total safety factor as per ETAG 001 included (γ_M und γ_p).

new

Loads and performance data	Wedge Anchor BZ plus A4	M8	M10	70 M12	M16	M20	
cracked concrete							
Mean ultimate loads, tension	C25/30 N_{um}	[kN]	10,8	16,7	28,0	40,0	54,3
Mean ultimate loads, shear	C25/30 V_{um}	[kN]	18,4	32,9	35,5	85,8	121,5
Approved loads, tension	C20/25 appr. N	[kN]	2,4	4,3	7,6	11,9	17,1
	C25/30 appr. N	[kN]	2,6	4,7	8,3	13,1	18,9
	C30/37 appr. N	[kN]	2,9	5,2	9,3	14,5	20,9
	C40/50 appr. N	[kN]	3,4	6,0	10,8	16,8	24,2
	C50/60 appr. N	[kN]	3,7	6,6	11,8	18,5	26,6
non-cracked concrete							
Approved loads, tension	C20/25 appr. N	[kN]	5,7	7,6	11,9	16,7	24,0
	C25/30 appr. N	[kN]	6,3	8,4	13,0	18,3	26,4
	C30/37 appr. N	[kN]	7,0	9,3	14,5	20,3	29,3
	C40/50 appr. N	[kN]	7,6	10,7	16,8	23,5	33,8
	C50/60 appr. N	[kN]	7,6	11,8	18,4	25,8	37,2
cracked / non-cracked concrete							
Approved loads, shear	C20/25 appr. V	[kN]	7,4	11,4	17,1	26,9/31,4	34,3/43,9
	\geq C25/30 appr. V	[kN]	7,4	11,4	17,1	29,6/31,4	37,7/43,9
Approved bending moments	appr. M	[Nm]	14,9	29,7	52,6	133,1	231,6

Spacing and edge distance

Effective anchorage depth	h_{ef}	[mm]	46	60	70	85	100
Characteristic spacing	$s_{cr,N}$	[mm]	138	180	210	255	300
Characteristic edge distance	$c_{cr,N}$	[mm]	69	90	105	127,5	150

Minimum spacing and edge distance for standard thickness of concrete member

cracked concrete							
Minimum spacing / for edge distance c	s_{min} / c	[mm]	40 / 70	50 / 75	60 / 100	60 / 100	95 / 150
Minimum edge distance / for spacing s	c_{min} / s	[mm]	40 / 80	55 / 90	60 / 140	60 / 180	95 / 200
non-cracked concrete							
Minimum spacing / for edge distance c	s_{min} / c	[mm]	40 / 80	50 / 75	60 / 120	65 / 120	90 / 180
Minimum edge distance / for spacing s	c_{min} / s	[mm]	50 / 100	60 / 120	75 / 150	80 / 150	130 / 240
Standard thickness of concrete slab	h_{std}	[mm]	100	120	140	160	200

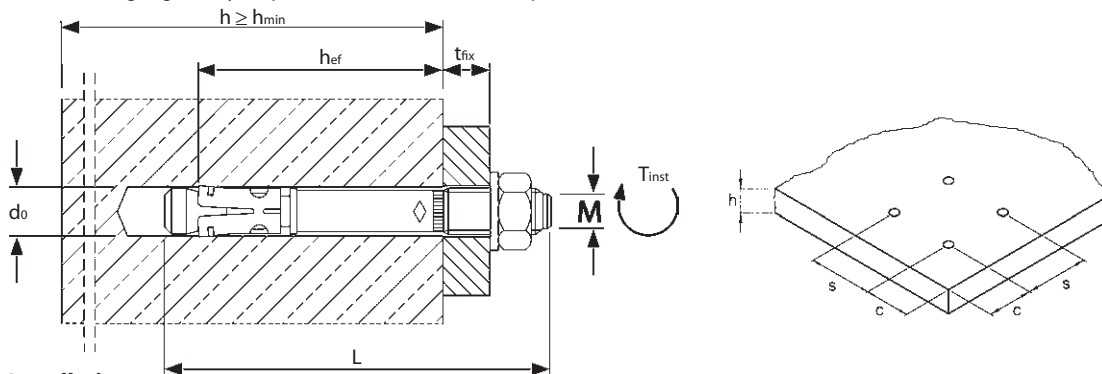
Minimum spacing and edge distance for minimum thickness of concrete member

cracked concrete							
Minimum spacing / for edge distance c	s_{min} / c	[mm]	40 / 70	45 / 90	60 / 100	70 / 160	95 / 150
Minimum edge distance / for spacing s	c_{min} / s	[mm]	40 / 80	50 / 115	60 / 140	80 / 180	95 / 200
non-cracked concrete							
Minimum spacing / for edge distance c	s_{min} / c	[mm]	40 / 80	60 / 140	60 / 120	80 / 180	90 / 180
Minimum edge distance / for spacing s	c_{min} / s	[mm]	50 / 100	90 / 140	75 / 150	90 / 200	130 / 240
Minimum thickness of concrete slab	h_{min}	[mm]	80	100	120	140	200

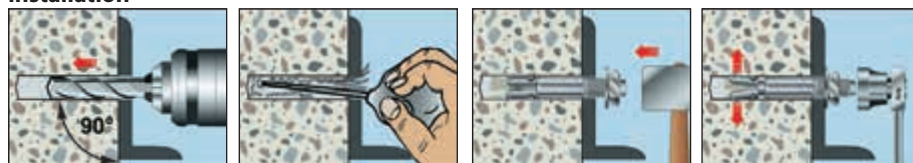
Installation parameters

Drill hole diameter	d_o	[mm]	8	10	12	16	20
Diameter of clearance hole in the fixture	d_f	[mm]	9	12	14	18	22
Depth of drill hole	h_1	[mm]	60	75	90	110	125
Installation torque	T_{inst}	[Nm]	20	35	50	110	200
Width across nut	SW	[mm]	13	17	19	24	30

For anchor designing, an easy to operate CD-ROM is available on request or can be downloaded at www.mkt.de.



Installation



Mechanical Heavy Duty Anchors

Wedge Anchor BZ plus HCR

High corrosion resistant steel 1.4529 (HCR)



Description

The Wedge Anchor BZ plus HCR (ETA, Option 1) combines high approved loads with close anchor spacing and edge distances. Time saving through fastening installations - no special drilling and setting tools are required. Tightening the hexagon nut expands the sleeve which produces permanent grip in cracked and non-cracked concrete. The BZ plus HCR is BZS shock approved.

New:

Upgraded version of the M12 size with nearly 33% higher tension load than before. The description „70M12“ is used to identify this improved version.



Applications

Medium to heavy duty anchorings which are exposed to highly corrosive atmospheres with high concentration of sulphur dioxides, chlorides, humidity: attaching brackets, ventilation systems, suspended ceilings, cable trays, in road tunnels, indoor swimming pools, etc.

Range of Loading: 2,4 kN - 43,9 kN

Range of concrete quality: C20/25 - C50/60



Wedge Anchor BZ plus HCR

→ High corrosion resistant steel 1.4529 (HCR)

→ Approved for cracked and non-cracked concrete



Description	Ref. No.	Drill Hole Øxdepth	Setting- depth	Fixture- thickness t _{fix}	Anchor- length l	Thread	Pkg. content pcs.	Weight per pkg. kg
		mm	mm	mm	mm	mm		
BZ 8-10/75 HCR	02115651	8 x 60	54	10	75	M8x20	100	3,08
BZ 8-15/80 HCR	02120651	8 x 60	54	15	80	M8x25	100	3,22
BZ 8-30/95 HCR	02135651	8 x 60	54	30	95	M8x40	100	3,72
BZ 8-50/115 HCR	02145651	8 x 60	54	50	115	M8x60	100	4,35
BZ 10-10/90 HCR	02210651	10 x 75	68	10	90	M10x20	50	3,02
BZ 10-15/95 HCR	02215651	10 x 75	68	15	95	M10x25	50	3,14
BZ 10-30/110 HCR	02225651	10 x 75	68	30	110	M10x40	50	3,90
BZ 10-50/130 HCR	02235651	10 x 75	68	50	130	M10x60	50	4,31
BZ 70 M12-15/110 HCR	02317651	12 x 90	80	15	110	M12x30	25	2,55
BZ 70 M12-20/115 HCR	02320651	12 x 90	80	20	115	M12x35	25	2,66
BZ 70 M12-50/145 HCR	02332651	12 x 90	80	50	145	M12x65	25	2,23
BZ 70 M12-125/220 HCR	02352651	12 x 90	80	125	220	M12x80	25	4,93
BZ 16-25/145 HCR	02515651	16 x 110	97	25	145	M16x45	20	4,90
BZ 16-50/170 HCR	02520651	16 x 110	97	50	170	M16x70	20	5,80
BZ 16-100/220 HCR	02530651	16 x 110	97	100	220	M16x80	10	3,70
BZ 20-30/165 HCR	02615651	20 x 125	114	30	165	M20x50	10	4,95
BZ 20-60/195 HCR	02625651	20 x 125	114	60	195	M20x70	10	5,14
BZ 20-100/235 HCR	02630651	20 x 125	114	100	235	M20x80	5	3,18
BZ 20-130/265 HCR	02635651	20 x 125	114	130	265	M20x80	5	3,48
BZ 20-150/285 HCR	02640651	20 x 125	114	150	285	M20x80	5	3,73

Other lengths on demand.

new



Extract from Permissible Service Conditions of ETA-99/0010

Approved loads for single anchor without influence of spacing and edge distance.
Total safety factor as per ETAG 001 included (γ_M und γ_P).

new

Loads and performance data	Wedge Anchor BZ plus HCR	M8	M10	70 M12	M16	M20
cracked concrete						
Mean ultimate loads, tension	C25/30 N_{um} [kN]	10,8	16,7	28,0	40,0	54,3
Mean ultimate loads, shear	C25/30 V_{um} [kN]	18,4	32,9	35,5	74,6	121,5
Approved loads, tension	C20/25 appr. N [kN]	2,4	4,3	7,6	11,9	17,1
	C25/30 appr. N [kN]	2,6	4,7	8,3	13,1	18,9
	C30/37 appr. N [kN]	2,9	5,2	9,3	14,5	20,9
	C40/50 appr. N [kN]	3,4	6,0	10,8	16,8	24,2
	C50/60 appr. N [kN]	3,7	6,6	11,8	18,5	26,6
non-cracked concrete						
Approved loads, tension	C20/25 appr. N [kN]	5,7	7,6	11,9	16,7	24,0
	C25/30 appr. N [kN]	6,3	8,4	13,0	18,3	26,4
	C30/37 appr. N [kN]	7,0	9,3	14,5	20,3	29,3
	C40/50 appr. N [kN]	7,6	10,7	16,8	23,5	33,8
	C50/60 appr. N [kN]	7,6	11,8	18,4	25,8	37,2
cracked and non-cracked concrete						
Approved loads, shear	C20/25 appr. V [kN]	7,4	11,4	17,1	26,9/31,4	34,3/43,9
	\geq C25/30 appr. V [kN]	7,4	11,4	17,1	29,6/31,4	37,7/43,9
Approved bending moments	appr. M [Nm]	14,9	29,7	52,6	133,1	231,6

Spacing and edge distance

Effective anchorage depth	h_{ef} [mm]	46	60	70	85	100
Characteristic spacing	$s_{cr,N}$ [mm]	138	180	210	255	300
Characteristic edge distance	$c_{cr,N}$ [mm]	69	90	105	127,5	150

Minimum spacing and edge distance for standard thickness of concrete member

cracked concrete						
Minimum spacing / for edge distance c	s_{min} / c [mm]	40/70	50/75	60/100	60/100	95/150
Minimum edge distance / for spacing s	c_{min} / s [mm]	40/80	55/90	60/140	60/180	95/200
non-cracked concrete						
Minimum spacing / for edge distance c	s_{min} / c [mm]	40/80	50/75	60/120	65/120	90/180
Minimum edge distance / for spacing s	c_{min} / s [mm]	50/100	60/120	75/150	80/150	130/240
Standard thickness of concrete slab	h_{std} [mm]	100	120	140	160	200

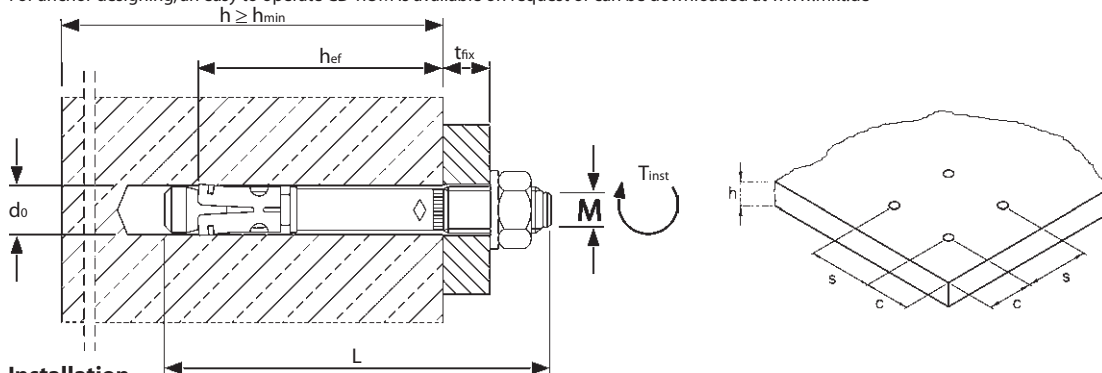
Minimum spacing and edge distance for minimum thickness of concrete member

cracked concrete						
Minimum spacing / for edge distance c	s_{min} / c [mm]	40/70	45/90	60/100	70/160	95/150
Minimum edge distance / for spacing s	c_{min} / s [mm]	40/80	50/115	60/140	80/180	95/200
non-cracked concrete						
Minimum spacing / for edge distance c	s_{min} / c [mm]	40/80	60/140	60/120	80/180	90/180
Minimum edge distance / for spacing s	c_{min} / s [mm]	50/100	90/140	75/150	90/200	130/240
Minimum thickness of concrete slab	h_{min} [mm]	80	100	120	140	200

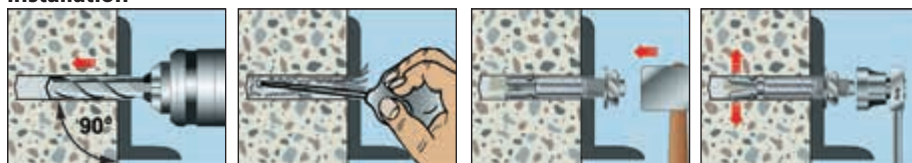
Installation parameters

Drill hole diameter	d_o [mm]	8	10	12	16	20
Diameter of clearance hole in the fixture	d_f [mm]	9	12	14	18	22
Depth of drill hole	h_1 [mm]	60	75	90	110	125
Installation torque	T_{inst} [Nm]	20	35	50	110	200
Width across nut	SW [mm]	13	17	19	24	30

For anchor designing, an easy to operate CD-ROM is available on request or can be downloaded at www.mkt.de

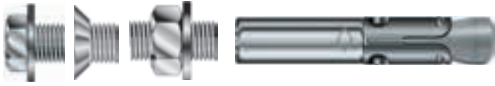


Installation



Wedge Anchor BZ-IG

Steel, zinc plated

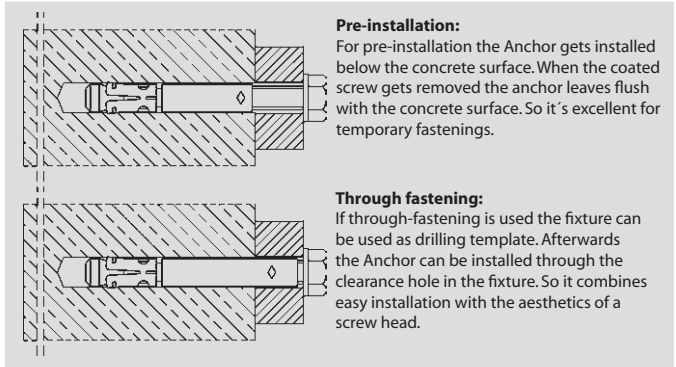


Description

The fastening system BZ-IG is the first approved (ETA-02/0002) wedge anchor for cracked concrete with internal thread. It combines the benefits of a mechanical anchor with an easy installation and the flexibility of an internal thread. For the first time it is possible to fasten balcony and stair railings or stadium seats using a countersunk head screw at favourable costs. Since this anchor system is also approved for use with hexagon head screws and standard threaded rods a wide range of applications is possible. Compared to a drop in anchor the fastening system BZ-IG can carry significant higher loads, even in cracked concrete. The versatility of the MKT Fastening System BZ-IG breaks new ground in design and application.

Applications:

Medium to heavy duty fastenings in cracked and non-cracked concrete: Railings, suspended ceilings, ladders, doors, sprinkler systems, pipe hangers and all kinds of temporary fastenings.



Range of Loading: 2,0 kN - 18,5 kN

Range of concrete quality: C20/25 - C50/60

Pre-Installation

Wedge Anchor BZ-IG¹⁾



→ Steel, zinc plated; Pre-Installation

→ Approved for cracked and non-cracked concrete

Description	Ref. No.	Drill Hole Øxdepth	Anchor-length	Thread Ø x length	Weight per pkg.	pkg. content
		mm	mm	mm	kg	pcs.
BZ-IG M 6-0	03600101	8 x 60	50	M6x20	1,42	100
BZ-IG M 8-0	03610101	10 x 75	62	M8x22	1,31	50
BZ-IG M 10-0	03620101	12 x 90	70	M10x23	1,08	25
BZ-IG M 12-0	03630101	16 x 105	86	M12x27	2,03	20

Coated Screw DIN 933 with Washer DIN EN ISO 7089 (DIN 125)¹⁾

Description	Ref. No.	Fixture-thickn. t _{fix} mm	Wght. per pkg. kg	Pkg. content pcs.
S-IG 6x25	54010101	4-12	0,80	100
S-IG 8x25	54110101	2-8	0,79	50
S-IG 10x40	54210101	15-19	0,90	25
S-IG 12x45	54310101	16-21	1,13	20

Setting Tool BZ-IG for Pre-Installation

Description	Ref. No.	Wght. per pkg. kg
BZ-IGS M 6V	43005150	0,43
BZ-IGS M 8V	43100150	0,44
BZ-IGS M 10V	43200150	0,46
BZ-IGS M 12V	43300150	0,56

Coated Countersunk Screw DIN 7991 with Countersunk Washer¹⁾

Description	Ref. No.	Fixture-thickn. t _{fix} mm	Wght. per pkg. kg	Pkg. content pcs.
SK-IG 6x25	55013101	6-14	0,53	100
SK-IG 8x30	55112101	9-15	0,59	50
SK-IG 10x30	55211101	8-11	0,48	25
SK-IG 12x35	55311101	9-14	0,64	20

Coated Hex Nut DIN 933 with Washer DIN EN ISO 7089 (DIN 125)¹⁾

Description	Ref. No.	Wght. per pkg. kg	Pkg. content pcs
MU-IG 6	56005101	0,32	100
MU-IG 8	56105101	0,35	50
MU-IG 10	56205101	0,36	25
MU-IG 12	56305101	0,45	20

¹⁾ Screws (Strength class 8.8) or hex nuts and washers to be ordered separately. Other screw lengths according to DIN 933 on demand. Threaded stud must have at least the strength of 8.8. Threaded studs with the certificate see page 71.



Through Fastening

Wedge Anchor BZ-IG¹⁾



→ Steel, zinc plated; Through Fastening

→ Approved for cracked and non-cracked concrete

Description	Ref. No.	Drill Hole Øxdepth	Fixture-thickness t _{fix} mm	Anchor-length l mm	Thread Ø x length mm	Weight per pkg. kg	pkg. content pcs
		mm	Typ S-IG mm	Typ SK-IG mm			
BZ-IG M 6-10	03602101	8 x 60	10	14	60 M6 x 20	1,80	100
BZ-IG M 6-20	03604101	8 x 60	20	24	70 M6 x 20	2,20	100
BZ-IG M 6-30	03606101	8 x 60	30	34	80 M6 x 20	2,60	100
BZ-IG M 8-10	03611101	10 x 75	10	15	72 M8 x 22	1,65	50
BZ-IG M 8-20	03612101	10 x 75	20	25	82 M8 x 22	1,95	50
BZ-IG M 8-30	03613101	10 x 75	30	35	92 M8 x 22	2,25	50
BZ-IG M 10-10	03621101	12 x 90	10	16	80 M10 x 23	1,32	25
BZ-IG M 10-20	03622101	12 x 90	20	26	90 M10 x 23	1,48	25
BZ-IG M 10-30	03623101	12 x 90	30	36	100 M10 x 23	1,76	25
BZ-IG M 12-10	03631101	16 x 105	10	17	96 M12 x 27	2,34	20
BZ-IG M 12-20	03632101	16 x 105	20	27	106 M12 x 27	2,66	20
BZ-IG M 12-30	03633101	16 x 105	30	37	116 M12 x 27	2,97	20

Setting Tool BZ-IG for Through Fastening

Description	Ref. No.	Weight per package kg
BZ-IGS M 6D	43005155	0,32
BZ-IGS M 8D	43100155	0,33
BZ-IGS M 10D	43200155	0,33
BZ-IGS M 12D	43300155	0,35

Coated Screw DIN 933 with Washer DIN EN ISO 7089 (DIN 125)¹⁾

Description	Ref. No.	Wght. per pkg. kg	Pkg. content pcs
S-IG 6x16	54020101	0,64	100
S-IG 8x18	54120101	0,68	50
S-IG 10x20	54220101	0,64	25
S-IG 12x25	54320101	0,67	20

Coated Countersunk Screw DIN 7991 with Countersunk Washer¹⁾

Description	Ref. No.	Wght. per pkg. kg	Pkg. content pcs
SK-IG 6x16	55010101	0,64	100
SK-IG 8x20	55110101	0,60	50
SK-IG 10x25	55210101	0,62	25
SK-IG 12x30	55310101	0,80	20

¹⁾ Screws (Strength class 8.8) to be ordered separately.



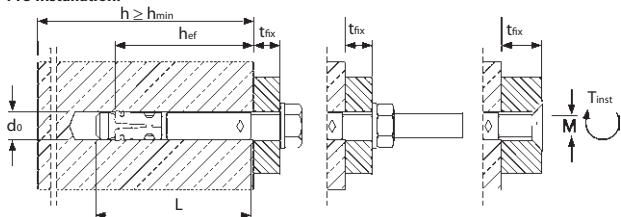
Extract from Permissible Service Conditions of ETA-02/0002

Approved loads for single anchor without influence of spacing and edge distance.
Total safety factor as per ETAG 001 included (γ_M und γ_p).

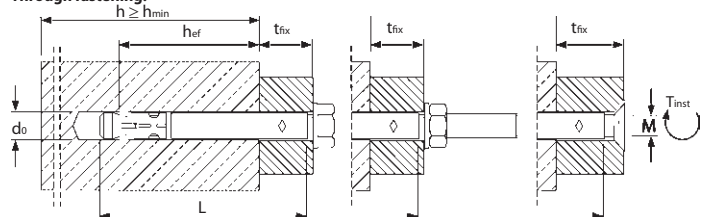
Loads and performance data	Wedge Anchor BZ-IG		M 6	M 8	M 10	M 12	
cracked concrete							
Mean ultimate loads, tension	C25/30	N_{um}	[kN]	14,1	19,8	28,3	45,9
Mean ultimate loads, shear	C25/30	V_{um}	[kN]	8,7	11,4	14,8	33,9
Approved loads, tension	C20/25	appr. N	[kN]	2,0	3,6	4,8	7,9
	C25/30	appr. N	[kN]	2,2	3,9	5,2	8,7
	C30/37	appr. N	[kN]	2,4	4,4	5,8	9,7
	C40/50	appr. N	[kN]	2,8	5,0	6,7	11,2
	C50/60	appr. N	[kN]	3,1	5,5	7,4	12,3
non-cracked concrete							
Approved loads, tension	C20/25	appr. N	[kN]	4,8	6,3	7,9	11,9
	C25/30	appr. N	[kN]	5,2	7,0	8,7	13,1
	C30/37	appr. N	[kN]	5,8	7,7	9,7	14,5
	C40/50	appr. N	[kN]	6,7	9,0	11,2	16,8
	C50/60	appr. N	[kN]	7,4	9,8	12,3	18,5
cracked and non-cracked concrete							
Approved loads, shear (Pre-Installation)	\geq C20/25	appr. V	[kN]	3,3	3,9	5,9	14,7
Approved loads, shear (Through Fastening)	\geq C20/25	appr. V	[kN]	2,9	4,3	6,2	13,9
Approved bending moments (Pre-Installation)		appr. M	[Nm]	7,0	17,1	34,2	59,8
Approved bending moments (Through Fastening)		appr. M	[Nm]	20,6	30,4	43,4	118,3
Spacing and edge distance							
Effective anchorage depth	h_{ef}	[mm]	45	58	65	80	
Characteristic spacing	$s_{cr,N}$	[mm]	135	174	195	240	
Characteristic edge distance	$c_{cr,N}$	[mm]	67,5	87	97,5	120	
cracked concrete							
Minimum spacing / for edge distance c	s_{min} / c	[mm]	50 / 60	60 / 80	70 / 100	80 / 120	
Minimum edge distance / for spacing s	c_{min} / s	[mm]	50 / 75	60 / 100	70 / 100	80 / 120	
non-cracked concrete							
Minimum spacing / for edge distance c	s_{min} / c	[mm]	50 / 80	60 / 100	65 / 120	80 / 160	
Minimum edge distance / for spacing s	c_{min} / s	[mm]	50 / 115	60 / 155	70 / 170	100 / 210	
Minimum thickness of concrete slab	h_{min}	[mm]	100	120	130	160	
Installation parameters							
Drill hole diameter	d_o	[mm]	8	10	12	16	
Diameter of clearance hole in the fixture - Pre-Installation	d_f	[mm]	7	9	12	14	
Diameter of clearance hole in the fixture - Through Fastening	d_f	[mm]	9	12	14	18	
Depth of drill hole	h_1	[mm]	60	75	90	105	
Installation torque	Screw DIN 933	T_{inst}	[Nm]	10	30	30	55
	Countersunk screw	T_{inst}	[Nm]	10	25	40	50
	Threaded rod	T_{inst}	[Nm]	8	25	30	45
Width across nut	Screw DIN 933 SW	[mm]	10	13	17	19	
Internal hexagon size	Countersunk screw SW	[mm]	-	-	6	8	
Torx® size	Countersunk screw		T30	T45	-	-	
Min. thickness of fixture	Screw DIN 933 or Threaded rod	$t_{fix} \geq$	[mm]	1 / 5 ¹⁾	1 / 7 ¹⁾	1 / 8 ¹⁾	1 / 9 ¹⁾
Min. thickness of fixture	Countersunk screw	$t_{fix} \geq$	[mm]	5 / 9 ¹⁾	7 / 12 ¹⁾	8 / 14 ¹⁾	9 / 16 ¹⁾

¹⁾ Pre-Installation / Through Installation. For anchor designing, an easy to operate CD-ROM is available on request or can be downloaded at www.mkt.de.

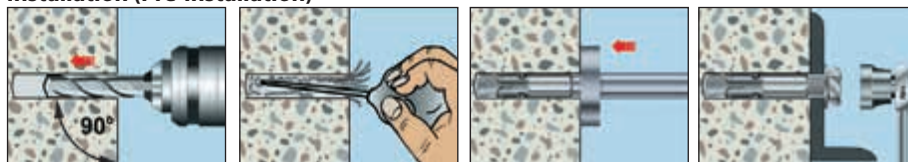
Pre-installation:



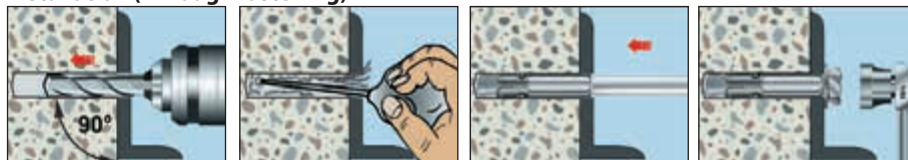
Through fastening:



Installation (Pre-installation)



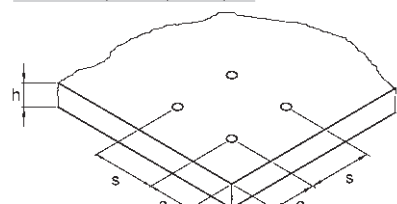
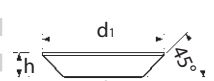
Installation (Through fastening)



Dimension countersunk washer [mm]

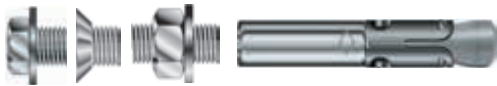
	d1	d2	h
SK M 6	16,5	9,5	3,9
SK M 8	20,5	11,5	5,0
SK M 10	24,5	14,5	5,7
SK M 12	29,5	17,5	6,7

Countersunk head



Wedge Anchor BZ-IG A4

Stainless Steel A4/316



Description

The fastening system BZ-IG A4 is the first approved (ETA-02/0002) wedge anchor for cracked concrete with internal thread. It combines the benefits of a mechanical anchor with an easy installation and the flexibility of an internal thread. For the first time it is possible to fasten balcony and stair railings or stadium seats using a countersunk head screw at favourable costs. Since this anchor system is also approved for use with hexagon head screws and standard threaded rods a wide range of applications is possible. Compared to a drop in anchor the fastening system BZ-IG A4 can carry significant higher loads, even in cracked concrete. The versatility of the MKT Fastening System BZ-IG breaks new ground in design and application.

Applications

Medium to heavy duty fastenings in cracked and non-cracked concrete: Railings, chairs in sports arenas, facade substructures, suspended ceilings, ladders, doors, sprinkler systems, pipe hangers and all kinds of temporary fastenings.

Range of Loading: 2,0 kN - 18,5 kN

Range of concrete quality: C20/25 - C50/60

Pre-Installation

Wedge Anchor BZ-IG A4¹⁾



→ Stainless steel A4/316; Pre-Installation

→ Approved for cracked and non-cracked concrete

Description	Ref. No.	Drill Hole Øxdepth	Anchor- length	Thread Ø x length	Weight per pkg.	pkg. content
		mm	mm	mm	kg	pcs.
BZ-IG M 6-0 A4	03600501	8 x 60	50	M6x20	1,42	100
BZ-IG M 8-0 A4	03610501	10 x 75	62	M8x22	1,31	50
BZ-IG M 10-0 A4	03620501	12 x 90	70	M10x23	1,08	25
BZ-IG M 12-0 A4	03630501	16 x 105	86	M12x27	2,03	20

Coated Screw DIN 933 with Washer DIN EN ISO 7089 (DIN 125)¹⁾

Description	Ref. No.	Fixture- thickn. t _{fix} mm	Wght. per pkg. kg	Pkg. content pcs.
S-IG 6x25 A4	54010501	4-12	0,80	100
S-IG 8x25 A4	54110501	2-8	0,79	50
S-IG 10x40 A4	54210501	15-19	0,90	25
S-IG 12x45 A4	54310501	16-21	1,13	20

Setting Tool BZ-IG for Pre-Installation

Description	Ref. No.	Wght. per pkg. kg
BZ-IGS M 6V	43005150	0,43
BZ-IGS M 8V	43100150	0,44
BZ-IGS M 10V	43200150	0,46
BZ-IGS M 12V	43300150	0,56

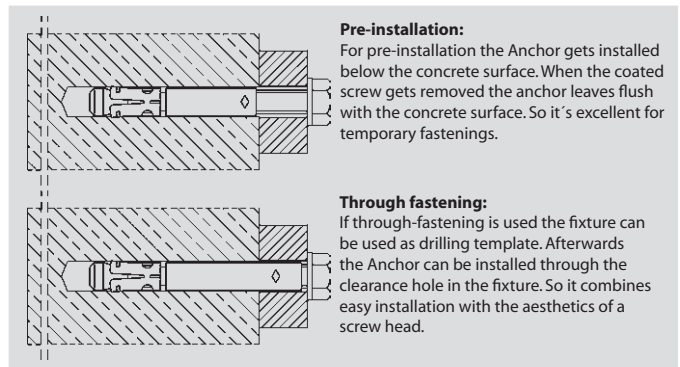
Coated Countersunk Screw DIN 7991 with Countersunk Washer¹⁾

Description	Ref. No.	Fixture- thickn. t _{fix} mm	Wght. per pkg. kg	Pkg. content pcs.
SK-IG 6x25 A4	55013501	6-14	0,53	100
SK-IG 8x30 A4	55112501	9-15	0,59	50
SK-IG 10x30 A4	55211501	8-11	0,48	25
SK-IG 12x35 A4	55311501	9-14	0,64	20

Coated Hex Nut DIN 933 with Washer DIN EN ISO 7089 (DIN 125)¹⁾

Description	Ref. No.	Wght. per pkg. kg	Pkg. content pcs
MU-IG 6 A4	56005501	0,32	100
MU-IG 8 A4	56105501	0,35	50
MU-IG 10 A4	56205501	0,36	25
MU-IG 12 A4	56305501	0,45	20

¹⁾ Screws or hex nuts and washers to be ordered separately.
Anchor system in high corrosion resistant steel grade 1.4529 on demand.
Other screw lengths according to DIN 933 on demand.



Through Fastening

Wedge Anchor BZ-IG A4¹⁾



→ Stainless steel A4/316; Through Fastening

→ Approved for cracked and non-cracked concrete

Description	Ref. No.	Drill Hole Øxdepth	Fixture- thickness t _{fix} mm	Anchor- length l mm	Thread Ø x length mm	Weight per pkg. kg	pkg. content pcs	
		mm	Typ S-IG	Typ SK-IG				
BZ-IG M 6-10 A4	03602501	8 x 60	10	14	60	M6 x 20	1,80	100
BZ-IG M 6-20 A4	03604501	8 x 60	20	24	70	M6 x 20	2,20	100
BZ-IG M 6-30 A4	03606501	8 x 60	30	34	80	M6 x 20	2,60	100
BZ-IG M 8-10 A4	03611501	10 x 75	10	15	72	M8 x 22	1,65	50
BZ-IG M 8-20 A4	03612501	10 x 75	20	25	82	M8 x 22	1,95	50
BZ-IG M 8-30 A4	03613501	10 x 75	30	35	92	M8 x 22	2,25	50
BZ-IG M 10-10 A4	03621501	12 x 90	10	16	80	M10 x 23	1,32	25
BZ-IG M 10-20 A4	03622501	12 x 90	20	26	90	M10 x 23	1,48	25
BZ-IG M 10-30 A4	03623501	12 x 90	30	36	100	M10 x 23	1,76	25
BZ-IG M 12-10 A4	03631501	16 x 105	10	17	96	M12 x 27	2,34	20
BZ-IG M 12-20 A4	03632501	16 x 105	20	27	106	M12 x 27	2,66	20
BZ-IG M 12-30 A4	03633501	16 x 105	30	37	116	M12 x 27	2,97	20

Setting Tool BZ-IG for Through Fastening

Description	Ref. No.	Weight per package kg
BZ-IGS M 6D	43005155	0,32
BZ-IGS M 8D	43100155	0,33
BZ-IGS M 10D	43200155	0,33
BZ-IGS M 12D	43300155	0,35

Coated Screw DIN 933 with Washer DIN EN ISO 7089 (DIN 125)¹⁾

Description	Ref. No.	Wght. per pkg. kg	Pkg. content pcs
S-IG 6x16 A4	54020501	0,64	100
S-IG 8x18 A4	54120501	0,68	50
S-IG 10x20 A4	54220501	0,64	25
S-IG 12x25 A4	54320501	0,67	20

Coated Countersunk Screw DIN 7991 with Countersunk Washer¹⁾

Description	Ref. No.	Wght. per pkg. kg	Pkg. content pcs
SK-IG 6x16 A4	55010501	0,64	100
SK-IG 8x20 A4	55110501	0,60	50
SK-IG 10x25 A4	55210501	0,62	25
SK-IG 12x30 A4	55310501	0,80	20

¹⁾ Screws to be ordered separately.
Anchor system in high corrosion resistant steel grade 1.4529 on demand.



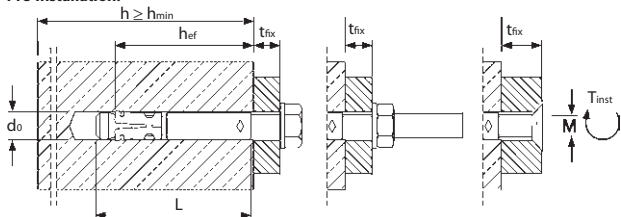
Extract from Permissible Service Conditions of ETA-02/0002

Approved loads for single anchor without influence of spacing and edge distance.
Total safety factor as per ETAG 001 included (γ_M und γ_P).

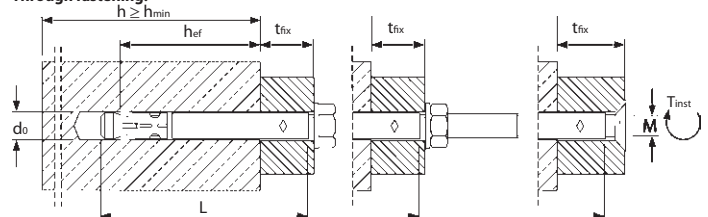
Loads and performance data	Wedge Anchor BZ-IG A4		M 6	M 8	M 10	M 12
	C25/30 Num	[kN]				
cracked concrete						
Mean ultimate loads, tension	C25/30 Num	[kN]	14,1	19,8	28,3	45,9
Mean ultimate loads, shear	C25/30 V _{um}	[kN]	12,0	12,2	14,9	45,4
Approved loads, tension	C20/25 appr.N	[kN]	2,0	3,6	4,8	7,9
	C25/30 appr.N	[kN]	2,2	3,9	5,2	8,7
	C30/37 appr.N	[kN]	2,4	4,4	5,8	9,7
	C40/50 appr.N	[kN]	2,8	5,0	6,7	11,2
	C50/60 appr.N	[kN]	3,1	5,5	7,4	12,3
non-cracked concrete						
Approved loads, tension	C20/25 appr.N	[kN]	4,8	6,3	7,9	11,9
	C25/30 appr.N	[kN]	5,2	7,0	8,7	13,1
	C30/37 appr.N	[kN]	5,4	7,7	9,7	14,5
	C40/50 appr.N	[kN]	5,4	9,0	11,2	16,8
	C50/60 appr.N	[kN]	5,4	9,8	12,3	18,5
cracked and non-cracked concrete						
Approved loads, shear (Pre-Installation)	≥ C20/25 appr.V	[kN]	3,3	5,3	6,1	13,5
Approved loads, shear (Through Fastening)	≥ C20/25 appr.V	[kN]	4,2	4,3	5,5	16,9
Approved bending moments (Pre-Installation)	appr.M	[Nm]	4,9	12,0	23,9	41,9
Approved bending moments (Through Fastening)	appr.M	[Nm]	16,1	25,3	39,9	109,3
Spacing and edge distance						
Effective anchorage depth	h_{ef}	[mm]	45	58	65	80
Characteristic spacing	$s_{cr,N}$	[mm]	135	174	195	240
Characteristic edge distance	$c_{cr,N}$	[mm]	67,5	87	97,5	120
cracked concrete						
Minimum spacing / for edge distance c	s_{min} / c	[mm]	50 / 60	60 / 80	70 / 100	80 / 120
Minimum edge distance / for spacing s	c_{min} / s	[mm]	50 / 75	60 / 100	70 / 100	80 / 120
non-cracked concrete						
Minimum spacing / for edge distance c	s_{min} / c	[mm]	50 / 80	60 / 100	65 / 120	80 / 160
Minimum edge distance / for spacing s	c_{min} / s	[mm]	50 / 115	60 / 155	70 / 170	100 / 210
Minimum thickness of concrete slab	h_{min}	[mm]	100	120	130	160
Installation parameters						
Drill hole diameter	d_o	[mm]	8	10	12	16
Diameter of clearance hole in the fixture - Pre-Installation	d_r	[mm]	7	9	12	14
Diameter of clearance hole in the fixture - Through Fastening	d_r	[mm]	9	12	14	18
Depth of drill hole	h_1	[mm]	60	75	90	105
Installation torque	Screw DIN 933 T_{inst}	[Nm]	15	40	50	100
	Countersunk screw T_{inst}	[Nm]	12	25	45	60
	Threaded rod T_{inst}	[Nm]	8	25	40	80
Width across nut	Screw DIN 933 SW	[mm]	10	13	17	19
Internal hexagon size	Countersunk screw SW	[mm]	-	-	6	8
Torx® size	Countersunk screw		T30	T40	-	-
Min. thickness of fixture	Screw DIN 933 or Threaded rod $t_{fix} \geq$	[mm]	1 / 5 ¹⁾	1 / 7 ¹⁾	1 / 8 ¹⁾	1 / 9 ¹⁾
Min. thickness of fixture	Countersunk screw $t_{fix} \geq$	[mm]	5 / 9 ¹⁾	7 / 12 ¹⁾	8 / 14 ¹⁾	9 / 16 ¹⁾

¹⁾ Pre-Installation / Through Installation. For anchor designing, an easy to operate CD-ROM is available on request or can be downloaded at www.mkt.de.

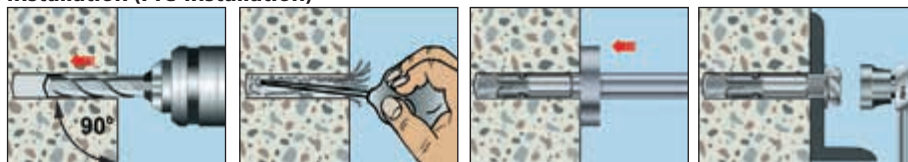
Pre-installation:



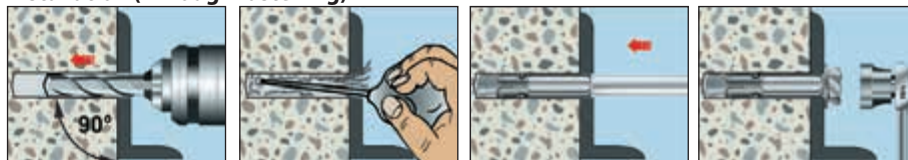
Through fastening:



Installation (Pre-installation)

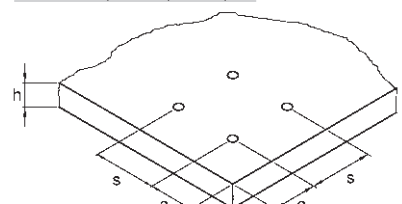
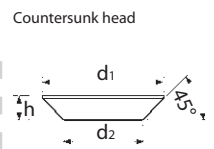


Installation (Through fastening)



Dimension countersunk washer [mm]

	d1	d2	h
SK M 6	16,5	9,5	3,9
SK M 8	20,5	11,5	5,0
SK M 10	24,5	14,5	5,7
SK M 12	29,5	17,5	6,7



Mechanical Heavy Duty Anchors

Wedge Anchor B

Steel, zinc plated



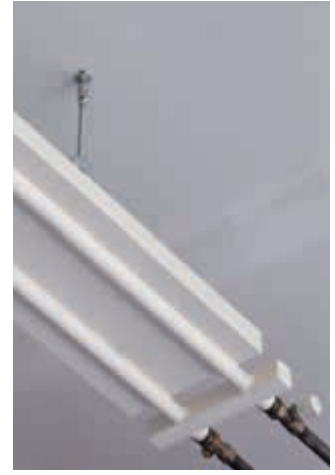
Description

The Wedge Anchor B (ETA, Option 7) is a highly efficient throughbolt with excellent load bearing capacity in non-cracked concrete and close anchor spacing and edge distances. A broad range of more than 150 types, sizes and lengths make it a universal use anchor for medium to heavy duty applications. The ETA for Wedge Anchor B with stainless steel expansion clip has been expanded to include reduced embedment depths in all diameters.

Long Wedge Anchor B-U with large washer see page 24.

Applications

Suspended ceilings (M6-M10), metal constructions, channels, brackets, supports, hand rails, cable trays, ducts, shelf feet.



Range of loading: **2,9 kN - 37,2 kN**

Range of concrete quality: **C20/25 - C50/60**



Wedge Anchor B



→ Steel zinc plated

→ Approved for non-cracked concrete

Description	Ref. No.	Drill hole Ø mm	Drill hole depth mm		Setting-depth mm	Fixture thickness t _{fix} mm		Anchor-length mm	Thread	Packg. content pcs.	Weight per pkg. kg	
			h ₁	h _{1,red} ²⁾		h _{nom}	h _{nom,red} ²⁾					t _{fix}
B 6-5/40 ¹⁾	01005101	6	-	35	-	27	-	5	40	M6x16	100	1,05
B 6-5/52	01006101	6	-	45	-	39	-	5	52	M6x20	100	1,26
B 6-10-20/67	01010101	6	55	45	49	39	10	20	67	M6x30	100	1,55
B 6-15-25/72	01013101	6	55	45	49	39	15	25	72	M6x35	100	1,63
B 6-25-35/82	01015101	6	55	45	49	39	25	35	82	M6x35	100	1,81
B 6-30-40/87	01020101	6	55	45	49	39	30	40	87	M6x35	100	1,91
B 6-40-50/97	01025101	6	55	45	49	39	40	50	97	M6x35	100	2,07
B 8-5/50 ¹⁾	01105101	8	-	45	-	35	-	5	50	M8x22	100	2,32
B 8-4/60	01110101	8	-	55	-	47	-	4	60	M8x25	100	2,62
B 8-10-19/75	01115101	8	65	55	56	47	10	19	75	M8x40	100	3,10
B 8-15-24/80	01120101	8	65	55	56	47	15	24	80	M8x45	100	3,26
B 8-20-29/85	01125101	8	65	55	56	47	20	29	85	M8x50	100	3,40
B 8-25-34/90	01130101	8	65	55	56	47	25	34	90	M8x55	100	3,59
B 8-30-39/95	01135101	8	65	55	56	47	30	39	95	M8x60	100	3,72
B 8-35-44/100	01140101	8	65	55	56	47	35	44	100	M8x65	100	3,89
B 8-45-54/110	01145101	8	65	55	56	47	45	54	110	M8x75	100	4,22
B 8-55-64/120	01150101	8	65	55	56	47	55	64	120	M8x85	100	4,54
B 8-100-109/165	01158101	8	65	55	56	47	100	109	165	M8x85	50	2,99
B 10-10/60 ¹⁾	01205101	10	-	50	-	40	-	10	60	M10x25	50	2,29
B 10-10-16/85	01210101	10	70	65	62	56	10	16	85	M10x40	50	2,83
B 10-15-21/90	01215101	10	70	65	62	56	15	21	90	M10x45	50	2,94
B 10-20-26/95	01220101	10	70	65	62	56	20	26	95	M10x50	50	3,06
B 10-30-36/105	01225101	10	70	65	62	56	30	36	105	M10x60	50	3,32
B 10-45-51/120	01230101	10	70	65	62	56	45	51	120	M10x75	50	3,72
B 10-50-56/125	01235101	10	70	65	62	56	50	56	125	M10x80	50	3,85
B 10-70-76/145	01240101	10	70	65	62	56	70	76	145	M10x80	50	4,35
B 10-100-106/175	01245101	10	70	65	62	56	100	106	175	M10x80	50	5,10
B 10-140-146/215	01250101	10	70	65	62	56	140	146	215	M10x80	25	3,06

¹⁾ Not part of approval, expansion clip steel, zinc plated.

²⁾ Reduced anchorage depth (observe reduced loads).

Wedge Anchor B-U see page 24.

Description	Ref. No.	Drill hole Ø mm	Drill hole depth mm		Setting-depth mm	Fixture thickness t _{fix} mm		Anchor-length mm	Thread	Packg. content pcs.	Weight per pkg. kg	
			h ₁	h _{1,red} ²⁾		h _{nom}	h _{nom,red} ²⁾					t _{fix}
B 12-5/75 ¹⁾	01305101	12	-	65	-	55	-	5	75	M12x30	25	1,98
B 12-13/95	01310101	12	-	75	-	67	-	13	95	M12x50	25	2,33
B 12-10-25/105	01312101	12	90	75	82	67	10	25	105	M12x60	25	2,55
B 12-15-30/110	01315101	12	90	75	82	67	15	30	110	M12x65	25	2,60
B 12-20-35/115	01320101	12	90	75	82	67	20	35	115	M12x70	25	2,70
B 12-30-45/125	01325101	12	90	75	82	67	30	45	125	M12x80	25	2,88
B 12-50-65/145	01330101	12	90	75	82	67	50	65	145	M12x100	25	3,26
B 12-65-80/160	01335101	12	90	75	82	67	65	80	160	M12x100	25	3,49
B 12-85-100/180	01340101	12	90	75	82	67	85	100	180	M12x100	25	3,90
B 12-105-120/200	01345101	12	90	75	82	67	105	120	200	M12x100	25	4,22
B 12-125-140/220	01350101	12	90	75	82	67	125	140	220	M12x80	25	5,04
B 12-145-160/240	01355101	12	90	75	82	67	145	160	240	M12x80	20	4,38
B 12-160-175/255	01365101	12	90	75	82	67	160	175	255	M12x80	20	4,68
B 12-190-205/285	01370101	12	90	75	82	67	190	205	285	M12x80	20	5,21
B 12-230-245/325	01375101	12	90	75	82	67	230	245	325	M12x80	20	5,90
B 12-260-275/355	01380101	12	90	75	82	67	260	275	355	M12x80	20	6,53
B 16-5/90 ¹⁾	01505101	16	-	75	-	65	-	5	90	M16x35	20	3,32
B 16-13/115	01510101	16	-	95	-	84	-	13	115	M16x60	20	3,98
B 16-10-28/130	01512101	16	110	95	102	84	10	28	130	M16x70	20	4,50
B 16-30-48/150	01515101	16	110	95	102	84	30	48	150	M16x90	20	4,87
B 16-60-78/180	01520101	16	110	95	102	84	60	78	180	M16x110	20	5,66
B 16-80-98/200	01525101	16	110	95	102	84	80	98	200	M16x110	20	3,12
B 16-100-118/220	01530101	16	110	95	102	84	100	118	220	M16x80	10	3,64
B 16-130-148/250	01535101	16	110	95	102	84	130	148	250	M16x80	10	4,10
B 16-165-183/285	01540101	16	110	95	102	84	165	183	285	M16x80	10	4,68
B 16-200-218/320	01545101	16	110	95	102	84	200	218	320	M16x80	10	5,23
B 20-10/120 ¹⁾	01604101	20	-	100	-	90	-	10	120	M20x50	10	3,17
B 20-5-27/150	01605101	20	130	110	121	99	5	27	150	M20x70	10	3,78
B 20-20-42/165	01607101	20	130	110	121	99	20	42	165	M20x70	10	4,12
B 20-35-57/180	01610101	20	130	110	121	99	35	57	180	M20x70	10	4,44
B 20-60-82/205	01612101	20	130	110	121	99	60	82	205	M20x70	10	4,94
B 20-95-117/240	01615101	20	130	110	121	99	95	117	240	M20x70	10	6,10
B 20-120-142/265	01622101	20	130	110	121	99	120	142	265	M20x70	10	6,65

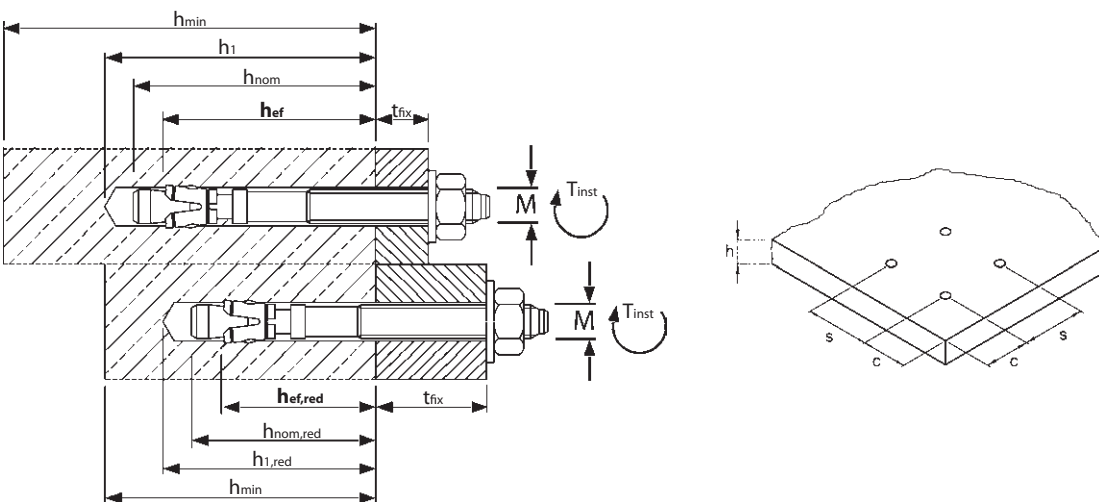


Extract from Permissible Service Condition of ETA-01/0013.

Approved loads for single anchor without influence of spacing and edge distance.
Total safety factor as per ETAG 001 included (γ_M and γ_P).

Loads and performance data		Wedge Anchor B		M 6		M 8		M 10		M 12		M 16		M 20	
Effective anchorage depth	h_{ef}	[mm]	40	-	44	-	48	-	65	-	82	-	100	-	
Reduced anchorage depth	$h_{ef,red}$	[mm]	-	30 ¹⁾	-	35 ¹⁾	-	42	-	50	-	64	-	78	
non-cracked concrete															
Mean ultimate loads, tension	C25/30 N_{um}	[kN]	12	9,6	18,7	12,3	23,6	19,2	34,5	26,1	51,4	43,6	70,0	53,6	
Mean ultimate loads, shear	C25/30 V_{um}	[kN]	7,3	7,3	19,3	19,3	28,1	28,1	41,3	41,3	73,0	73,0	103,6	103,6	
non-cracked concrete															
Approved loads, tension	C20/25 appr. N	[kN]	4,1	2,9	5,7	5,0	7,6	6,5	12,6	8,5	17,8	12,3	24,0	16,5	
	C25/30 appr. N	[kN]	4,1	3,1	6,3	5,5	8,4	7,2	13,8	9,3	19,6	13,5	26,4	18,2	
	C30/37 appr. N	[kN]	4,1	3,5	7,0	6,1	9,3	8,0	15,3	10,4	21,7	15,0	29,3	20,2	
	C40/50 appr. N	[kN]	4,1	4,0	7,3	7,0	10,7	9,2	16,7	12,0	25,1	17,3	33,8	23,3	
	C50/60 appr. N	[kN]	4,1	4,1	7,3	7,3	11,8	10,1	16,7	13,2	27,6	19,0	37,2	25,6	
Approved loads, shear	C20/25 appr. V	[kN]	2,9	2,9	6,3	5,0	8,0	6,5	14,3	8,5	23,6	23,6	37,1	33,1	
	\geq C25/30 appr. V	[kN]	2,9	2,9	6,3	5,5	8,8	7,2	14,3	9,3	23,6	23,6	37,1	36,4	
Approved bending moments	appr. M	[Nm]	5,1	5,1	13,1	13,1	25,7	25,7	44,6	44,6	99,9	99,9	195,0	195,0	
Spacing and edge distance															
Effective anchorage depth	h_{ef}	[mm]	40	30 ¹⁾	44	35 ¹⁾	48	42	65	50	82	64	100	78	
Characteristic spacing	$s_{cr,N}$	[mm]	120	90	132	105	144	126	195	150	246	192	300	234	
Characteristic edge distance	$c_{cr,N}$	[mm]	60	45	66	52,5	72	63	97,5	75	123	96	150	117	
non-cracked concrete															
Minimum spacing	s_{min}	[mm]	35	35	40	40	55	55	75	100	90	100	105	140	
Minimum edge distance	c_{min}	[mm]	40	40	45	45	65	65	90	100	105	100	125	140	
Minimum thickness of concrete slab	h_{min}	[mm]	100	80	100	80	100	100	130	100	170	130	200	160	
Installation parameters															
Drill hole diameter	d_o	[mm]	6	6	8	8	10	10	12	12	16	16	20	20	
Diameter of clearance hole in the fixture	d_f	[mm]	7	7	9	9	12	12	14	14	18	18	22	22	
Depth of drill hole	h_1	[mm]	55	45	65	55	70	65	90	75	110	95	130	110	
Installation torque	T_{inst}	[Nm]	8	8	15	15	30	30	50	50	100	100	200	200	
Width across nut	SW	[mm]	10	10	13	13	17	17	19	19	24	24	30	30	

¹⁾ Application limited to statically indetermined systems.
For anchor designing, an easy to operate CD-ROM is available on request or can be downloaded at www.mkt.de.



Installation



Wedge Anchor B A4 / B HCR

Stainless steel A4/316 and Stainless steel 1.4529



Description

The Wedge Anchor B A4 (ETA, Option 7) is the stainless steel version of Wedge Anchor B. It offers excellent load bearing capacities, close anchor spacing and edge distances. The ETA for Wedge Anchor B with stainless steel expansion clip has been expanded to include reduced embedment depths in all diameters.

Applications

Indoor and outdoor medium to heavy duty applications: Suspended ceilings (M6-M10), metal constructions, channels, brackets, supports, cladding systems, hand rails, cable trays, ducts.

Range of loading: 2,9 kN - 43,9 kN

Range of concrete quality: C20/25 - C50/60



Wedge Anchor B A4



- Stainless steel A4/316
- ETA approval for cracked and non-cracked concrete

Description	Ref. No.	Drill hole Ø mm	Drill hole depth mm		Setting depth mm		Fixture thickness mm		Anchor length mm	Thread mm	Packg. content pcs.	Weight per pkg. kg
			h ₁	h _{1,red} ⁽²⁾	h _{nom}	h _{nom,red} ⁽²⁾	t _{fix}	t _{fix,red} ⁽²⁾				
B 6-5/40 A4 ¹⁾	01005501	6	-	35	-	27	-	5	40	M6x16	100	1,06
B 6-5/52 A4	01006501	6	-	45	-	39	-	5	52	M6x20	100	1,27
B 6-10-20/67 A4	01010501	6	55	45	49	39	10	20	67	M6x30	100	1,56
B 6-25-35/82 A4	01015501	6	55	45	49	39	25	35	82	M6x35	100	1,80
B 6-40-50/97 A4	01025501	6	55	45	49	39	40	50	97	M6x35	100	2,08
B 8-5/50 A4 ¹⁾	01105501	8	-	45	-	35	-	5	50	M8x22	100	2,34
B 8-4/60 A4	01110501	8	-	55	-	47	-	4	60	M8x25	100	2,64
B 8-10-19/75 A4	01115501	8	65	55	56	47	10	19	75	M8x40	100	3,10
B 8-15-24/80 A4	01120501	8	65	55	56	47	15	24	80	M8x45	100	3,28
B 8-20-29/85 A4	01125501	8	65	55	56	47	20	29	85	M8x50	100	3,42
B 8-30-39/95 A4	01135501	8	65	55	56	47	30	39	95	M8x60	100	3,73
B 8-45-54/110 A4	01145501	8	65	55	56	47	45	54	110	M8x75	100	4,20
B 8-55-64/120 A4	01150501	8	65	55	56	47	55	64	120	M8x85	100	4,57
B 10-10/60 A4 ¹⁾	01205501	10	-	50	-	40	-	10	60	M10x25	50	2,30
B 10-10-16/85 A4	01210501	10	70	65	62	56	10	16	85	M10x40	50	2,85
B 10-15-21/90 A4	01215501	10	70	65	62	56	15	21	90	M10x45	50	2,97
B 10-20-26/95 A4	01220501	10	70	65	62	56	20	26	95	M10x50	50	3,10
B 10-30-36/105 A4	01225501	10	70	65	62	56	30	36	105	M10x60	50	3,33
B 10-45-51/120 A4	01230501	10	70	65	62	56	45	51	120	M10x75	50	3,75
B 10-50-56/125 A4	01235501	10	70	65	62	56	50	56	125	M10x80	50	3,87
B 10-70-76/145 A4	01240501	10	70	65	62	56	70	76	145	M10x80	50	4,38
B 10-100-106/175 A4	01245501	10	70	65	62	56	100	106	175	M10x80	50	5,15
B 10-140-146/215 A4	01250501	10	70	65	62	56	140	146	215	M10x80	25	3,10
B 12-5/75 A4 ¹⁾	01305501	12	-	65	-	55	-	5	75	M12x30	25	1,96
B 12-14/95 A4	01310501	12	-	75	-	66	-	14	95	M12x50	25	2,33
B 12-10-25/105 A4	01312501	12	90	75	81	66	10	25	105	M12x60	25	2,53
B 12-15-30/110 A4	01315501	12	90	75	81	66	15	30	110	M12x65	25	2,62
B 12-20-35/115 A4	01320501	12	90	75	81	66	20	35	115	M12x70	25	2,70
B 12-30-45/125 A4	01325501	12	90	75	81	66	30	45	125	M12x80	25	2,88
B 12-50-65/145 A4	01330501	12	90	75	81	66	50	65	145	M12x100	25	3,28
B 12-65-80/160 A4	01335501	12	90	75	81	66	65	80	160	M12x100	25	3,55
B 12-85-100/180 A4	01340501	12	90	75	81	66	85	100	180	M12x100	25	3,90
B 12-105-120/200 A4	01345501	12	90	75	81	66	105	120	200	M12x100	25	4,28
B 12-125-140/220 A4	01350501	12	90	75	81	66	125	140	220	M12x80	25	5,11
B 12-145-160/240 A4	01355501	12	90	75	81	66	145	160	240	M12x80	20	4,39

Description	Ref. No.	Drill hole Ø mm	Drill hole depth mm		Setting depth mm		Fixture thickness mm		Anchor length mm	Thread mm	Packg. content pcs.	Wght. per pkg. kg
			h ₁	h _{1,red} ⁽²⁾	h _{nom}	h _{nom,red} ⁽²⁾	t _{fix}	t _{fix,red} ⁽²⁾				
B 16-5/90 A4 ¹⁾	01505501	16	-	75	-	65	-	5	90	M16x35	20	3,37
B 16-14/115 A4	01510501	16	-	95	-	83	-	14	115	M16x60	20	3,98
B 16-10-26/130 A4	01512501	16	110	95	99	83	10	26	130	M16x70	20	4,34
B 16-30-46/150 A4	01515501	16	110	95	99	83	30	46	150	M16x90	20	4,87
B 16-60-76/180 A4	01520501	16	110	95	99	83	60	76	180	M16x110	20	5,66
B 16-80-96/200 A4	01525501	16	110	95	99	83	80	96	200	M16x110	10	3,26
B 16-100-116/220 A4	01530501	16	110	95	99	83	100	116	220	M16x80	10	3,59
B 16-130-146/250 A4	01535501	16	110	95	99	83	130	146	250	M16x80	10	3,99
B 16-200-216/320 A4	01545501	16	110	95	99	83	200	216	320	M16x80	10	5,16
B 20-5-27/150 A4	01605501	20	130	110	121	99	5	27	150	M20x70	10	3,86
B 20-35-57/180 A4	01610501	20	130	110	121	99	35	57	180	M20x70	10	4,47
B 20-60-82/205 A4	01612501	20	130	110	121	99	60	82	205	M20x70	10	5,03
B 20-95-117/240 A4	01615501	20	130	110	121	99	95	117	240	M20x70	10	6,26

- ¹⁾ Not part of approval.
- ²⁾ Reduced anchorage depth (observe reduced loads).

Wedge Anchor B HCR



- High corrosion resistant steel 1.4529 (HCR)
- Approved for suspended ceilings

Description	Ref. No.	Drill hole Ø mm	Drill hole depth mm		Setting depth mm		Fixture thickness mm		Anchor length mm	Thread mm	Packg. content pcs.	Weight per pkg. kg
			h ₁	h _{1,red} ⁽¹⁾	h _{nom}	h _{nom,red} ⁽¹⁾	t _{fix}	t _{fix,red} ⁽¹⁾				
B 6-0-10/57 HCR	01007651	6	55	45	49	39	0	10	57	M6x20	100	1,58
B 6-10-20/67 HCR	01010651	6	55	45	49	39	10	20	67	M6x20	100	1,78
B 6-25-35/82 HCR	01015651	6	55	45	49	39	25	35	82	M6x20	100	2,13
B 6-40-50/97 HCR	01025651	6	55	45	49	39	40	50	97	M6x20	100	2,35

- ¹⁾ Reduced anchorage depth (observe reduced loads). Other length on demand.



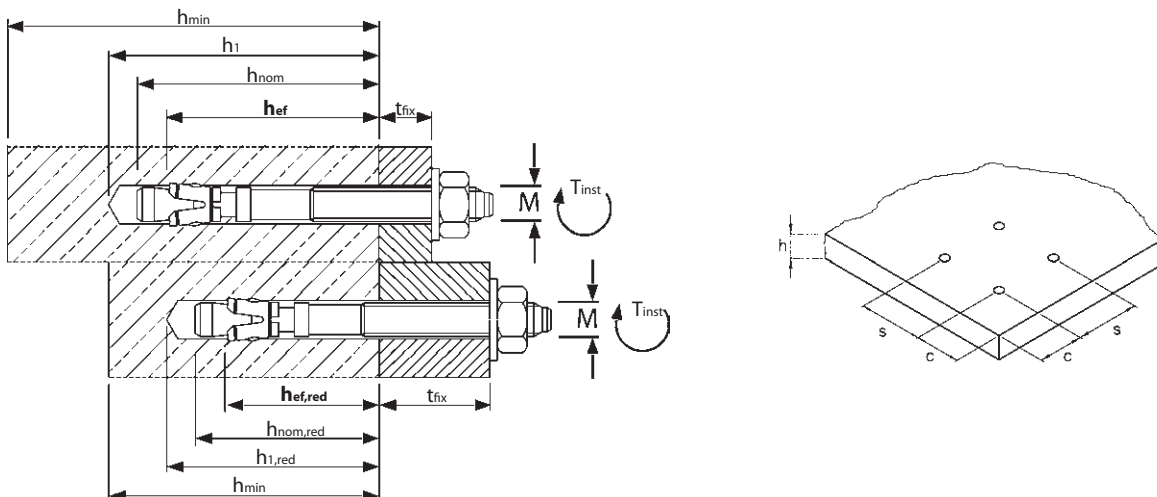
Extract from Permissible Service Conditions of ETA-05/0018 and ETA-06/0155.
 Approved loads for single anchor without influence of spacing and edge distance.
 Total safety factor as per ETAG 001 included (γ_M and γ_p).

Loads and performance data	Wedge Anchor B A4 / HCR	M 6	M 8	M 10	M 12	M 16	M 20
Effective anchorage depth	h_{ef} [mm]	40	44	48	65	80	100
Reduced anchorage depth	$h_{ef,red}$ [mm]	30 ¹⁾	35 ¹⁾	42	50	64	78
non-cracked concrete							
Mean ultimate loads, tension	C25/30 N_{um} [kN]	11,0 10,2	19,6 12,4	23,1 17,5	36,4 22,6	53,5 39,7	73,0 53,1
Mean ultimate loads, shear	C25/30 V_{um} [kN]	9,7 9,7	19,5 19,5	31,9 31,9	42,6 42,6	76,9 76,9	110,4 110,4
cracked concrete (multiple use only)							
Approved loads (any direction)	C20/25 to C50/60 appr. F [kN]	2,4 1,6	- -	- -	- -	- -	- -
non-cracked concrete							
Approved loads, tension	C20/25 appr. N [kN]	3,6 2,9	5,7 4,3	7,6 5,7	11,9 8,5	17,2 12,3	24,0 16,5
	C25/30 appr. N [kN]	3,9 3,1	6,3 4,7	8,4 6,3	13,1 9,3	18,9 13,5	26,4 18,2
	C30/37 appr. N [kN]	4,4 3,5	7,0 5,2	9,3 7,0	14,5 10,4	21,0 15,0	29,3 20,2
	C40/50 appr. N [kN]	4,8 4,0	8,1 6,0	10,7 8,1	16,8 12,0	24,2 17,3	33,8 23,3
	C50/60 appr. N [kN]	4,8 4,4	8,6 6,6	11,8 8,9	18,5 13,2	26,6 19,0	37,2 25,6
Approved loads, shear	C20/25 appr. V [kN]	4,0 3,9	6,9 5,0	8,0 6,5	15,4 8,5	28,6 24,6	43,9 33,1
	\geq C25/30 appr. V [kN]	4,0 4,0	6,9 5,5	8,8 7,2	15,4 9,3	28,6 27,0	43,9 36,4
Approved bending moments	appr. M [Nm]	5,7 5,7	13,7 13,7	28,0 28,0	48,6 48,6	113,7 113,7	231,6 231,6
Spacing and edge distance							
Effective anchorage depth	h_{ef} [mm]	40 30 ¹⁾	44 35 ¹⁾	48 42	65 50	80 64	100 78
Characteristic spacing	$s_{cr,N}$ [mm]	120/370 ²⁾	90/260 ²⁾ 132 105	144 126	195 150	240 192	300 234
Characteristic edge distance	$c_{cr,N}$ [mm]	60/185 ²⁾	45/130 ²⁾ 66 52,5	72 63	97,5 75	120 96	150 117
cracked concrete (multiple use only)							
Minimum spacing	s_{min} [mm]	50 50	- -	- -	- -	- -	- -
Minimum edge distance	c_{min} [mm]	50 50	- -	- -	- -	- -	- -
Minimum thickness of concrete slab	h_{min} [mm]	80 80	- -	- -	- -	- -	- -
non-cracked concrete							
Minimum spacing	s_{min} / c [mm]	35/40 35/40	35/65 60/60	45/70 55/65	60/100 100/100	80/120 110/110	100/150 140/140
Minimum edge distance	c_{min} / s [mm]	35/60 40/35	45/110 60/60	55/80 65/55	70/100 100/100	80/140 110/110	100/180 140/140
Minimum thickness of concrete slab	h_{min} [mm]	100 80	100 80	100 100	130 100	160 130	200 160
Installation parameters							
Drill hole diameter	d_o [mm]	6 6	8 8	10 10	12 12	16 16	20 20
Diameter of clearance hole in the fixture	d_f [mm]	7 7	9 9	12 12	14 14	18 18	22 22
Depth of drill hole	h_1 [mm]	55 45	65 55	70 65	90 75	110 95	130 110
Installation torque	T_{inst} [Nm]	6/8 ²⁾ 6/8 ²⁾	15 15	25 25	50 50	100 100	160 160
Width across nut	SW [mm]	10 10	13 13	17 17	19 19	24 24	30 30

¹⁾ Application limited to statically indetermined systems.

²⁾ For applications according to ETA-05/0018. / For applications according to ETA-06/0155.

For anchor designing, an easy to operate CD-ROM is available on request or can be downloaded at www.mkt.de.



Installation



Wedge Anchor B

Hot dip galvanized



Description

The Wedge Anchor B hot dip galvanized, with ETA-Approval, Option 7, offers better corrosion resistance together with excellent load bearing capacity close anchor spacing and edge distances. All sizes with stainless steel expansion sleeve.

Applications

Indoor medium to heavy duty applications: metal constructions, channels, brackets, supports, cladding systems, hand rails, cable trays, ducts.

Range of loading: 2,9 kN - 37,2 kN

Range of concrete quality: C20/25 - C50/60



Wedge Anchor B fvz



→ Steel, hot dip galvanized ($\geq 40\mu\text{m}$, EN ISO 1461)

→ Better corrosion resistance

Description	Ref. No.	Drill hole \varnothing mm	Drill hole depth mm	Setting depth mm		Fixture thickness t_{fix} mm		Anchor length mm	Thread mm	Packg. content pcs.	Weight per pkg. kg	
				h_1	$h_{1,red}^{2)}$	h_{nom}	$h_{nom,red}^{2)}$					t_{fix}
B 6-5/40 ¹⁾	01005201	6	-	35	-	27	-	5	40	M6x16	100	1,06
B 6-10-20/67 ¹⁾	01010201	6	55	45	49	39	10	20	67	M6x30	100	1,57
B 6-25-35/82 ¹⁾	01015201	6	55	45	49	39	25	35	82	M6x35	100	1,90
B 6-40-50/97 ¹⁾	01025201	6	55	45	49	39	40	50	97	M6x35	100	2,09
B 8-5/50 ¹⁾	01105201	8	-	45	-	35	-	5	50	M8x22	100	2,36
B 8-4/60	01110201	8	-	55	-	47	-	4	60	M8x25	100	2,76
B 8-10-19/75	01115201	8	65	55	56	47	10	19	75	M8x40	100	3,17
B 8-15-24/80	01120201	8	65	55	56	47	15	24	80	M8x45	100	3,36
B 8-20-29/85	01125201	8	65	55	56	47	20	29	85	M8x50	100	3,50
B 8-30-39/95	01135201	8	65	55	56	47	30	39	95	M8x60	100	3,83
B 8-45-54/110	01145201	8	65	55	56	47	45	54	110	M8x75	100	4,29
B 8-55-64/120	01150201	8	65	55	56	47	55	64	120	M8x85	100	4,59
B 10-10/60 ¹⁾	01205201	10	-	50	-	40	-	10	60	M10x25	50	2,32
B 10-10-16/85	01210201	10	70	65	62	56	10	16	85	M10x40	50	2,90
B 10-15-21/90	01215201	10	70	65	62	56	15	21	90	M10x45	50	3,01
B 10-20-26/95	01220201	10	70	65	62	56	20	26	95	M10x50	50	3,15
B 10-30-36/105	01225201	10	70	65	62	56	30	36	105	M10x60	50	3,35
B 10-45-51/120	01230201	10	70	65	62	56	45	51	120	M10x75	50	3,77
B 10-50-56/125	01235201	10	70	65	62	56	50	56	125	M10x80	50	3,93
B 10-70-76/145	01240201	10	70	65	62	56	70	76	145	M10x80	50	4,50
B 10-100-106/175	01245201	10	70	65	62	56	100	106	175	M10x80	50	4,93
B 10-140-146/215	01250201	10	70	65	62	56	140	146	215	M10x80	25	3,10

¹⁾ Not part of approval.

²⁾ Reduced anchorage depth (observe reduced loads).

Description	Ref. No.	Drill hole \varnothing mm	Drill hole depth mm	Setting depth mm		Fixture thickness t_{fix} mm		Anchor length mm	Thread mm	Packg. content pcs.	Weight per pkg. kg	
				h_1	$h_{1,red}^{2)}$	h_{nom}	$h_{nom,red}^{2)}$					t_{fix}
B 12-5/75 ¹⁾	01305201	12	-	65	-	55	-	5	75	M12x30	25	1,99
B 12-13/95	01310201	12	-	75	-	67	-	13	95	M12x50	25	2,38
B 12-15-30/110	01315201	12	90	75	82	67	15	30	110	M12x65	25	2,66
B 12-20-35/115	01320201	12	90	75	82	67	20	35	115	M12x70	25	2,71
B 12-30-45/125	01325201	12	90	75	82	67	30	45	125	M12x80	25	2,92
B 12-50-65/145	01330201	12	90	75	82	67	50	65	145	M12x100	25	3,25
B 12-65-80/160	01335201	12	90	75	82	67	65	80	160	M12x100	25	3,54
B 12-85-100/180	01340201	12	90	75	82	67	85	100	180	M12x100	25	3,85
B 12-105-120/200	01345201	12	90	75	82	67	105	120	200	M12x100	25	4,28
B 16-13/115	01510201	16	-	95	-	84	-	13	115	M16x60	20	3,96
B 16-10-28/130	01512201	16	110	95	102	84	10	28	130	M16x70	20	4,41
B 16-30-48/150	01515201	16	110	95	102	84	30	48	150	M16x90	20	4,92
B 20-5-27/150	01605201	20	130	110	121	99	5	27	150	M20x70	10	3,84
B 20-35-57/180	01610201	20	130	110	121	99	35	57	180	M20x70	10	4,44
B 20-60-82/205	01612201	20	130	110	121	99	60	82	205	M20x70	10	5,00
B 20-95-117/240	01615201	20	130	110	121	99	95	117	240	M20x70	10	6,26

¹⁾ Not part of approval.

²⁾ Reduced anchorage depth (observe reduced loads).



Extract from Permissible Service Conditions of ETA-01/0013

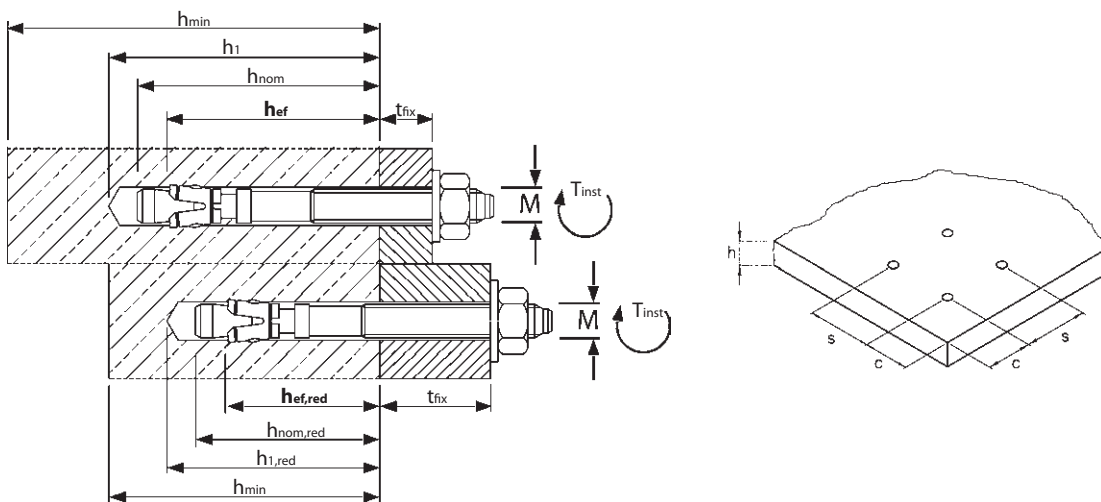
Approved loads for single anchor without influence of spacing and edge distance.
Total safety factor as per ETAG 001 included (γ_M and γ_p).

Loads and performance data	Wedge Anchor B	M 6 ¹⁾	M 8	M 10	M 12	M 16	M 20						
Effective anchorage depth	h_{ef} [mm]	40	44	48	65	82	100						
Reduced anchorage depth	$h_{ef,red}$ [mm]	30 ²⁾	35 ²⁾	42	50	64	78						
non-cracked concrete													
Mean ultimate loads, tension	C25/30 N_{um} [kN]	12 9,6	18,7 12,3	23,6 19,2	34,5 26,1	51,4 43,6	70,0 53,6						
Mean ultimate loads, shear	C25/30 V_{um} [kN]	7,3 7,3	19,3 19,3	28,1 28,1	41,3 41,3	73,0 73,0	103,6 103,6						
non-cracked concrete													
Approved loads, tension	C20/25 appr.N [kN]	4,1 2,9	5,7 5,0	7,6 6,5	12,6 8,5	17,8 12,3	24,0 16,5						
	C25/30 appr.N [kN]	4,1 3,1	6,3 5,5	8,4 7,2	13,8 9,3	19,6 13,5	26,4 18,2						
	C30/37 appr.N [kN]	4,1 3,5	7,0 6,1	9,3 8,0	15,3 10,4	21,7 15,0	29,3 20,2						
	C40/50 appr.N [kN]	4,1 4,0	7,3 7,0	10,7 9,2	16,7 12,0	25,1 17,3	33,8 23,3						
Approved loads, shear	C50/60 appr.N [kN]	4,1 4,1	7,3 7,3	11,8 10,1	16,7 13,2	27,6 19,0	37,2 25,6						
	C20/25 appr.V [kN]	2,9 2,9	6,3 5,0	8,0 6,5	14,3 8,5	23,6 23,6	37,1 33,1						
	\geq C25/30 appr.V [kN]	2,9 2,9	6,3 5,5	8,8 7,2	14,3 9,3	23,6 23,6	37,1 36,4						
Approved bending moments	appr.M [Nm]	5,1 5,1	13,1 13,1	25,7 25,7	44,6 44,6	99,9 99,9	195,0 195,0						
Spacing and edge distance													
Effective anchorage depth	h_{ef} [mm]	40	30	44	35	48	42	65	50	82	64	100	78
Characteristic spacing	$s_{cr,N}$ [mm]	120	90	132	105	144	126	195	150	246	192	300	234
Characteristic edge distance	$c_{cr,N}$ [mm]	60	45	66	52,5	72	63	97,5	75	123	96	150	117
non-cracked concrete													
Minimum spacing	s_{min} [mm]	35	35	40	40	55	55	75	100	90	100	105	140
Minimum edge distance	c_{min} [mm]	40	40	45	45	65	65	90	100	105	100	125	140
Minimum thickness of concrete slab	h_{min} [mm]	100	80	100	80	100	100	130	100	170	130	200	160
Installation parameters													
Drill hole diameter	d_o [mm]	6	6	8	8	10	10	12	12	16	16	20	20
Diameter of clearance hole in the fixture	d_f [mm]	7	7	9	9	12	12	14	14	18	18	22	22
Depth of drill hole	h_1 [mm]	55	45	65	55	70	65	90	75	110	95	130	110
Installation torque	T_{inst} [Nm]	8	8	15	15	30	30	40	40	90	90	120	120
Width across nut	SW [mm]	10	10	13	13	17	17	19	19	24	24	30	30

¹⁾ Not part of approval.

²⁾ Application limited to statically indeterminated systems.

For anchor designing, an easy to operate CD-ROM is available on request or can be downloaded at www.mkt.de.



Installation



Wedge Anchor B-U

Steel, zinc plated



Description

The Wedge Anchor B-U (ETA, Option 7) is especially suitable to fasten wooden structures to concrete. The large washer as per DIN EN ISO 7094 (formerly DIN 440) distributes the pretensioning force on a wider area and reduces the pressing into the wood.

Two anchorage depths for each anchor size provide a variety of medium to heavy duty applications at excellent load bearing capacities, close anchor spacing and edge distances.

Applications

Wooden structures, columns, steel structures, pallet racks.



Range of loading: 8,5 kN - 27,6 kN

Range of concrete quality: C20/25 - C50/60



Wedge Anchor B-U



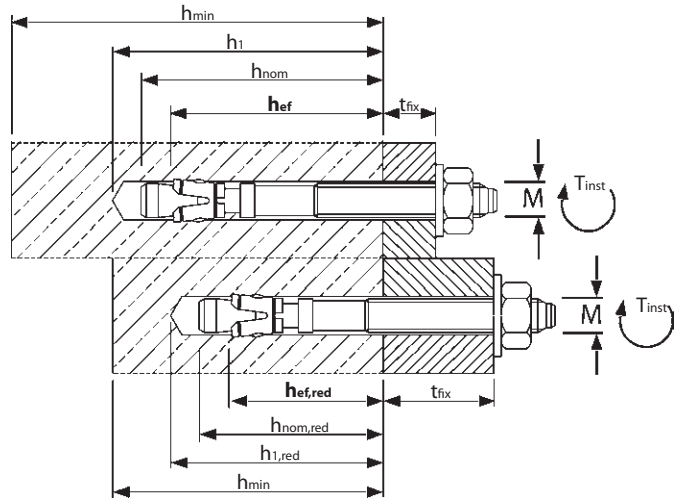
- Steel, zinc plated; Large washer DIN EN ISO 7094 (formerly DIN 440)
- Approved for non-cracked concrete

Description	Ref. No.	Drill hole Ø mm	Drill hole depth mm		Setting depth mm		Fixture thickness t _{fix} mm		Anchor-length mm	Thread	Pkg. content pcs.	Weight per pkg. kg
			h ₁	h _{1,red} ³⁾	h _{nom}	h _{nom,red} ³⁾	t _{fix}	t _{fix,red} ³⁾				
B-U 12-85-100/180 ¹⁾	01340701	12	90	75	82	67	85	100	180	M12x100	25	4,74
B-U 12-105-120/200 ¹⁾	01345701	12	90	75	82	67	105	120	200	M12x100	25	5,05
B-U 12-125-140/220 ¹⁾	01350701	12	90	75	82	67	125	140	220	M12x80	25	5,90
B-U 12-145-160/240 ¹⁾	01355701	12	90	75	82	67	145	160	240	M12x80	20	5,09
B-U 12-160-175/255 ¹⁾	01365701	12	90	75	82	67	160	175	255	M12x80	20	5,36
B-U 12-190-205/285 ¹⁾	01370701	12	90	75	82	67	190	205	285	M12x80	20	5,88
B-U 12-230-245/325 ¹⁾	01375701	12	90	75	82	67	230	245	325	M12x80	20	6,56
B-U 12-260-275/355 ¹⁾	01380701	12	90	75	82	67	260	275	355	M12x80	10	3,48
B-U 12-335-350/430 ¹⁾	01390701	12	90	75	82	67	335	350	430	M12x80	20	8,00
B-U 16-80-98/200 ²⁾	01525701	16	110	95	102	84	80	98	200	M16x110	10	3,75
B-U 16-100-118/220 ²⁾	01530701	16	110	95	102	84	100	118	220	M16x80	10	4,25
B-U 16-130-148/250 ²⁾	01535701	16	110	95	102	84	130	148	250	M16x80	10	4,72
B-U 16-165-183/285 ²⁾	01540701	16	110	95	102	84	165	183	285	M16x80	10	5,32
B-U 16-200-218/320 ²⁾	01545701	16	110	95	102	84	200	218	320	M16x80	10	5,95
B-U 16-220-238/340 ²⁾	01550701	16	110	95	102	84	220	238	340	M16x80	10	6,16
B-U 16-260-278/380 ²⁾	01557701	16	110	95	102	84	260	278	380	M16x80	10	6,75
B-U 16-300-318/420 ²⁾	01560701	16	110	95	102	84	300	318	420	M16x80	10	7,35

¹⁾ Ø washer M12 DIN EN ISO 7094 = 44 mm

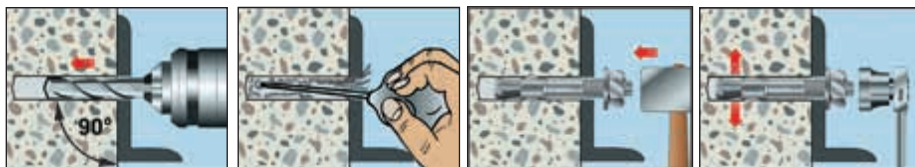
²⁾ Ø washer M16 DIN EN ISO 7094 = 56 mm

³⁾ Reduced anchorage depth (observe reduced loads).



Installation parameters, extract from permissible service condition of ETA-01/0013 see page 19.

Installation



L - Anchor B-W

Steel, zinc plated

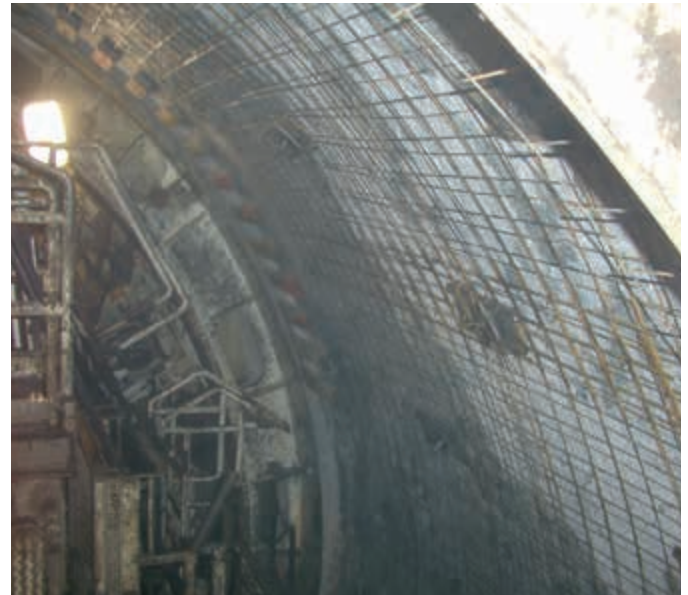


Description

The Wedge Anchor B-W is a self expanding hammer-in anchor, designed to attach steel reinforcing mats to existing concrete. The non threaded end is bent to hold the reinforcement mat in place.

Applications

Safe and fast fastening of reinforcing mats for sprayed concrete.



Mechanical Heavy Duty Anchors

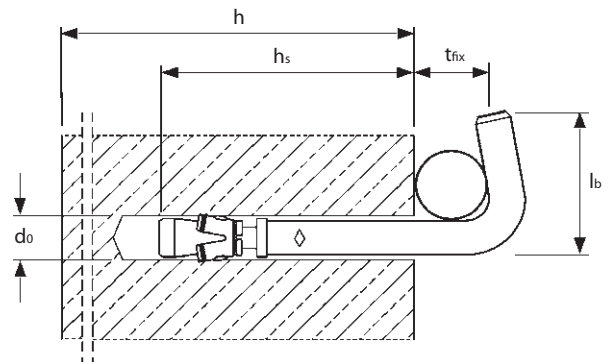
L-Anchor B-W



- Steel, zinc plated
- For attaching steel reinforcing mats

Description	Ref. No.	Setting-depth h_s mm	Fixture-thickness t_{fix} mm	Drill hole \varnothing x depth mm	Bend length l_b mm	Package content pieces	Weight per package kg
B-W 8x80x32	93140101	55	20	8 x 65	32	200	6,45
B-W 8x110x35	93148101	55	50	8 x 65	35	200	8,50
B-W 8x140x35	93163101	55	80	8 x 65	35	200	10,50

Other lengths and stainless steel A4/316 on demand.



Wedge Anchor B-IG

Steel, zinc plated / Stainless steel A4/316



Wedge Anchor B-IG



Wedge Anchor B-IG A4

Description

The Wedge Anchor B-IG is the internally threaded version of the European approved Wedge Anchor B. It can be installed in normal drill holes without a setting tool. Expansion is achieved by tightening the screw. The fixture can easily be removed. Closer anchor spacing and edge distances than with drop-in anchors.

Applications

Medium duty anchorings where the use of an internal thread is required and/or anchor spacing and edge distances are closer than those needed for drop-in anchors: suspended ceilings, fastening of flat steel structures, ducts, ventilation systems, railings.



Range of loading: 2,9 kN - 15,9 kN

Range of concrete quality: C20/25 - C50/60



Wedge Anchor B-IG



→ Steel, zinc plated

→ With internal thread

Description	Ref. No.	Drill hole Øxdepth	Setting- depth ¹⁾	Anchor- length l	Length of screw	Thread	Package content	Weight per pa- ckage kg
		mm	mm	mm	mm	mm	pcs.	kg
B-IG M 6 x 45	03005101	8x60	51	45	t _{ix} +10	M6x15	100	1,39
B-IG M 8 x 50	03105101	10x65	57	50	t _{ix} +12	M8x15	100	2,40
B-IG M 10 x 60	03205101	12x80	71	60	t _{ix} +15	M10x20	50	1,95
B-IG M 12 x 75	03305101	16x95	84	75	t _{ix} +20	M12x26	25	2,29

¹⁾ Install Anchor below concrete surface.

Wedge Anchor B-IG A4



→ Stainless steel A4/316

→ With internal thread

Description	Ref. No.	Drill hole Øxdepth	Setting- depth ¹⁾	Anchor- length l	Length of screw	Thread	Package content	Weight per pa- ckage kg
		mm	mm	mm	mm	mm	pcs.	kg
B-IG M 6 x 45 A4	03005501	8x60	51	45	t _{ix} +10	M6x15	100	1,41
B-IG M 8 x 50 A4	03105501	10x65	57	50	t _{ix} +12	M8x15	100	2,45
B-IG M 10 x 60 A4	03205501	12x75	71	60	t _{ix} +15	M10x20	50	1,98
B-IG M 12 x 75 A4	03305501	16x95	84	75	t _{ix} +20	M12x26	25	2,23

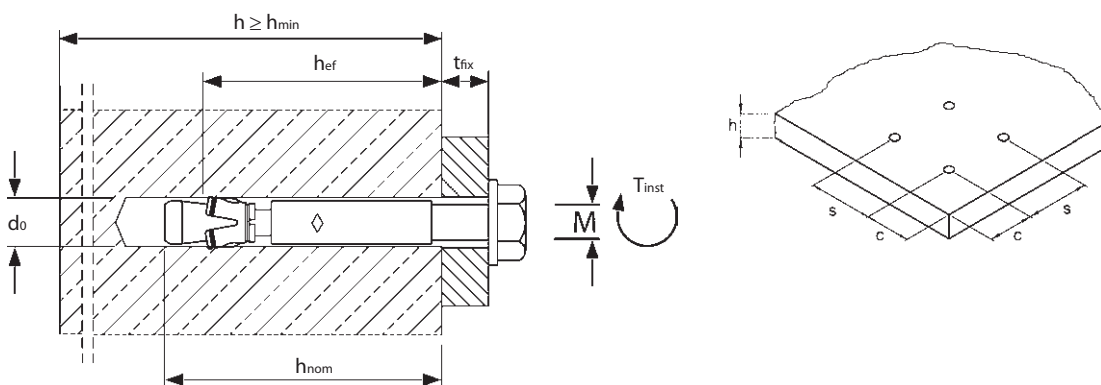
¹⁾ Install Anchor below concrete surface.

Recommended loads for single anchor without influence of spacing and edge distance.
Total safety factor as per ETAG included (γ_M and γ_F)

Loads and performance data	Wedge Anchor B-IG		non-cracked concrete							
			M 6x45		M 8x50		M 10x60		M 12x75	
			steel 5.8	A4-70	steel 5.8	A4-70	steel 5.8	A4-70	steel 5.8	A4-70
Mean ultimate loads, tension	C25/30 N_{um}	[kN]	10,1	14,1	18,3	19,6	24,0	25,3	36,3	37,8
Mean ultimate loads, shear	C25/30 V_{um}	[kN]	5,0	7,0	6,9	12,8	7,2	20,3	21,1	29,5
Recommended loads, tension	C20/25 rec. N	[kN]	4,3	4,8	5,6	5,6	7,5	7,5	10,2	10,2
	C25/30 rec. N	[kN]	4,3	5,2	6,2	6,2	8,2	8,2	11,3	11,3
	C30/37 rec. N	[kN]	4,3	5,3	6,9	6,9	9,1	9,1	12,5	12,5
	C40/50 rec. N	[kN]	4,3	5,3	8,0	8,0	10,6	10,6	14,4	14,4
	C50/60 rec. N	[kN]	4,3	5,3	8,1	8,7	11,4	11,1	15,9	15,9
Recommended loads, shear	\geq C20/25 rec. V	[kN]	2,9	3,2	3,9	5,3	4,1	6,7	14,2	15,8
Recommended bending moments	rec. M	[Nm]	4,2	4,9	10,9	12,0	28,0	23,9	45,6	41,9
Spacing and edge distance										
Effective anchorage depth	h_{ef}	[mm]	39		43		52		64	
Characteristic spacing	$s_{cr,N}$	[mm]	117		129		156		192	
Characteristic edge distance	$c_{cr,N}$	[mm]	58,5		64,5		78		96	
Minimum spacing	s_{min}	[mm]	50		55		75		90	
Minimum edge distance	c_{min}	[mm]	50		65		90		105	
Minimum thickness of concrete slab	h_{min}	[mm]	100		100		110		130	
Installation parameters										
Drill hole diameter	d_o	[mm]	8		10		12		16	
Diameter of clearance hole in the fixture	d_f	[mm]	7		9		12		14	
Depth of drill hole	h_i	[mm]	60		65		75		95	
Installation torque	T_{inst}	[Nm]	6		15		30		50	

For anchor designing, an easy to operate CD-ROM is available on request or can be downloaded at www.mkt.de.

Mechanical Heavy Duty Anchors

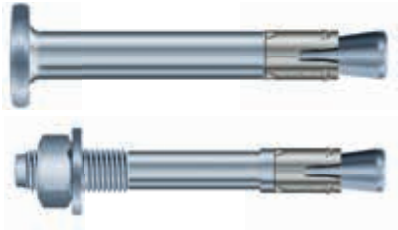


Installation



Nail Anchor N

Steel, zinc plated



Nail Anchor N-K

Nail Anchor N



Description

The Nail anchor N combines the advantages of a wedge Anchor with easier installation. The Nail Anchor is simply hammered through the construction piece into the drill-hole. The application of a torque is not necessary even with the threaded version. The hammering step sets the sleeve in the concrete.

There is a nailhead (N-K) and a threaded version M6 (N) available.

Range of loading: 0,71 kN - 2,81 kN

Range of concrete quality: C12/15 - C50/60

Advantages

- ETA approval for redundant fastenings in cracked concrete
- Fast and simple mounting
- Reduced anchoring depth (25 mm) for reduced drilling cost
- Very small edge distances and spacings.
- Loads up to 2,81 kN

Applications

Ceiling constructions, piping, cladding etc.



Nail Anchor N-K



→ Steel, zinc plated

→ With Nailhead

Description	Ref. No.	Drill hole		Setting depth		Fixture thickness		Anchor-length l mm	Pkg. content pcs.	Weight per pkg. kg	
		Ø mm	mm	mm	mm	t _{fx} mm	t _{fx,red} ¹⁾ mm				
N-K 6-0-5/39	72105101	6	40	35	36	31	0	5	39	200	2,01
N-K 6-5-10/44	72110101	6	40	35	36	31	5	10	44	200	2,27
N-K 6-30-35/69	72135101	6	40	35	36	31	30	35	69	200	3,40
N-K 6-50-55/89	72155101	6	40	35	36	31	50	55	89	100	2,15

¹⁾Reduced anchorage depth (observe reduced loads)

Nail Anchor N



→ Steel, zinc plated

→ With thread M6

Description	Ref. No.	Drill hole		Setting depth		Fixture thickness		Anchor-length l mm	Pkg. content pcs.	Weight per pkg. kg	
		Ø mm	mm	mm	mm	t _{fx} mm	t _{fx,red} ¹⁾ mm				
N 6-0-5/44	72005101	6	40	35	36	31	0	5	44	200	2,20
N 6-5-10/49	72010101	6	40	35	36	31	5	10	49	200	2,40
N 6-10-15/54	72015101	6	40	35	36	31	10	15	54	200	2,60

¹⁾Reduced anchorage depth (observe reduced loads)
Stainless steel A4 and HCR on demand



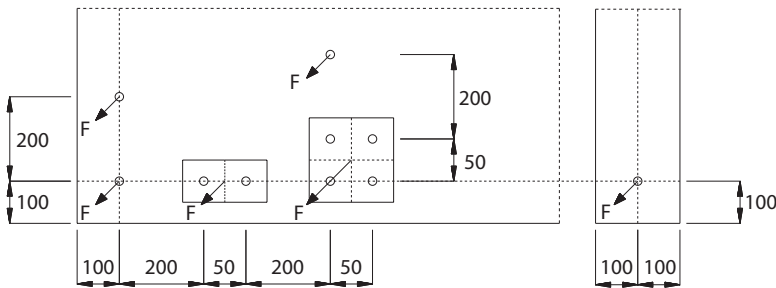
Extract from Permissible Service Conditions of ETA-11/0240

Multiple use for non-structural applications.
Total safety factor as per ETAG 001 included (γ_M and γ_P).

Loads and performance data	Nail Anchor	N 6				N-K	
		cracked / non-cracked concrete					
Effective anchorage depth	h_{ef} [mm]	25	30	25	30		
Approved loads (Picture 1)	C12/15 appr.F [kN]	1,43	1,90	1,43	1,90		
	C20/25 - C50/60 appr.F [kN]	2,14	2,81	2,14	2,81		
Approved loads (Picture 2)	C12/15 appr.F [kN]	0,71	0,95	0,71	0,95		
	C20/25 - C50/60 appr.F [kN]	0,95	1,19	0,95	1,19		
Approved bending moments	appr.M [Nm]	5,3	5,3	7,3	7,3		
Minimum thickness of concrete slab	h_{min} [mm]	80	80	80	80		
Installation parameters							
Drill hole diameter	d_o [mm]	6	6	6	6		
Diameter of clearance hole in the fixture	d_r [mm]	7	7	7	7		
Diameter nailhead	[mm]	-	-	13	13		
Depth of drill hole	h_1 [mm]	35	40	35	40		
Installation torque	$\leq T_{inst}$ [Nm]	4	4	-	-		

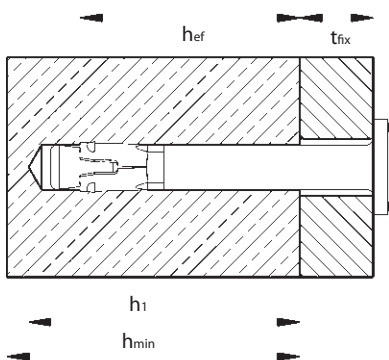
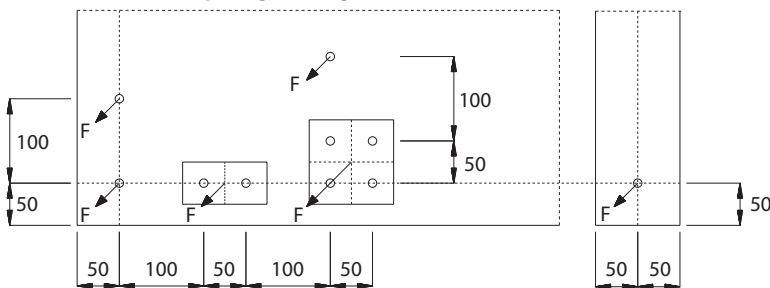
Respective spacing and edge distances [mm]:

Picture 1: maximum loads



The approved load F is for one fixing point.
One fixing point can be:
 • **Single anchor,**
 • **Pair of anchors** with spacing $s \geq 50$ mm or
 • **Group of four anchors** with $s \geq 50$ mm

Picture 2: minimum spacing and edge distance



Installation



Mechanical Heavy Duty Anchors

Drop-in Anchor E / ES

Steel, zinc plated



Drop-in Anchor E

Drop-in Anchor ES
(lipped)

Description

European approved Drop-in Anchor E (ETA, Option 7): Deformable expansion cone adjusts to strength of concrete as well as to size of hole within the variation range of a drill bit from new to worn. The anchor assures easy and safe fastening. The shoulder of the setting tool contacts the anchor in any case. The marking setting tool leaves four significant marks on each anchor as proof of correct expansion.

Applications

Attaching suspended ceilings, ventilation and sprinkler systems, structural steel, brackets, threaded rods.

Range of loading: 1,2 kN - 28,6 kN

Range of concrete quality: C20/25 - C50/60

Drop-in Anchor E



→ Steel, zinc plated

→ Approved for concrete

Description	Ref. No.	Drill hole Ø x depth mm	Thread Ø x length mm	Package content pcs.	Weight per package kg
E M 5 ¹	05000101	8 x 25	M5 x 10	100	0,74
E M 6	05005101	8 x 30	M6 x 13	100	0,84
E M 8	05100101	10 x 30	M8 x 13	100	1,17
E M 8 x 40	05105101	10 x 40	M8 x 20	100	1,49
E M 10	05200101	12 x 40	M10 x 15	50	1,07
E M 12	05300101	15 x 50	M12 x 18	50	2,18
E M 12 x 80	05305101	15 x 80	M12 x 45	50	3,15
E M 16	05500101	20 x 65	M16 x 23	25	2,55
E M 16 x 80	05505101	20 x 80	M16 x 38	25	2,91
E M 20	05600101	25 x 80	M20 x 34	25	4,45

Drop-in Anchor ES

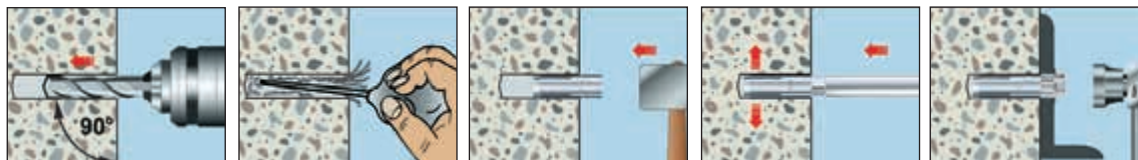


→ Steel, zinc plated, approved for concrete

→ Lipped Drop-in for installations in a bottomless hole

Description	Ref. No.	Drill hole Ø x depth mm	Thread Ø x length mm	Package content pcs.	Weight per package kg
ES M 8	05150101	10 x 30	M8 x 13	100	1,15
ES M 8 x 40	05155101	10 x 40	M8 x 20	100	1,53
ES M 10 x 30	05230101	12 x 30	M10 x 12	50	0,89
ES M 10	05250101	12 x 40	M10 x 15	50	1,10
ES M 12	05350101	15 x 50	M12 x 18	50	2,15

Installation



Drop-in Anchor E / ES

Hole drilled with a new drill bit in concrete C20/25:

→ Cone is not deformed during installation



Drop-in Anchor E / ES

- small drill hole
- concrete C50/60

→ Cone is deformed during installation



The setting tool E-MSW and E-MSH leaves four significant marks on each anchor as proof of correct expansion.



M6 - M20



M6 - M12



approved
M10 - M20



R30-R120
M6 - M20



Standard Setting Tool

for Drop-in Anchor E, ED and ES



Description	Ref. No.
E-SW 5	09000150
E-SW 6	09005150
E-SW 8	09100150
E-SW 8 x 40	09105150
E-SW 10	09200150
E-SW 10 x 30	09205150
E-SW 12	09300150
E-SW 12 x 80	09305150
E-SW 16	09500150
E-SW 16 x 80	09505150
E-SW 20	09600150

Safety Setting Tool

for Drop-in Anchor E and ES



Without Hand Guard		Safety Setting Tool with Hand Guard	
Description	Ref. No.	Description	Ref. No.
E-MSW 8	09100170	E-MSH 8	09100801
E-MSW 8 x 40	09105170	E-MSH 8 x 40	09105801
E-MSW 10	09200170	E-MSH 10	09200801
-	-	E-MSH 10 x 30	09205801
E-MSW 12	09300170	E-MSH 12	09300801
E-MSW 12 x 80	09305170	E-MSH 12 x 80	09305801
E-MSW 16	09500170	E-MSH 16	09500801
E-MSW 16 x 80	09505170	E-MSH 16 x 80	09505801
E-MSW 20	09600170	E-MSH 20	09600801



Extract from Permissible Service Conditions of ETA-02/0020

Approved loads for single anchor without influence of spacing and edge distance.
Total safety factor as per ETAG 001 included (γ_M and γ_p)

Loads and performance data	Drop-in Anchor	E M 5 ^{1,2)}	E M 6 ¹⁾	E/ES M 8 ¹⁾	E/ES M 8x40	E/ES M 10	ES M 10x30 ¹⁾	E/ES M 12	E M 16	E M 20	
											non-cracked concrete
Mean ultimate loads, tension (Screw 8.8)	C25/30 N _{um}	[kN]	8,0	10,0	11,5	13,5	16,9	15,6	24,1	36,4	50,5
Mean ultimate loads, shear (Screw 8.8)	C25/30 V _{um}	[kN]	5,7	6,9	11,1	11,1	13,5	13,5	29,5	50,4	76,4
Approved loads, tension (Screw 5.6 to 8.8)	C20/25 appr. N	[kN]	1,4	3,3	2,8	3,6	5,1	3,3	7,1	10,5	14,3
	C25/30 appr. N	[kN]	1,5	3,6	3,1	3,9	5,6	3,6	7,8	11,5	15,7
	C30/37 appr. N	[kN]	1,7	3,6	3,4	4,1	6,2	4,0	8,6	12,8	17,5
	C40/50 appr. N	[kN]	1,9	3,6	4,0	4,4	7,1	4,6	10,0	14,8	20,2
	C50/60 appr. N	[kN]	2,1	3,6	4,4	4,6	7,8	5,1	11,0	16,2	22,2
Approved loads, shear (Screw 5.6)	≥ C20/25 appr. V	[kN]	1,5	2,1	3,9	3,9	4,1	3,9	9,0	16,8	26,2
Approved loads, shear (Screw 5.8/8.8)	≥ C20/25 appr. V	[kN]	2,0	2,9	3,9	3,9	4,1	3,9	12,0	18,0	28,6
Approved bending moments (Screw 5.6)	appr. M	[Nm]	-	3,3	8,1	8,1	15,8	15,8	27,8	71,0	138,6
Approved bending moments (Screw 5.8)	appr. M	[Nm]	-	4,3	10,9	10,9	21,1	21,1	37,1	94,9	185,1
Approved bending moments (Screw 8.8)	appr. M	[Nm]	-	6,9	17,1	17,1	34,3	33,7	60,0	152,0	296,6
Spacing and edge distance											
Effective anchorage depth	h _{ef}	[mm]	25	30	30	40	40	30	50	65	80
Characteristic spacing	s _{cr,N}	[mm]	75	90	90	120	120	90	150	195	240
Characteristic edge distance	c _{cr,N}	[mm]	37,5	45	45	60	60	45	75	97,5	120
Minimum spacing	s _{min}	[mm]	60	55	60	80	100	100	120	150	160
Minimum edge distance	c _{min}	[mm]	95	95	95	95	135	115	165	200	260
Minimum thickness of concrete slab	h _{min}	[mm]	100	100	100	100	120	120	130	160	200
Installation parameters											
Drill hole diameter	d _o	[mm]	8	8	10	10	12	12	15	20	25
Diameter of clearance hole in the fixture	d _f	[mm]	6	7	9	9	12	12	14	18	22
Depth of drill hole	h _o	[mm]	25	30	30	40	40	30	50/80 ³⁾	65/80 ⁴⁾	80
Installation torque	T _{inst}	[Nm]	3	4	8	8	15	15	35	60	120
Minimum screwing depth	L _{sd}	[mm]	6	7	9	9	11	10	13	18	22
Maximum screwing depth	L _{th}	[mm]	10	13	13	20	15	12	18/45 ³⁾	23/38 ⁴⁾	34

¹⁾ Valid only for statically indeterminate systems.

³⁾ E / ES M12 / E M12x80

²⁾ Not part of approval.

⁴⁾ E M16 / E M16x80



Extract from Permissible Service Conditions of ETA-05/0116

Multiple use for non-structural applications.
Total safety factor as per ETAG 001 included (γ_M and γ_p).

Loads and performance data	Drop-in Anchor	E / ES	M 6	M 8	M 8x40	M 10	M 12
Approved loads (C20/25 to C50/60)	appr. F	[kN]	1,2	1,7	2,0	2,0	2,4
Approved bending moments (Steel 4.6)	appr. M	[Nm]	2,6	6,4	6,4	12,8	22,2
Approved bending moments (Steel 5.6)	appr. M	[Nm]	3,3	8,1	8,1	15,8	27,8
Approved bending moments (Steel 5.8)	appr. M	[Nm]	4,3	10,9	10,9	21,1	37,1
Approved bending moments (Steel 8.8)	appr. M	[Nm]	6,9	17,1	17,1	34,3	60,0
Spacing and edge distance							
Effective anchorage depth	h _{ef}	[mm]	30	30	40	40	50
Characteristic spacing	s _{cr}	[mm]	130	180	210	170	170
Characteristic edge distance	c _{cr}	[mm]	65	90	105	85	85
Minimum spacing	s _{min}	[mm]	55	60	80	100	120
Minimum edge distance	c _{min}	[mm]	95	95	95	135	165
Minimum thickness of concrete slab	h _{min}	[mm]	100	100	100	120	130
Installation parameters							
Drill hole diameter	d _o	[mm]	8	10	10	12	15
Diameter of clearance hole in the fixture	d _f	[mm]	7	9	9	12	14
Depth of drill hole	h _o	[mm]	30	30	40	40	50
Installation torque	T _{inst}	[Nm]	4	8	8	15	35
Minimum screwing depth	L _{sd}	[mm]	7	9	9	11	13
Maximum screwing depth	L _{th}	[mm]	13	13	20	15	18
Loads under fire exposure (Screw 5.6 to 8.8)							
Approved loads R30	appr. F	[kN]	0,8	0,9	0,9	1,5	1,5
Approved loads R60	appr. F	[kN]	0,8	0,9	0,9	1,5	1,5
Approved loads R90	appr. F	[kN]	0,4	0,9	0,9	1,5	1,5
Approved loads R120	appr. F	[kN]	0,2	0,4	0,4	1,0	1,2
Characteristic spacing	s _{cr,fi}	[mm]	130	180	210	170	200
Characteristic edge distance	c _{cr,fi}	[mm]	65	90	105	85	100
Minimum spacing	s _{min}	[mm]	55	60	80	100	120
Minimum edge distance	c _{min}	[mm]	95	95	95	135	165

For anchor designing, an easy to operate CD-ROM is available on request or can be downloaded at www.mkt.de.

Drop-in Anchor ED

Steel, zinc plated



Description

The Drop-in Anchor ED is designed for temporary mounting or fastenings of machines that are to be moved at a later time. The ED M12 D version with reinforced anchor shell is especially designed for the fastening of core drilling machines.

Applications

Fastening of concrete processing tools such as core-drills and concrete saws.

Base Material: concrete C12/15 - C 50/60



Drop-in Anchor ED



→ Steel, zinc plated

→ Suitable for diamond drilling equipment

Description	Ref. No.	Drill hole Ø x depth mm	Thread Ø x length mm	Package content pcs.	Weight per package kg
ED M 12	05301101	15 x 50	M12 x 18	50	2,39
ED M 12 D	05317101	16 x 50	M12 x 18	50	2,81
ED M 16	05501101	20 x 65	M16 x 23	25	2,72

Standard Setting Tool

for Drop-in Anchor ED

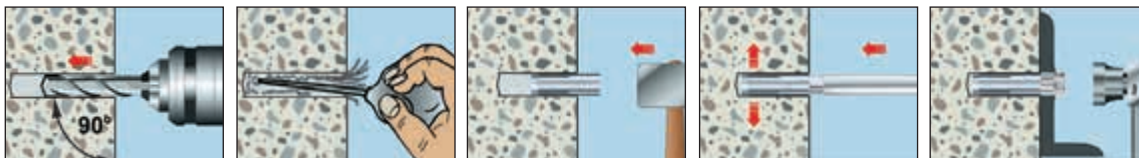


Description	Ref. No.
E-SW 12	09300150
E-SW 16	09500150

Recommended loads for Drop-in Anchor ED.
Total safety factor as per ETAG 001 included (γ_M and γ_P).

Loads and performance data	Drop-in Anchor	ED		
		M 12	M 12 D	M 16
non-cracked concrete				
Approved loads, tension (Screw 5.6 bis 8.8)	C20/25 appr. N [kN]	7,1	7,1	10,5
Approved loads, shear (Screw 5.6)	≥ C20/25 appr. V [kN]	9,0	9,0	16,8
Approved loads, shear (Screw 5.8/8.8)	≥ C20/25 appr. V [kN]	12,0	12,0	18,0
Approved bending moments (Screw 5.6)	appr. M [Nm]	27,8	27,8	71,0
Approved bending moments (Screw 5.8)	appr. M [Nm]	37,1	37,1	94,9
Approved bending moments (Screw 8.8)	appr. M [Nm]	60,0	60,0	152,0
Spacing and edge distance				
Effective anchorage depth	h_{ef} [mm]	50	50	65
Characteristic spacing	$s_{cr,N}$ [mm]	150	150	195
Characteristic edge distance	$c_{cr,N}$ [mm]	75	75	97,5
Minimum spacing	s_{min} [mm]	120	120	150
Minimum edge distance	c_{min} [mm]	165	165	200
Minimum thickness of concrete slab	h_{min} [mm]	130	130	160
Installation parameters				
Drill hole diameter	d_o [mm]	15	16	20
Diameter of clearance hole in the fixture	d_f [mm]	14	14	18
Depth of drill hole	h_o [mm]	50	50	65
Installation torque	T_{inst} [Nm]	35	35	60
Minimum screwing depth	L_{sd} [mm]	13	13	18
Maximum screwing depth	L_{th} [mm]	18	18	23

Installation



Drop-in Anchor ED-DW 15

Steel, zinc plated



Description

Drop-in Anchor with DYWIDAG® internal thread¹⁾ DW 15 for post installed threadbar (DYWIDAG®) connections. Suitable for concrete C12/15 or hard natural stone. Safe installation if debris makes the thread impassible. The Drop-in Anchor does not protrude out of the concrete after removing the threadbar.

Applications

Multi-functional Anchor for concrete formwork. Cost efficient, quick fixing into existing concrete. Ideal for fixing one-sided formwork or temporary guardrails.

Base Material: concrete C 12/15 - C 50/60
or hard natural stone



Drop-in Anchor ED-DW 15



- Steel, zinc plated
- For fixing threadbars in formwork

Description	Ref. No.	Drill hole Ø x depth mm	Thread Ø x length mm	Package content pcs.	Weight per package kg
ED-DW 15	05950101	22 x 80	DW 15 x 35	25	3,76

Standard Setting Tool

for Drop-in Anchor ED-DW 15



Description	Ref. No.
E-SW 16x80 / DW-15	9505150

Recommended loads for ED-DW 15.

Total safety factor as per ETAG 001 included (γ_M and γ_F).

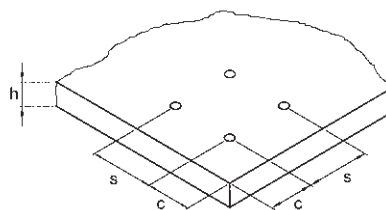
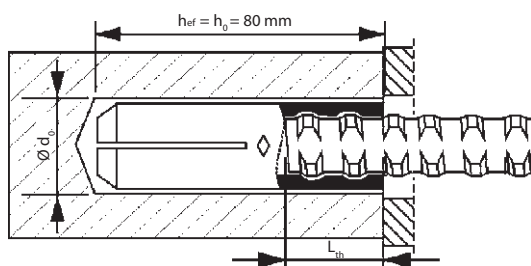
Loads and performance data	Applied load angle	0°	15°	30°	45°	60°	75°	90°	
									non-cracked concrete
Recommended loads	C12/15	rec. F [kN]	17,3	16,9	16,8	17,4	18,7	20,6	22,6
	≥ C20/25	rec. F [kN]	19,3	18,7	18,3	18,6	19,5	21,1	22,6

Spacing and edge distance

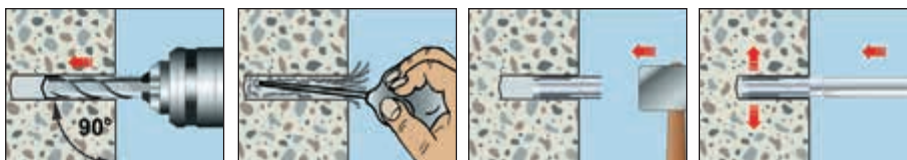
Effective anchorage depth	h_{ef}	[mm]	80
Minimum spacing	s_{min}	[mm]	600
Minimum edge distance	c_{min}	[mm]	300
Minimum thickness of concrete slab	h_{min}	[mm]	160

Installation parameters

Drill hole diameter	d_o	[mm]	22
Depth of drill hole	h_o	[mm]	80
Length of thread	L_{th}	[mm]	35
Bar/Screw DW 15 minimum installation depth	[mm]		28



Installation



¹⁾ DYWIDAG® internal thread (DYWIDAG® is a registered trademark of Walter Bau AG)

Drop-in Anchor E A4 / E HCR

Stainless steel A4/316 / High corrosion resistant steel 1.4529 (HCR)



Drop-in Anchor E A4 / E HCR



Description

European approved Drop-in Anchor E A4 and E HCR (ETA, Option 7): Deformable expansion cone adjusts to strength of concrete as well as to size of hole within the variation range of a drill bit from new to worn. The anchor assures easy and safe fastening. The shoulder of the setting tool contacts the anchor in any case. The marking setting tool leaves four significant marks on each anchor as proof of correct expansion.

Applications

Attaching suspended ceilings, ventilation and sprinkler systems, structural steel, brackets, threaded rods.



Drop-in Anchor E A4 / E HCR

Hole drilled with a new drill bit in concrete C20/25:

→ Cone is not deformed during installation



Drop-in Anchor E A4 / HCR

- small drill hole
- concrete C50/60

→ Cone is deformed during installation



The setting tool E-MSW and E-MSH leaves four significant marks on each anchor as proof of correct expansion.

Range of loading: 1,2 kN - 30,4 kN

Range of concrete quality: C20/25 - C50/60



Drop-in Anchor E A4



→ Stainless steel A4/316

→ Approved for concrete

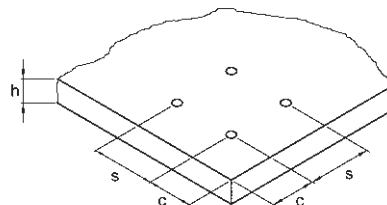
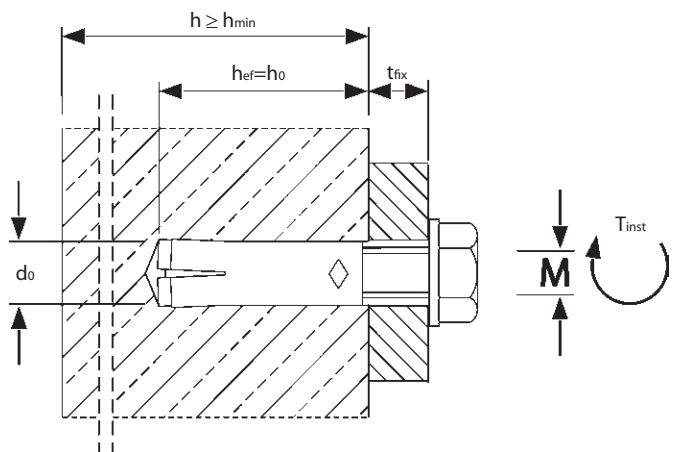
Description	Ref. No.	Drill hole Ø x depth mm	Thread Ø x length mm	Package content pcs.	Weight per package kg
E M 5 A4 ¹⁾	05000501	8 x 25	M5 x 10	100	0,75
E M 6 A4	05005501	8 x 30	M6 x 13	100	0,83
E M 8 A4	05100501	10 x 30	M8 x 13	100	1,16
E M 8 x 40 A4	05105501	10 x 40	M8 x 20	100	1,49
E M 10 A4	05200501	12 x 40	M10 x 15	50	1,08
E M 12 A4	05300501	15 x 50	M12 x 18	50	2,19
E M 16 A4	05500501	20 x 65	M16 x 23	25	2,57
E M 20 A4	05600501	25 x 80	M20 x 34	25	4,63

¹⁾ Not part of approval.

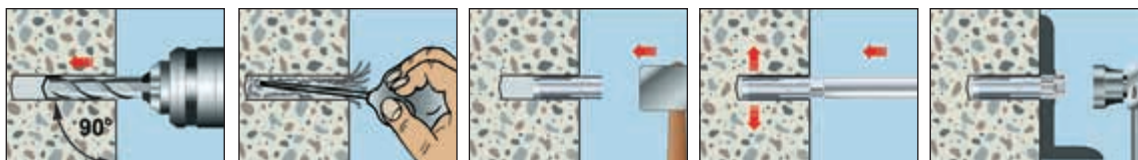
High corrosion resistant steel 1.4529 (HCR) on demand.

Setting tool E-MSW, E-MSH and E-SW see page 30.

Coated screws see page 16.



Installation





Extract from Permissible Service Conditions of ETA-02/0020

Approved loads for single anchor without influence of spacing and edge distance.
Total safety factor as per ETAG 001 included (γ_M and γ_P).

Loads and performance data	Drop-in Anchor E A4 / E HCR		M 5 ¹⁾	M 6 ¹⁾	M 8 ¹⁾	M 8x40	M 10	M 12 ²⁾	M 16 ²⁾	M 20 ²⁾
non-cracked concrete										
Mean ultimate loads, tension	C25/30 N _{um}	[kN]	8,0	12,2	14,2	16,1	19,8	27,7	41,0	62,7
Mean ultimate loads, shear	C25/30 V _{um}	[kN]	5,7	8,5	14,1	14,8	20,3	37,3	64,9	94,6
Approved loads, tension	C20/25 appr. N	[kN]	1,6	3,9	3,9	4,3	6,1	8,5	12,6	17,2
	C25/30 appr. N	[kN]	1,7	4,3	4,3	4,7	6,7	9,3	13,8	18,9
	C30/37 appr. N	[kN]	1,9	4,8	4,8	5,2	7,4	10,4	15,3	21,0
	C40/50 appr. N	[kN]	2,2	5,4	5,6	6,0	8,6	12,0	17,7	24,2
	C50/60 appr. N	[kN]	2,5	5,4	6,1	6,6	9,4	13,2	19,5	26,6
Approved loads, shear	≥ C20/25 appr. V	[kN]	2,3	3,2	4,9	4,9	6,1	11,5	19,2	30,4
Approved bending moments (Screw A4-70)	appr. M	[Nm]	-	5,0	11,9	11,9	23,8	42,1	106,7	207,9
Spacing and edge distance										
Effective anchorage depth	h _{ef}	[mm]	25	30	30	40	40	50	65	80
Characteristic spacing	s _{cr,N}	[mm]	75	90	90	120	120	150	195	240
Characteristic edge distance	c _{cr,N}	[mm]	37,5	45	45	60	60	75	97,5	120
Minimum spacing	s _{min}	[mm]	60	50	60	80	100	120	150	160
Minimum edge distance	c _{min}	[mm]	95	80	95	95	135	165	200	260
Minimum thickness of concrete slab	h _{min}	[mm]	100	100	100	100	130	140	160	250
Installation parameters										
Drill hole diameter	d _o	[mm]	8	8	10	10	12	15	20	25
Diameter of clearance hole in the fixture	d _f	[mm]	6	7	9	9	12	14	18	22
Depth of drill hole	h _o	[mm]	25	30	30	40	40	50	65	80
Installation torque	T _{inst}	[Nm]	3	4	8	8	15	35	60	120
Minimum screwing depth	L _{sd}	[mm]	6	7	9	9	11	13	18	22
Maximum screwing depth	L _{th}	[mm]	10	13	13	20	15	18	23	34

¹⁾ Valid only for statically indeterminate systems. Size M 5 not part of approval.

²⁾ The approval of sizes M12, M16 and M20 is valid for stainless steel A4.

For anchor designing, an easy to operate CD-ROM is available on request or can be downloaded at www.mkt.de.



Extract from Permissible Service Conditions of ETA-05/0116

Multiple use for non-structural applications.
Total safety factor as per ETAG 001 included (γ_M and γ_P).

Loads and performance data	Drop-in Anchor E A4 / E HCR		M 6	M 8	M 8x40	M 10	M 12
cracked and non-cracked concrete							
Approved loads (C20/25 to C50/60)	appr. F	[kN]	1,2	1,7	2,0	2,0	2,4
Approved bending moments (A4-70)	appr. M	[Nm]	5,0	11,9	11,9	23,8	42,1
Spacing and edge distance							
Effective anchorage depth	h _{ef}	[mm]	30	30	40	40	50
Characteristic spacing	s _{cr}	[mm]	130	180	210	170	170
Characteristic edge distance	c _{cr}	[mm]	65	90	105	85	85
Minimum spacing	s _{min}	[mm]	50	60	80	100	120
Minimum edge distance	c _{min}	[mm]	80	95	95	135	165
Minimum thickness of concrete slab	h _{min}	[mm]	100	100	100	130	140
Installation parameters							
Drill hole diameter	d _o	[mm]	8	10	10	12	15
Diameter of clearance hole in the fixture	d _f	[mm]	7	9	9	12	14
Depth of drill hole	h _o	[mm]	30	30	40	40	50
Installation torque	T _{inst}	[Nm]	4	8	8	15	35
Minimum screwing depth	L _{sd}	[mm]	7	9	9	11	13
Maximum screwing depth	L _{th}	[mm]	13	13	20	15	18
Loads under fire exposure							
Approved loads R30	appr. F	[kN]	0,8	0,9	0,9	1,5	1,5
Approved loads R60	appr. F	[kN]	0,8	0,9	0,9	1,5	1,5
Approved loads R90	appr. F	[kN]	0,4	0,9	0,9	1,5	1,5
Approved loads R120	appr. F	[kN]	0,2	0,4	0,4	1,0	1,2
Characteristic spacing	s _{cr,fi}	[mm]	130	180	210	170	200
Characteristic edge distance	c _{cr,fi}	[mm]	65	90	105	85	100
Minimum spacing	s _{min}	[mm]	50	60	80	100	120
Minimum edge distance	c _{min}	[mm]	80	95	95	135	165

For anchor designing, an easy to operate CD-ROM is available on request or can be downloaded at www.mkt.de.

Hollow Core Anchor Easy

Steel, zinc plated



Easy

Description

The Hollow-Core Anchor Easy is a one-piece unit, specially designed for anchoring in pre-stressed hollow concrete slabs. Tightening the screw or nut pulls the expansion cone inside the anchor sleeve which keys into the cavity or provides strong expansion in solid concrete. The approval Z-21.1-1785 allows the anchor to be installed even if the drill hole does not hit the cavity.

Applications

Suspension of ventilation, sprinkler system, false ceilings, brackets with threaded studs or screws, ducts, anchoring prefabricated panels on hollow concrete floors/ceilings.

Range of loading: 0,7 kN - 4,3 kN
Concrete quality: ≥ C45/55 respectively B55;
 pre-stressed hollow concrete slabs



Advantages:

- Simple and flexible to use
- Even approved if the drill hole does not hit the cavity
- To be used with standard screws or threaded rods



Hollow Core Anchor Easy



- Steel, zinc plated
- For pre-stressed hollow concrete slabs

Description	Ref. No.	Drill hole Ø mm	Thread Ø mm	Package content pieces	Weight per package kg
Easy M 6	51005101	10	M 6	50	0,52
Easy M 8	51100101	12	M 8	50	0,72
Easy M 10	51200101	16	M 10	50	1,66
Easy M 12	51300101	18	M 12	25	1,08

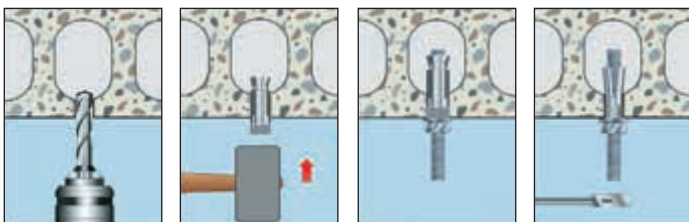
Note on the used screws:

- The screws must have a sufficiently long thread in order to expand the anchor safely.
- Recommended screws to be used DIN 933 / DIN EN ISO 898
- The required screw length is determined by the „minimum length of screw“ (see table page 37) + the thickness of the fixture (tfix)
- screws M6 at least have the strength 8.8
 M8 - M12 at least 5.8

Note to the threaded stud and nuts used:

- The minimum required stud length is determined by the „minimum length of stud“ (see table page 37) + the thickness of the fixture (tfix), if exist
- M6 threaded stud must have at least the strength of 8.8,
 M6 nut must have strength class 8
- M8-M12 threaded stud must have at least the strength of 5.8,
 M8-M12 nut must have strength class 5

Installation





Extract from Permissible Service Conditions of Z-21.1-1785

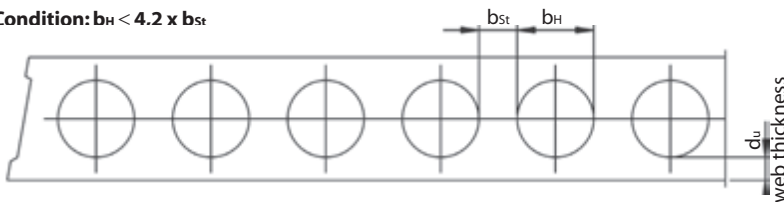
Approved loads for single anchor without influence of spacing and edge distance.
Total safety factor as per ETAG 001 included (γ_M and γ_F).

Loads and performance data	Easy	M 6				M 8				M 10				M 12				
		Pre-stressed hollow concrete slabs \geq C45/55																
Web thickness	d_u [mm]	\geq	25	30	40	50	25	30	40	50	25	30	40	50	25	30	40	50
Single anchor																		
Approved loads ¹⁾ (for $c \geq C_{cr}$)	$F^{(1)}$ [kN]		0,7	0,9	2,0	2,9	0,7	0,9	2,0	3,6	0,9	1,2	3,0	3,6	1,0	1,2	3,0	4,3
Edge distance	C_{cr} [mm]		150				150				150				150			
Approved loads ¹⁾ (for C_{min})	$F^{(1)}$ [kN]		0,35	0,8	1,8	2,4	0,35	0,8	1,8	3,0	0,8	1,0	2,7	3,0	0,8	1,0	2,7	3,6
Minimum edge distance	C_{min} [mm]		100				100				100				100			
Spacing	S_{cr} [mm]		300				300				300				300			
Pair of anchors²⁾																		
Approved loads ¹⁾ (for $c \geq C_{cr}$)	$F^{(1)}$ [kN]		0,7	1,4	2,6	3,9	0,7	1,4	2,6	4,8	1,1	2,0	4,8	4,8	1,2	2,0	4,8	5,7
Minimum spacing	S_{min} [mm]		70	80	100	100	70	80	100	100	70	80	100	100	70	80	100	100
Edge distance	C_{cr} [mm]		150				150				150				150			
Approved loads ¹⁾ (for C_{min})	$F^{(1)}$ [kN]		0,35	1,25	2,35	3,2	0,35	1,25	2,35	4,0	0,9	1,8	4,3	4,3	1,0	1,8	4,3	4,8
Minimum spacing	S_{min} [mm]		70	80	100	100	70	80	100	100	70	80	100	100	70	80	100	100
Minimum edge distance	C_{min} [mm]		100				100				100				100			
Approved bending moments																		
Stud / Screw, steel 5.8	[Nm]		-				10,7				21,4				37,4			
Stud / Screw, steel 8.8	[Nm]		4,4				17,1				34,2				59,8			
Installation parameters																		
Length of sleeve (without cone)	L [mm]		30				35				40				45			
Minimum length of screw	min l_s [mm]		42 + t_{fix}				47 + t_{fix}				55 + t_{fix}				61 + t_{fix}			
Minimum length of stud	min l_b [mm]		47 + t_{fix}				53 + t_{fix}				63 + t_{fix}				71 + t_{fix}			
Minimum strength of stud / screw			8,8				5,8				5,8				5,8			
Drill hole diameter	d_o [mm]		10				12				16				18			
Clearance hole in the fixture	d_f [mm]		7				9				12				14			
Depth of drill hole	h_o [mm]		50				55				60				70			
Installation torque	T_{inst} [Nm]		10				20				30				40			

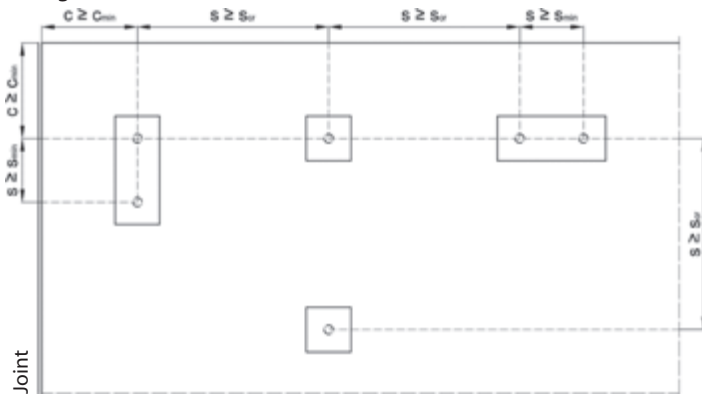
¹⁾ For edge distance $c_{min} < c \leq C_{cr}$ can be determined by linear interpolation.

²⁾ Approved loads valid for double anchorage. Recommended load of the most stressed anchor may not exceed the recommended load of a single anchor. On double anchorages with spacing $S_{min1,2} < S_{1,2} < S_{cr1,2}$ the recommended load may be determined by linear interpolation, assuming the limiting value $S_{1,2} = S_{cr1,2}$ for the double anchorage exposed to tension is twice the recommended load of a single anchor.

Condition: $b_H < 4.2 \times b_{St}$

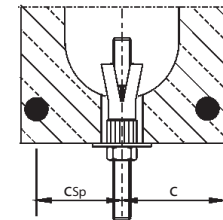


Arrangement of the anchors

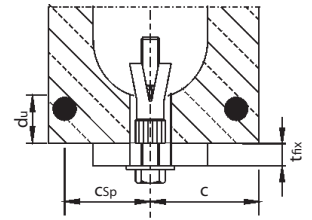


Installation with a threaded stud

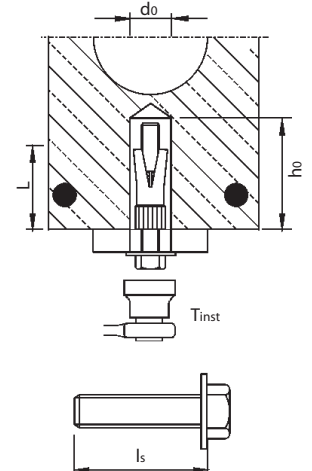
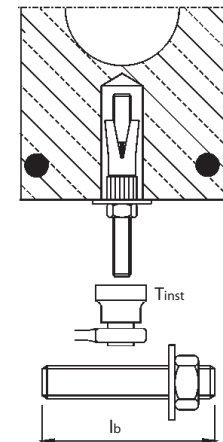
Hollow



Installation with a screw



Solid

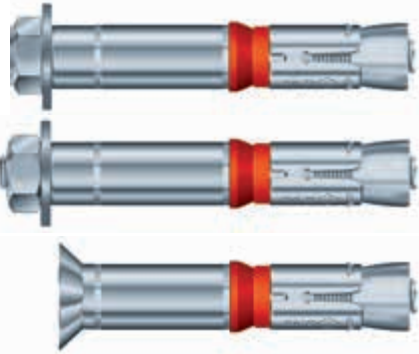


- t_{fix} = Fixture thickness
- d_u = Web thickness
- b_H = Width of hollow
- b_{St} = Width of web
- c_{Sp} = Spacing to tension wire
- c = Edge distance

Mechanical Heavy Duty Anchors

Highload Anchor SZ

Steel, zinc plated



Highload Anchor SZ-S

Highload Anchor SZ-B

Highload Anchor SZ-SK



Description

The ETA (Option 1) approved Highload Anchor SZ is a high-performance through fastening Anchor System with three part expansion sleeve. This allows for smaller spacings and edge distances with high loads. The plastic compression ring ensures the clamping of the mounted piece to the work surface and stops the anchor from turning while being fastened. Three different models of The Highload Anchor SZ are available: Screw/washer SZ-S, Bolthead SZ-B and for flush surface mounting SZ-SK. All models have been shock-tested by the federal office for population protection in Bern/Switzerland.

Range of loading: 2,4 kN - 73,8 kN

Range of concrete quality: C20/25 - C50/60

Advantages

- High tension and shear loads
- Fire protection approved (See Page 105)
- Screw/washer (SZ-B) model and flat head (SZ-SK) model for finished surfaces
- Can be dismantled with a flush surface result (only the cone and expansion sleeve remain in the drill-hole)
- smaller spacings and edge distances

Applications

Medium to highload anchoring in cracked and non-cracked concrete, e.g. trusses, railings, machines, scaffolding and consoles.



Highload Anchor SZ



- Steel, zinc plated
- ETA approval for cracked and non-cracked concrete

Description	Type SZ-S	Type SZ-B	Drill hole Øxdepth	Setting- depth	Anchor- length		Fixture thick- ness t _{fix}	Thread	Pkg. cont.	Weight per pkg.
	Ref. No.	Ref. No.			Typ S mm	Typ B mm				
SZ 10-0	14005301	16005301	10x65	60	65	67	0	M 6	100	3,25
SZ 10-10	14010301	16010301	10x65	60	75	77	10	M 6	50	1,94
SZ 10-30	14025301	16025301	10x65	60	95	97	30	M 6	50	2,47
SZ 10-50	14030301	16030301	10x65	60	115	117	50	M 6	50	2,94
SZ 10-100	-	16045301	10x65	60	-	167	100	M 6	25	2,05
SZ 12-0	14105301	16105301	12x80	70	75	80	0	M 8	50	2,93
SZ 12-10	14110301	16110301	12x80	70	85	90	10	M 8	50	3,31
SZ 12-30	14125301	16125301	12x80	70	105	110	30	M 8	50	4,10
SZ 12-50	14130301	16130301	12x80	70	125	130	50	M 8	25	2,47
SZ 12-100	-	16145301	12x80	70	-	180	100	M 8	25	3,22
SZ 15-0	14205301	16205301	15x95	85	91	96	0	M 10	25	2,85
SZ 15-15	14215301	16215301	15x95	85	106	111	15	M 10	25	3,31
SZ 15-25	14220301	16220301	15x95	85	116	121	25	M 10	25	3,59
SZ 15-45	14225301	16225301	15x95	85	136	141	45	M 10	25	4,20
SZ 15-95	14240301	16240301	15x95	85	186	191	95	M 10	25	5,60
SZ 18-0	14305301	16305301	18x105	95	107	112	0	M 12	20	3,84
SZ 18-10	14310301	16310301	18x105	95	117	122	10	M 12	20	4,18
SZ 18-20	14315301	16315301	18x105	95	127	132	20	M 12	20	4,53
SZ 18-40	14325301	16325301	18x105	95	147	152	40	M 12	20	5,21
SZ 18-70	14335301	16335301	18x105	95	177	182	70	M 12	20	6,26
SZ 18-100	-	16340301	18x105	95	-	212	100	M 12	10	3,55
SZ 24-0	14505301	16505301	24x130	120	130	137	0	M 16	10	4,11
SZ 24-20	14515301	16515301	24x130	120	150	157	20	M 16	10	4,71
SZ 24-50	14525301	16525301	24x130	120	180	187	50	M 16	10	5,58
SZ 24-100	-	16530301	24x130	120	-	237	100	M 16	5	3,49
SZ 24-0 L	14555301	16555301	24x145	135	150	152	0	M 16	10	4,70
SZ 24-30 L	14565301	16565301	24x145	135	180	182	30	M 16	10	5,57
SZ 24-50 L	14575301	16575301	24x145	135	200	202	50	M 16	10	6,20
SZ 28-10	14610301	16610301	28x160	150	172	181	10	M 20	10	7,76
SZ 28-30	14615301	16615301	28x160	150	192	201	30	M 20	5	4,35
SZ 28-60	14625301	16625301	28x160	150	222	231	60	M 20	5	5,02
SZ 28-100	14630301	16630301	28x160	150	262	271	100	M 20	5	5,88

Highload Anchor SZ-SK



- Steel, zinc plated; with countersunk head
- ETA approval for cracked and non-cracked concrete

Description	Ref. No.	Drill hole Øxdepth	Setting- depth	Anchor- length	Fixture thickness t _{fix}	Thread	Pkg. cont.	Weight per pkg.
SZ-SK 10-10	14011801	10 x 65	60	70	10	M 6	50	1,69
SZ-SK 10-25	14021801	10 x 65	60	85	25	M 6	50	2,30
SZ-SK 10-40	14031801	10 x 65	60	100	40	M 6	50	2,58
SZ-SK 12-10	14111801	12 x 80	70	80	10	M 8	50	3,01
SZ-SK 12-25	14121801	12 x 80	70	95	25	M 8	50	3,65
SZ-SK 12-50	14131801	12 x 80	70	120	50	M 8	25	2,33
SZ-SK 15-10	14211801	15 x 95	85	95	10	M 10	25	2,79
SZ-SK 15-25	14221801	15 x 95	85	110	25	M 10	25	3,29
SZ-SK 15-35	14226801	15 x 95	85	120	35	M 10	25	3,55
SZ-SK 15-50	14231801	15 x 95	85	135	50	M 10	25	3,96
SZ-SK 18-20	14316801	18 x 105	95	115	20	M 12	20	3,99
SZ-SK 18-40	14326801	18 x 105	95	135	40	M 12	20	4,62

Other lengths and special assemblies on demand.



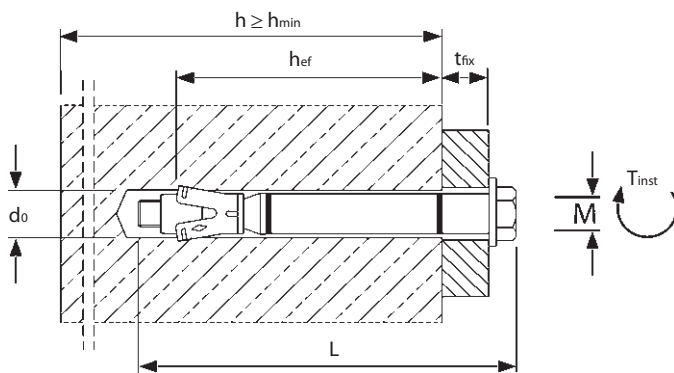
Extract from Permissible Service Conditions of ETA-02/0030

Approved loads for single anchor without influence of spacing and edge distance.
Total safety factor as per ETAG 001 included (γ_M and γ_P).

Loads and performance data	Highload Anchor SZ		SZ 10	SZ 12	SZ 15	SZ 18	SZ 24	SZ 24L	SZ 28	
			M 6	M 8	M 10	M 12	M 16	M 16	M 20	
cracked concrete										
Mean ultimate loads, tension	C25/30 N_{um}	[kN]	14,5	18,8	30,0	38,8	55,5	79,8	89,4	
Mean ultimate loads, shear	C25/30 V_{um}	[kN]	22,8	31,9	46,1	84,7	116,6	116,6	171,0	
Approved loads, tension	C20/25 appr. N	[kN]	2,4	5,7	7,6	12,3	17,1	21,1	24,0	
	C25/30 appr. N	[kN]	2,6	6,3	8,4	13,5	18,9	23,3	26,4	
	C30/37 appr. N	[kN]	2,9	7,0	9,3	15,0	20,9	25,8	29,2	
	C40/50 appr. N	[kN]	3,4	8,1	10,7	17,3	24,2	29,8	33,8	
	C50/60 appr. N	[kN]	3,7	8,9	11,8	19,0	26,6	32,8	37,1	
	non-cracked concrete									
Approved loads, tension	C20/25 appr. N	[kN]	7,6	9,5	14,3	17,2	24,0	29,6	33,5	
	C25/30 appr. N	[kN]	7,6	10,5	15,7	18,9	26,4	32,6	36,9	
	C30/37 appr. N	[kN]	7,6	11,6	17,4	21,0	29,3	36,1	40,9	
	C40/50 appr. N	[kN]	7,6	13,4	20,1	24,2	33,8	41,7	47,3	
	C50/60 appr. N	[kN]	7,6	13,8	21,9	26,6	37,2	45,9	52,0	
cracked concrete / non-cracked concrete										
Approved loads, shear SZ-S and SZ-SK	C20/25 appr. V	[kN]	10,1	15,9 / 17,1	20,5 / 27,5	24,5 / 34,3	34,3 / 48,0	42,3 / 59,2	47,9/67,1	
	\geq C25/30 appr. V	[kN]	10,1	17,1	22,6 / 27,5	27,0 / 37,8	37,7 / 52,8	46,5 / 65,1	52,7/73,8	
Approved loads, shear SZ-B	C20/25 appr. V	[kN]	9,1	14,0	20,5 / 20,7	24,5 / 34,3	34,3 / 48,0	42,3 / 52,1	47,9/67,1	
	\geq C25/30 appr. V	[kN]	9,1	14,0	20,7	27,0 / 36,1	37,7 / 52,1	46,5 / 52,1	52,7/69,7	
Approved bending moments	appr. M	[Nm]	6,9	17,1	34,3	60,0	152,0	152,0	296,6	
Spacing and edge distance										
Effective anchorage depth	h_{ef}	[mm]	50	60	71	80	100	115	125	
Characteristic spacing	$s_{cr,N}$	[mm]	150	180	213	240	300	345	375	
Characteristic edge distance	$c_{cr,N}$	[mm]	75	90	106,5	120	150	172,5	187,5	
Minimum spacing / for edge distance c	s_{min} / C	[mm]	50/80	60/100	70/120	80/160	100/180	100/180	125/300	
Minimum edge distance / for spacing s	c_{min} / S	[mm]	50/100	60/120	70/175	80/200	100/220	100/220	180/540	
Minimum thickness of concrete slab	h_{min}	[mm]	100	120	140	160	200	230	250	
Installation parameters										
Drill hole diameter	d_o	[mm]	10	12	15	18	24	24	28	
Diameter of clearance hole in the fixture	d_f	[mm]	12	14	17	20	26	26	31	
Depth of drill hole	h_1	[mm]	65	80	95	105	130	145	160	
Installation torque	T_{inst}	[Nm]	15/10 ¹⁾	30/25 ¹⁾	50/55 ¹⁾	80/70 ¹⁾	160	160	280	
Width across nut SZ (-S, -B)	SW	[mm]	10	13	17	19	24	24	30	
Internal hexagon size SZ-SK	SW _{Hex}	[mm]	4	5	6	8	-	-	-	
Minimum thickness of fixture for SZ-SK	$t_{fix} \geq$	[mm]	8	10	14	18	-	-	-	

¹⁾ Installation torque for type SZ-SK (with countersunk head).

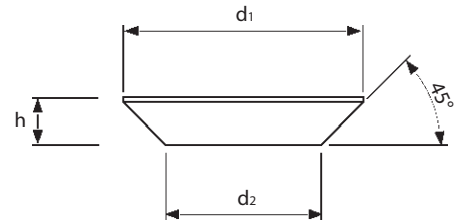
For anchor designing, an easy to operate CD-ROM is available on request or can be downloaded at www.mkt.de.



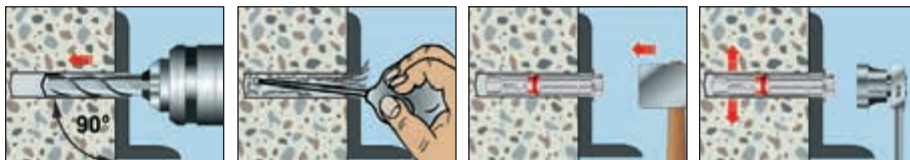
Dimensions countersunk head SZ-SK [mm]

	d1	d2	h
SZ-SK 10 M 6	16,5	9,5	3,9
SZ-SK 12 M 8	20,5	11,5	5,0
SZ-SK 15 M 10	24,5	14,5	5,7
SZ-SK 18 M 12	29,5	17,5	6,7

Countersunk head (type SZ-SK).

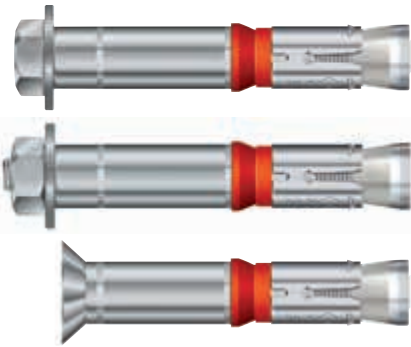


Installation



Highload Anchor SZ A4

Stainless steel A4



Highload Anchor SZ-S A4

Highload Anchor SZ-B A4

Highload Anchor SZ-SK A4



Description

The new SZ A4 is the stainless-steel version of the tried and tested Highload anchor SZ. It also possesses ETA (Option 1) approval. Highload Anchor SZ is a high-performance through fastening Anchor System with three part expansion sleeve. This allows for smaller spacings and edge distances with high loads. The plastic compression ring ensures the clamping of the mounted piece to the work surface and stops the anchor from turning while being fastened. Three different models of The Highload Anchor SZ are available: screw/washer SZ-S, Bolthead SZ-B and for a flush surface mounting SZ-SK. All models have been shock-tested by the federal office for population protection in Bern/Switzerland

Advantages

- High tension and shear loads
- Fire protection approved (See Page 105)
- Screw/washer (SZ-S) model and flat head (SZ-SK) model for finished surfaces
- Can be dismantled with a flush surface result (only the cone and expansion sleeve remain in the drill-hole)
- smaller spacings and edge distances

Applications

Medium to highload mounting in cracked and non-cracked concrete, e.g. trusses, railings, machines, scaffolding and consoles. Even in damp rooms and outdoors.

Loads: 4,3 kN - 52,6 kN
Concrete quality: C20/25 - C50/60



Highload Anchor SZ A4



- Stainless steel A4
- Approval for cracked and non-cracked concrete

Highload Anchor SZ-SK A4



- Stainless steel A4
- Approval for cracked and non-cracked concrete

Description	Typ SZ-S	Typ SZ-B	Drill hole Øxdepth	Setting-depth	Anchor-length l		Fixture thickness t _{fix}	Thread	Pkg. cont.	Weight per pkg.
					Typ S	Typ B				
	Ref. No.	Ref. No.	mm	mm	mm	mm	mm		pcs.	kg
SZ 12-0	14105501	16105501	12x80	70	75	79	0	M 8		2,93
SZ 12-10	14110501	16110501	12x80	70	85	89	10	M 8	pcs.	3,31
SZ 12-30	14125501	16125501	12x80	70	105	109	30	M 8	50	4,10
SZ 12-50	14130501	16130501	12x80	70	125	129	50	M 8	25	2,47
SZ 12-100	-	16145501	12x80	70	-	179	100	M 8	25	3,22
SZ 15-0	14205501	16205501	15x95	85	91	95	0	M 10	25	2,85
SZ 15-15	14215501	16215501	15x95	85	106	110	15	M 10	25	3,31
SZ 15-25	14220501	16220501	15x95	85	116	120	25	M 10	25	3,59
SZ 15-45	14225501	16225501	15x95	85	136	140	45	M 10	25	4,20
SZ 15-95	14240501	16240501	15x95	85	186	190	95	M 10	25	5,60
SZ 18-0	14305501	16305501	18x105	95	108	112	0	M 12	20	3,84
SZ 18-10	14310501	16310501	18x105	95	118	122	10	M 12	20	4,18
SZ 18-20	14315501	16315501	18x105	95	128	131	20	M 12	20	4,53
SZ 18-40	14325501	16325501	18x105	95	148	151	40	M 12	20	5,21
SZ 18-70	14335501	16335501	18x105	95	178	182	70	M 12	20	6,26
SZ 18-100	-	16340501	18x105	95	-	212	100	M 12	10	3,55
SZ 24-0	14505501	16505501	24x130	120	130	137	0	M 16	10	4,11
SZ 24-20	14515501	16515501	24x130	120	150	157	20	M 16	10	4,71
SZ 24-50	14525501	16525501	24x130	120	180	187	50	M 16	10	5,58
SZ 24-100	-	16530501	24x130	120	-	237	100	M 16	5	3,49

Description	Ref. No.	Drill hole Øxdepth	Setting-depth	Anchor-length l	Fixture thickness t _{fix}	Thread	Pkg. cont.	Weight per pkg.
SZ-SK 12-10	14111531	12 x 80	70	80	10	M 8	50	3,01
SZ-SK 12-25	14121531	12 x 80	70	95	25	M 8	50	3,65
SZ-SK 12-50	14131531	12 x 80	70	120	50	M 8	25	2,33
SZ-SK 15-15	14216531	15 x 95	85	100	15	M 10	25	3,07
SZ-SK 15-25	14221531	15 x 95	85	110	25	M 10	25	3,29
SZ-SK 15-35	14226531	15 x 95	85	120	35	M 10	25	3,55
SZ-SK 15-50	14231531	15 x 95	85	135	50	M 10	25	3,96
SZ-SK 18-20	14316531	18 x 105	95	115	20	M 12	20	3,99
SZ-SK 18-40	14326531	18 x 105	95	135	40	M 12	20	4,62

Other lengths and special assemblies on demand.

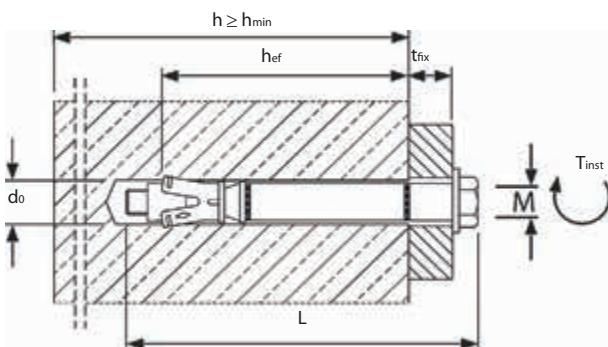


Extract from Permissible Service Conditions of ETA-02/0030

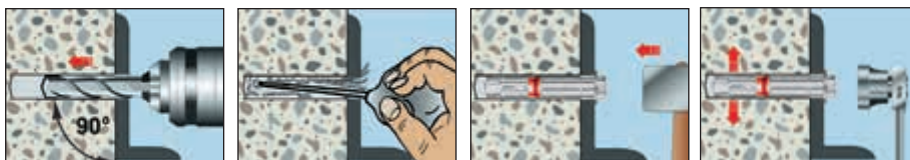
Approved loads for single anchor without influence of spacing and edge distance.
Total safety factor as per ETAG 001 included (γ_M and γ_P).

Loads and performance data		Highload Anchor SZ A4		SZ 12 M 8	SZ 15 M 10	SZ 18 M 12	SZ 24 M 16
cracked concrete							
Mean ultimate loads, tension		C25/30 N_{um}	[kN]	19,8	31,6	37,2	68,8
Mean ultimate loads, shear		C25/30 V_{um}	[kN]	32,4	47,9	72,9	111,1
Approved loads, tension		C20/25 appr. N	[kN]	4,3	7,6	12,3	17,1
		C25/30 appr. N	[kN]	4,7	8,4	13,5	18,9
		C30/37 appr. N	[kN]	5,2	9,3	15,0	20,9
		C40/50 appr. N	[kN]	6,0	10,7	17,3	24,2
		C50/60 appr. N	[kN]	6,6	11,8	19,0	26,6
non-cracked concrete							
Approved loads, tension	SZ-S, SZ-SK / SZ-B	C20/25 appr. N	[kN]	7,6	11,9	16,7	24,0
		C25/30 appr. N	[kN]	8,4	13,1	18,3	26,4
		C30/37 appr. N	[kN]	9,3	14,5	20,3	29,3
		C40/50 appr. N	[kN]	9,9 / 10,7	15,7 / 16,8	22,9 / 23,5	33,8
		C50/60 appr. N	[kN]	9,9 / 11,8	15,7 / 18,5	22,9 / 25,8	37,2
cracked concrete							
Approved loads, shear	SZ-S, SZ-SK	C20/25 appr. V	[kN]	12,6	19,4	24,5	34,3
		\geq C25/30 appr. V	[kN]	12,6	19,4	27,0	37,7
Approved loads, shear	SZ-B	C20/25 appr. V	[kN]	13,7	20,5	24,5	34,3
		\geq C25/30 appr. V	[kN]	13,7	21,1	27,0	37,7
non-cracked concrete							
Approved loads, shear	SZ-S, SZ-SK	C20/25 appr. V	[kN]	12,6	19,4	32,6	48,0
		\geq C25/30 appr. V	[kN]	12,6	19,4	32,6	48,3
Approved loads, shear	SZ-B	C20/25 appr. V	[kN]	13,7	21,1	34,3	48,0
		\geq C25/30 appr. V	[kN]	13,7	21,1	35,4	52,6
cracked concrete / non-cracked concrete							
Approved bending moments	SZ-S, SZ-SK / SZ-B	appr. M	[Nm]	11,9 / 14,9	23,8 / 29,7	42,1 / 52,6	106,2 / 132,6
Spacing and edge distance							
Effective anchorage depth		h_{ef}	[mm]	60	71	80	100
Characteristic spacing		$s_{cr,N}$	[mm]	180	213	240	300
Characteristic edge distance		$c_{cr,N}$	[mm]	90	106,5	120	150
Minimum spacing / for edge distance c		s_{min} / c	[mm]	70/100	85/130	100/170	180/180
Minimum edge distance / for spacing s		c_{min} / s	[mm]	75/135	85/185	100/210	180/180
Minimum thickness of concrete slab		h_{min}	[mm]	120	140	160	200
Installation parameters							
Drill hole diameter		d_o	[mm]	12	15	18	24
Diameter of clearance hole in the fixture		$\leq d_f$	[mm]	14	17	20	26
Depth of drill hole		h_1	[mm]	80	95	105	130
Installation torque SZ-S / SZ-SK / SZ-B		T_{inst}	[Nm]	30/17,5/35	50/42,5/55	80/50/90	170/-/170
Width across nut SZ-S / SZ-B		SW	[mm]	13	17	19	24
Internal hexagon size SZ-SK		SW _{Hex}	[mm]	5	6	8	-
Minimum thickness of fixture for SZ-SK		$t_{fix} \geq$	[mm]	10	14	18	-

For anchor designing, an easy to operate CD-ROM is available on request or can be downloaded at www.mkt.de.



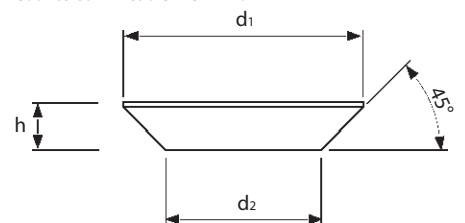
Installation



Dimensions countersunk head SZ-SK A4 [mm]

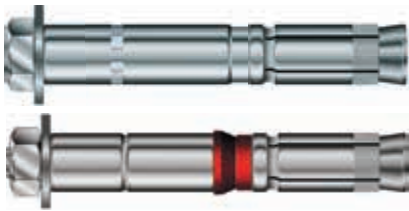
	d1	d2	h
SZ-SK 12 M 8	20,5	11,5	5,0
SZ-SK 15 M 10	24,5	14,5	5,7
SZ-SK 18 M 12	29,5	17,5	6,7

Countersunk head SZ-SK A4.



Highload Anchor SL

Steel, zinc plated / Stainless steel A4/316



Highload Anchor SL

Highload Anchor SL A4



Description

The Highload Anchor SL is a torque controlled sleeve anchor for through fastenings in non-cracked concrete. Three versions are available: SL-S with hexagon head screw, SL-B with hexagon nut and SL-SK with countersunk head screw. New: European technical approval, Option 7 for anchor size M10 steel galvanized. German approval in concrete strength class C12/15.

Applications

Medium to heavy duty anchorings of base plates, supports, pallet racks, brackets, railings in non-cracked concrete.



Range of loading: 5,4 kN - 66,8 kN

Range of concrete quality: C12/15 - C50/60



M10 zinc plated



M10 zinc plated



Highload Anchor SL A4¹⁾



SL-B SL-S

→ Stainless steel A4/316

→ For non-cracked concrete

Description	Type SL-S	Type SL-B	Drill hole Øxdepth	Setting- depth	Anchor- length			Fixture- thickness	Thread	Pkg. cont.	Weight per pkg.
	Ref. No.	Ref. No.			mm	Typ S mm	Typ B mm				
SL 10-10 A4	10010501	12010501	10x60	53	69	69	10	M 6	50	1,73	
SL 10-25 A4	10020501	12020501	10x60	53	84	84	25	M 6	50	2,15	
SL 10-50 A4	10025501	12025501	10x60	53	104	106	50	M 6	50	2,69	
SL 14-10 A4	10210501	12210501	14x85	73	94	96	10	M 10	25	2,60	
SL 14-25 A4	10220501	12220501	14x85	73	109	111	25	M 10	25	3,02	
SL 14-50 A4	10225501	12225501	14x85	73	134	136	50	M 10	25	3,68	
SL 28-30 A4	10610501	12610501	28x150	135	182	188	30	M 20	5	4,30	
SL 28-60 A4	10615501	12615501	28x150	135	212	218	60	M 20	5	5,02	

Other length and special assemblies on demand.

¹⁾ Not part of approvals.

Highload Anchor SL



SL-B SL-S

→ Steel, zinc plated

→ For non-cracked concrete

Description	Type SL-S	Type SL-B	Drill hole Øxdepth	Setting- depth	Anchor- length			Fixture- thickness	Thread	Pkg. cont.	Weight per pkg.
	Ref. No.	Ref. No.			mm	Typ S mm	Typ B mm				
SL 14-0	10205101	12205101	14x85	73	84	86	0	M10	25	2,38	
SL 14-10	10210101	12210101	14x85	73	94	96	10	M10	25	2,71	
SL 14-25	10220101	12220101	14x85	73	109	111	25	M10	25	3,08	
SL 14-50	10225101	12225101	14x85	73	134	136	50	M10	25	3,73	
SL 14-75	10230101	12230101	14x85	73	159	161	75	M10	25	4,43	
SL 14-100	10235101	12235101	14x85	73	179	181	100	M10	25	5,18	
SL 14-125	-	12240101	14x85	73	-	210	125	M10	25	5,32	
SL 14-160	-	12245101	14x85	73	-	245	160	M10	20	4,96	

Other length and special assemblies on demand.

Highload Anchor SL-SK A4¹⁾



SL-SK

→ Stainless steel A4/316

→ For non-cracked concrete

Description	Type SL-SK	Drill hole Øxdepth	Setting- depth	Anchor- length	Fixture- thickness	Thread	Pkg. cont.	Weight per pkg.
	Ref. No.	mm	mm	mm	t _{fix} mm		pcs.	kg
SL 10-25 A4	10020531	10x60	53	86	31	M 6	50	2,32

Other length and special assemblies on demand.

¹⁾ Not part of approvals.



Extract from Permissible Service Conditions of ETA-08/0230 and Z-21.1-1638.

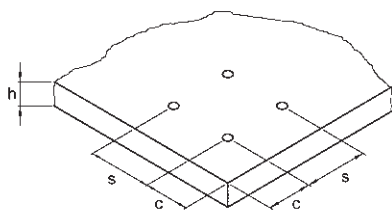
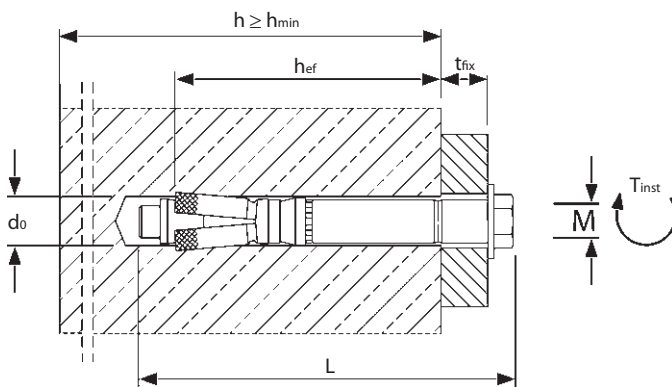
Approved loads for single anchor without influence of spacing and edge distance.
Total safety factor as per ETAG 001 included (γ_M and γ_F).

Recommended loads for single anchor without influence of spacing and edge distance.
Total safety factor as per ETAG 001 included (γ_M and γ_F).

Loads and performance data	Highload Anchor SL SL		SL 14	SL 10 ¹⁾	SL 14 ¹⁾	SL 28 ¹⁾
			M 10	M 6	M 10	M 20
			steel, zinc pltd.	A4-70	A4-70	A4-70
approved values - non-cracked concrete						
Mean ultimate loads, tension	C25/30 N _{um}	[kN]	43,3	15,9	40,8	160,8
	C25/30 N _{um}	[kN]	35,6	20,8	45,3	208,7
Loads, tension	C12/15 N	[kN]	7,6	-	-	-
	C20/25 N	[kN]	9,5	5,4	12,6	33,5
	C30/37 N	[kN]	11,6	5,4	13,8	36,9
	C40/50 N	[kN]	13,4	5,4	15,5	47,3
	C50/60 N	[kN]	14,8	5,4	15,5	52,0
Loads, shear	C12/15 V	[kN]	13,3	-	-	-
	≥ C20/25 V	[kN]	13,3	6,7	14,5	66,8
Bending moments	M	[Nm]	34,3	4,9	23,9	208,1
Spacing and edge distance						
Effective anchorage depth	h _{ef}	[mm]	65	45	65	125
Characteristic spacing	s _{cr,N}	[mm]	195	135	195	375
Characteristic edge distance	c _{cr,N}	[mm]	97,5	67,5	97,5	187,5
Minimum spacing	s _{min}	[mm]	60	70	100	190
Minimum edge distance	c _{min}	[mm]	120	90	130	250
Minimum thickness of concrete slab	h _{min}	[mm]	130	130	200	350
Installation parameters						
Drill hole diameter	d _o	[mm]	14	10	14	28
Diameter of clearance hole in the fixture	d _f	[mm]	16	12	16	31
Depth of drill hole	h ₁	[mm]	85	60	85	150
Installation torque	T _{inst}	[Nm]	50	10	50	400
Width across nut	SW	[mm]	17	10	17	30

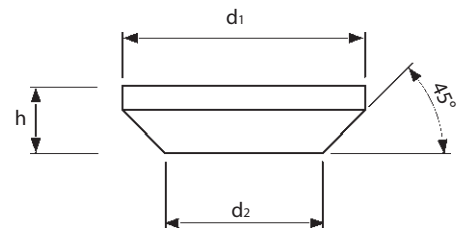
For anchor designing an easy to operate CD-ROM is available on request or can be downloaded at www.mkt.de.

¹⁾ Not part of approvals.

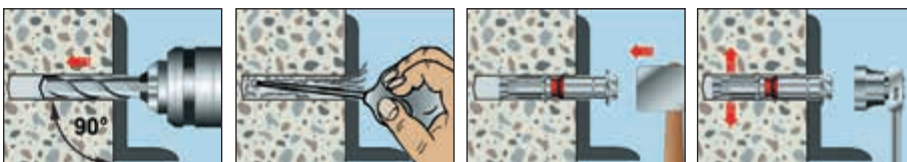


Dimensions countersunk head SL-SK [mm]			
	d1	d2	h
SL-SK 10 M 6	20,0	11,0	6,0

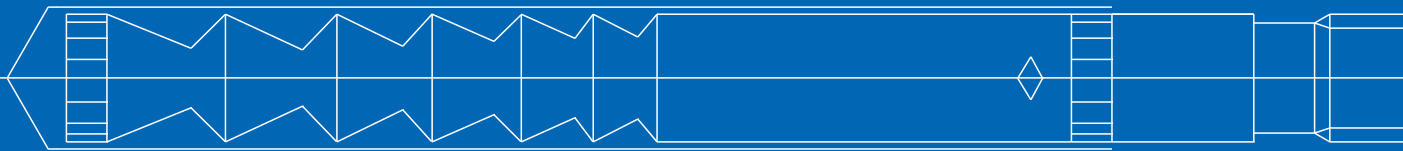
Countersunk head version SL-SK.

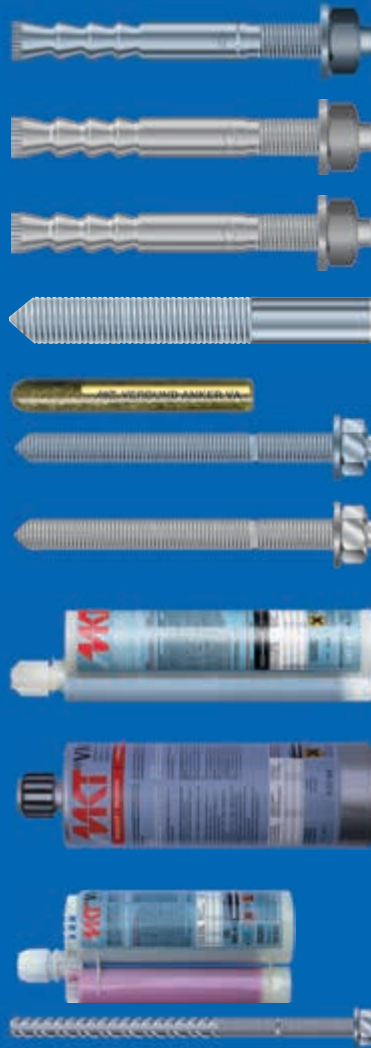
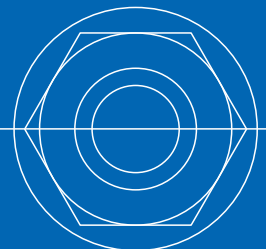
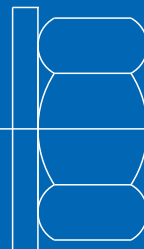
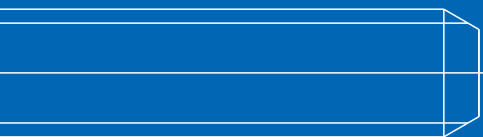


Installation



Chemical Anchors





Mechanical Heavy Duty Anchors

Chemical Anchors

Light Duty Anchors

Service

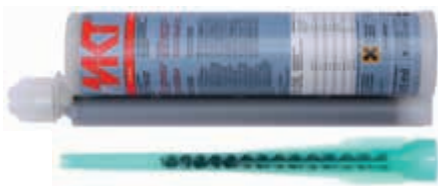
Injection System VMZ



Threaded Stud VMZ-A



Cartridge VMZ 150
for silicone guns
Content: 150ml



Cartridge VMZ 345
Side-by-side Cartridge
Content: 345ml



Cartridge VMZ 410
Coaxial Cartridge
Content: 410ml



- Range of loading:** 4,3 kN - 105,7 kN
Range of concrete quality: C20/25 - C50/60
Material: Steel, zinc plated, Stainless steel A4, Stainless steel HCR
on demand: hot dip galvanized

Description

The Injection System VMZ consists of an anchor rod with conical expansion elements and a 2 component injection adhesive. This combination provides extremely high load bearing capacity even at minimum edge distance and spacing. The VMZ system combines the benefits of bonded anchors and expansion anchors in a European technical approved fastening system for both cracked and non-cracked concrete.

Advantages:

- small thickness of concrete slab
- no load reduction for wet or water-filled (M12 and larger) drill holes
- approved from -5 °C to +40°C temperature of base material while installing
- through fastening installation possible for M10 and bigger (no additional accessories required)
- VMZ 75 M 12: drill hole like M10 but connection thread M12 (ideally suited for through fastening installation)
- sealed drill hole
- with fire approval (loads see page 105)
- large variety of different diameters, anchorage depths and lengths – very economic fixings, optimized to the requirements of the fixing
- opened cartridges can be re-used with a new mixer nozzle

Applications:

Heavy duty fastenings in cracked and non-cracked concrete, e.g. steel beams, steel supports, railings, brackets, facade substructures, cable trays, fixing of bridge railings according to GEL 14 (VMZ 70 M12-40/130 A4); with through-setting installation VMZ 75 M12-40/135 A4) and GEL 33 (VMZ 90 M16-60/175 A4).

Injection Cartridge VMZ



- Two component cartridge, styrene-free
- Various cartridge systems
- Approved for cracked and non-cracked concrete

Description	Ref. No.	Content	Content of master box	Weight per master box	Weight per piece
		ml	pcs.	kg	kg
Cartridge VMZ 150	28999301	150	12	4,32	0,36
Cartridge VMZ 345	28255310	345	12	8,28	0,69
Cartridge VMZ 410	28254701	410	12	9,84	0,82
Static mixer VM-X	28305111	-	12	0,12	0,01
Mixer extension VM-XE (200mm)	28306011	-	12	-	0,01
Installation wedge VMZ-MK	33300103	-	10	-	0,01

One static mixer VM-X as well as one screw-on cap comes with each cartridge.

Threaded Stud VMZ-A
Steel, zinc plated



- ➔ May be used in structures subject to dry internal conditions
- ➔ Version LG: with thread to concrete surface
- ➔ Drill hole depth from 42mm



Description	Ref. No.	Drill hole Øxdepth mm	Set-ting depth mm	Fixture thick-ness mm	Anchor-length mm	Thread mm	Pkg. cont. pcs.	Weight per pkg. kg
VMZ-A 40 M8-15/65	32115101	10x42	41	15	65	M8x22	10	0,30
VMZ-A 50 M8-15/80	32120101	10x55	52	15	80	M8x22	10	0,36
VMZ-A 50 M8-30/95	32135101	10x55	52	30	95	M8x31	10	0,41
VMZ-A 50 M8-45/110	32145101	10x55	52	45	110	M8x31	10	0,47
VMZ-A 60 M10-10/85	32205101	12x65	63	10	85	M10x18	10	0,61
VMZ-A 60 M10-20/95	32220101	12x65	63	20	95	M10x27	10	0,66
VMZ-A 60 M10-30/105	32225101	12x65	63	30	105	M10x27	10	0,72
VMZ-A 60 M10-60/135	32235101	12x65	63	60	135	M10x47	10	0,87
VMZ-A 60 M10-100/175	32245101	12x65	63	100	175	M10x57	10	1,10
VMZ-A 75 M10-20/110	32255101	12x80	78	20	110	M10x27	10	0,75
VMZ-A 75 M12-25/120	32323171	12x80	78	25	120	M12x37	10	0,85
VMZ-A 75 M12-40/135	32324171	12x80	78	40	135	M12x52	10	0,95
VMZ-A 75 M12-60/155	32333101	12x80	78	60	155	M12x72	10	1,05
VMZ-A 75 M12-80/175	32336101	12x80	78	80	175	M12x92	10	1,20
VMZ-A 70 M12-25/115	32323101	14x75	74	25	115	M12x36	10	1,20
VMZ-A 80 M12-10/110	32305101	14x85	84	10	110	M12x21	10	1,17
VMZ-A 80 M12-25/125	32325101	14x85	84	25	125	M12x36	10	1,28
VMZ-A 80 M12-50/150	32330101	14x85	84	50	150	M12x46	10	1,49
VMZ-A 80 M12-100/200	32345101	14x85	84	100	200	M12x71	10	1,93
VMZ-A 80 M12-125/225	32355101	14x85	84	125	225	M12x71	10	2,17
VMZ-A 80 M12-165/265	32365101	14x85	84	165	265	M12x71	10	2,57
VMZ-A 95 M12-25/140	32327101	14x100	99	25	140	M12x36	10	1,40
VMZ-A 100 M12-25/145	32375101	14x105	104	25	145	M12x36	10	1,46
VMZ-A 100 M12-60/180	32385101	14x105	104	60	180	M12x56	10	1,75
VMZ-A 100 M12-100/220	32390101	14x105	104	100	220	M12x61	10	2,12
VMZ-A 110 M12-25/155	32377101	14x115	114	25	155	M12x36	10	1,55
VMZ-A 125 M12-25/170	32379101	14x130	129	25	170	M12x36	10	1,75
VMZ-A 90 M16-30/145	32555101	18 x 98	94	30	145	M16x44	10	2,20
VMZ-A 105 M16-30/160	32550101	18x113	109	30	160	M16x44	10	2,45
VMZ-A 125 M16-30/180	32515101	18x133	130	30	180	M16x44	10	2,78
VMZ-A 125 M16-60/210	32520101	18x133	130	60	210	M16x55	10	3,60
VMZ-A 125 M16-100/250	32530101	18x133	130	100	250	M16x65	10	4,23
VMZ-A 125 M16-165/315	32540101	18x133	130	165	315	M16x90	10	5,25
VMZ-A 145 M16-30/200	32560101	18x153	150	30	200	M16x44	10	3,70
VMZ-A 115 M20-30/175	32608101	22x120	120	30	175	M20x46	5	2,40
VMZ-A 170 M20-20/225 LG	32603101	24x180	180	20	225	M20x41	5	3,40
VMZ-A 170 M20-25/230	32605101	24x180	180	25	230	M20x33	5	3,52
VMZ-A 170 M20-50/255	32610101	24x180	180	50	255	M20x46	5	3,83
VMZ-A 170 M20-100/305	32620101	24x180	180	100	305	M20x71	5	4,46
VMZ-A 190 M20-50/275	32612101	24x200	200	50	275	M20x46	5	4,20
VMZ-A 170 M24-50/260	32705101	26x185	182	50	260	M24x50	5	4,58
VMZ-A 170 M24-100/310	32715101	26x185	182	100	310	M24x75	5	5,46
VMZ-A 200 M24-50/290 LG	32711101	26x215	212	50	290	M24x75	5	5,11
VMZ-A 200 M24-50/290	32710101	26x215	212	50	290	M24x50	5	5,11
VMZ-A 200 M24-100/340	32720101	26x215	212	100	340	M24x75	5	6,01
VMZ-A 225 M24-50/315	32712101	26x240	237	50	315	M24x50	5	5,73

Other lengths or threads on demand.

Dispenser and accessories for drill hole cleaning see page 49.

Threaded Stud VMZ-A A4
Stainless steel A4 / 316



- ➔ May be used in structures subject to dry internal conditions or external atmospheric exposure
- ➔ Version LG: with thread to concrete surface
- ➔ Drill hole depth from 42mm



Description	Ref. No.	Drill hole Øxdepth mm	Set-ting depth mm	Fixture thick-ness mm	Anchor-length mm	Thread mm	Pkg. cont. pcs.	Weight per pkg. kg
VMZ-A 40 M8-15/65 A4	32115501	10x42	41	15	65	M8x22	10	0,30
VMZ-A 50 M8-15/80 A4	32120501	10x55	52	15	80	M8x22	10	0,36
VMZ-A 50 M8-30/95 A4	32135501	10x55	52	30	95	M8x31	10	0,41
VMZ-A 50 M8-45/110 A4	32145501	10x55	52	45	110	M8x31	10	0,47
VMZ-A 60 M10-10/85 A4	32205501	12x65	63	10	85	M10x18	10	0,61
VMZ-A 60 M10-20/95 A4	32220501	12x65	63	20	95	M10x27	10	0,66
VMZ-A 60 M10-30/105 A4	32225501	12x65	63	30	105	M10x27	10	0,72
VMZ-A 60 M10-60/135 A4	32235501	12x65	63	60	135	M10x47	10	0,87
VMZ-A 60 M10-100/175 A4	32245501	12x65	63	100	175	M10x57	10	1,10
VMZ-A 75 M10-20/110 A4	32255501	12x80	78	20	110	M10x27	10	0,75
VMZ-A 75 M10-40/130 A4	32265501	12x80	78	40	130	M10x47	10	0,86
VMZ-A 75 M12-25/120 A4	32323571	12x80	78	25	120	M12x37	10	0,85
VMZ-A 75 M12-40/135 A4	32324571	12x80	78	40	135	M12x52	10	0,95
VMZ-A 75 M12-60/155 A4	32333501	12x80	78	60	155	M12x72	10	1,05
VMZ-A 75 M12-80/175 A4	32336501	12x80	78	80	175	M12x92	10	1,20
VMZ-A 70 M12-25/115 A4	32323501	14x75	74	25	115	M12x36	10	1,20
VMZ-A 80 M12-10/110 A4	32305501	14x85	84	10	110	M12x21	10	1,17
VMZ-A 80 M12-25/125 A4	32325501	14x85	84	25	125	M12x36	10	1,28
VMZ-A 80 M12-50/150 A4	32330501	14x85	84	50	150	M12x46	10	1,49
VMZ-A 80 M12-100/200 A4	32345501	14x85	84	100	200	M12x71	10	1,93
VMZ-A 80 M12-125/225 A4	32355501	14x85	84	125	225	M12x71	10	2,17
VMZ-A 80 M12-165/265 A4	32365501	14x85	84	165	265	M12x71	10	2,57
VMZ-A 95 M12-25/140 A4	32327501	14x100	99	25	140	M12x36	10	1,40
VMZ-A 100 M12-25/145 A4	32375501	14x105	104	25	145	M12x36	10	1,46
VMZ-A 100 M12-60/180 A4	32385501	14x105	104	60	180	M12x56	10	1,75
VMZ-A 100 M12-100/220 A4	32390501	14x105	104	100	220	M12x61	10	2,12
VMZ-A 110 M12-25/155 A4	32377501	14x115	114	25	155	M12x36	10	1,55
VMZ-A 125 M12-25/170 A4	32379501	14x130	129	25	170	M12x36	10	1,75
VMZ-A 90 M16-30/145 A4	32555501	18x98	94	30	145	M16x44	10	2,20
VMZ-A 90 M16-45/160 A4	32558501	18x98	94	45	160	M16x59	10	2,78
VMZ-A 90 M16-60/175 A4	32559501	18 x 98	94	60	175	M16x74	10	3,08
VMZ-A 105 M16-30/160 A4	32550501	18x113	109	30	160	M16x44	10	2,45
VMZ-A 125 M16-30/180 A4	32515501	18x133	130	30	180	M16x44	10	2,78
VMZ-A 125 M16-60/210 A4	32520501	18x133	130	60	210	M16x55	10	3,60
VMZ-A 125 M16-100/250 A4	32530501	18x133	130	100	250	M16x65	10	4,23
VMZ-A 125 M16-165/315 A4	32540501	18x133	130	165	315	M16x90	10	5,25
VMZ-A 145 M16-30/200 A4	32560501	18x153	150	30	200	M16x44	10	3,70
VMZ-A 115 M20-30/175 A4	32608501	22x120	120	30	175	M20x46	5	2,40
VMZ-A 170 M20-20/225 LG A4	32603501	24x180	180	20	225	M20x41	5	3,40
VMZ-A 170 M20-25/230 A4	32605501	24x180	180	25	230	M20x33	5	3,52
VMZ-A 170 M20-50/255 A4	32610501	24x180	180	50	255	M20x46	5	3,83
VMZ-A 170 M20-100/305 A4	32620501	24x180	180	100	305	M20x71	5	4,46
VMZ-A 190 M20-50/275 A4	32612501	24x200	200	50	275	M20x46	5	4,20
VMZ-A 170 M24-50/260 A4	32705501	26x185	182	50	260	M24x50	5	4,58
VMZ-A 170 M24-100/310 A4	32715501	26x185	182	100	310	M24x75	5	5,46
VMZ-A 200 M24-50/290 LG A4	32711501	26x215	212	50	290	M24x75	5	5,11
VMZ-A 200 M24-50/290 A4	32710501	26x215	212	50	290	M24x50	5	5,11
VMZ-A 200 M24-100/340 A4	32720501	26x215	212	100	340	M24x75	5	6,01
VMZ-A 225 M24-50/315 A4	32712501	26x240	237	50	315	M24x50	5	5,73

Other lengths or threads on demand.

Chemical Anchors

Threaded Stud VMZ-A HCR

Stainless steel HCR

→ For use in particularly corrosive environments

→ High Corrosion Resistant Steel grade 1.4529

→ Version LG: with thread to concrete surface



Description	Ref. No.	Drill hole Øxdepth mm	Set- ting depth mm	Fixture thick- ness mm	Anchor- length mm	Thread mm	Pkg. cont. pcs.	Weight per pkg. kg
VMZ-A 50 M8-15/80 HCR	32120651	10x55	52	15	80	M8x22	10	0,36
VMZ-A 50 M8-30/95 HCR	32135651	10x55	52	30	95	M8x31	10	0,41
VMZ-A 50 M8-45/110 HCR	32145651	10x55	52	45	110	M8x31	10	0,47
VMZ-A 60 M10-10/85 HCR	32205651	12x65	63	10	85	M10x18	10	0,61
VMZ-A 60 M10-20/95 HCR	32220651	12x65	63	20	95	M10x27	10	0,66
VMZ-A 60 M10-30/105 HCR	32225651	12x65	63	30	105	M10x27	10	0,72
VMZ-A 60 M10-60/135 HCR	32235651	12x65	63	60	135	M10x47	10	0,87
VMZ-A 60 M10-100/175 HCR	32245651	12x65	63	100	175	M10x57	10	1,10
VMZ-A 80 M12-10/110 HCR	32305651	14x85	84	10	110	M12x21	10	1,17
VMZ-A 80 M12-25/125 HCR	32325651	14x85	84	25	125	M12x36	10	1,28
VMZ-A 80 M12-50/150 HCR	32330651	14x85	84	50	150	M12x46	10	1,49
VMZ-A 80 M12-100/200 HCR	32345651	14x85	84	100	200	M12x71	10	1,93
VMZ-A 80 M12-125/225 HCR	32355651	14x85	84	125	225	M12x71	10	2,17
VMZ-A 80 M12-165/265 HCR	32365651	14x85	84	165	265	M12x71	10	2,57
VMZ-A 100 M12-25/145 HCR	32375651	14x105	104	25	145	M12x36	10	1,46
VMZ-A 100 M12-60/180 HCR	32385651	14x105	104	60	180	M12x56	10	1,75
VMZ-A 100 M12-100/220 HCR	32390651	14x105	104	100	220	M12x61	10	2,12
VMZ-A 125 M16-30/180 HCR	32515651	18x133	130	30	180	M16x44	10	2,78
VMZ-A 125 M16-60/210 HCR	32520651	18x133	130	60	210	M16x55	10	3,60
VMZ-A 125 M16-100/250 HCR	32530651	18x133	130	100	250	M16x65	10	4,23
VMZ-A 125 M16-165/315 HCR	32540651	18x133	130	165	315	M16x90	10	5,25
VMZ-A 170 M20-20/225 LG HCR	32603651	24x180	180	20	225	M20x41	5	3,40
VMZ-A 170 M20-25/230 HCR	32605651	24x180	180	25	230	M20x33	5	3,52
VMZ-A 170 M20-50/255 HCR	32610651	24x180	180	50	255	M20x46	5	3,83
VMZ-A 170 M20-100/305 HCR	32620651	24x180	180	100	305	M20x71	5	4,46
VMZ-A 200 M24-50/290 LG HCR	32705651	26x215	215	50	290	M24x75	5	5,11
VMZ-A 200 M24-50/290 HCR	32710651	26x215	215	50	290	M24x50	5	5,11
VMZ-A 200 M24-100/340 HCR	32720651	26x215	215	100	340	M24x75	5	6,01

Other lengths or threads on demand.

Curing Time Injection Adhesive VMZ

→ Cartridge temperature when installing min. +5°C

Temperature (°C) of the base material	Gel time	Curing time	
		dry concrete	wet concrete
-5°C	1:30 h	6:00 h	12:00 h
0°C	45 min	3:00 h	6:00 h
+5°C	20 min	2:00 h	4:00 h
+10°C	12 min	1:20 h	2:40 h
+20°C	6 min	45 min	1:30 h
+30°C	4 min	25 min	50 min
+35°C	2 min	20 min	40 min
+40°C	1,4 min	15 min	30 min

Cleaning Brush RB M6



RB M6, with connection thread M6



RBL M6, with internal and external thread M6



RBL M6 SDS, with internal thread M6

- With connection thread M6 – extension for large depths of drill hole and/or for through-setting installation
- For drilling machines with keyed chuck or with SDS adaptor for SDS plus drills

Description	Ref. No.	Suitable for drill hole Ø mm	Total length of brush mm	Suitable for			Pkg. cont. pcs.	Weight per piece kg
				VMZ-A	VMZ-A dyn	VMZ-IG		
RB 10 M6	33510101	10	130	M8	-	M6	1	0,05
RB 12 M6	33512101	12	140	M10, 75 M12	-	M8	1	0,05
RB 14 M6	33514101	14	180	M12	M12	M10	1	0,05
RB 18 M6	33518101	18	200	M16	M16	M12	1	0,05
RB 22 M6	33522101	22	220	115 M20	-	115 M16	1	0,05
RB 24 M6	33524101	24	250	M20	M20	M16	1	0,06
RB 26 M6	33526101	26	290	M24	-	M20	1	0,06
RBL M6	33968101	Brush extension 150mm with connection thread M6					1	0,09
RBL M6 SDS	33350101	SDS Plus adapter with internal thread M6					1	0,06

Blow-out pump VM-AP



- Drill hole cleaning for VMZ-A M8-M16, VMZ-A dyn M12-M16 and VMZ-IG M6-M12

Description	Ref. No.	Max. depth of drill hole or max. depth of drill hole with fixture (through fastening) mm	Pkg. cont. pcs.	Weight per piece kg
VM-AP 360, blow-out pump	33200101	300	1	0,27

Air gun VM-ABP



- Drill hole cleaning with compressed air for VMZ-A M20-M24, VMZ-A dyn M20 and VMZ-IG M16-M20

Description	Ref. No.	Max. depth of drill hole or max. depth of drill hole with fixture (through fastening) mm	Pkg. cont. pcs.	Weight per piece kg
VM-ABP 250	33100101	240	1	1,00
VM-ABP 500	33106101	480	1	1,30

Dispenser VM-P Profi



- Professional dispenser with an ideal center of gravity for more comfortable working
- Automatic pressure release for minimum material overrun

Description	Ref. No.	Suitable for cartridge	Pkg. cont. pcs.	Weight per piece kg
VM-P 345 Profi	28350511	150ml, 280ml, 300ml, 345ml also suitable for silicone cartridges	1	1,00
VM-P 380 Profi	28351001	380ml, 410ml, 420ml	1	1,10

Dispenser VM-P Standard



- For occasional use, metal version
- Piston rod with adjusting screw

Description	Ref. No.	Suitable for cartridge	Pkg. cont. pcs.	Weight per piece kg
VM-P 345 Standard	28350505	150ml, 280ml, 300ml, 345ml also suitable for silicone cartridges	1	1,00
VM-P 380 Standard	28353005	380ml, 410ml, 420ml	1	1,15

Dispenser VM-P Pneumatic



- Professional air tool with an optimum center of gravity and quick cartridge exchange
- Automatic pressure release system reduces material overrun to a minimum
- Single-hand pressure regulation to adjust the piston speed

Description	Ref. No.	Suitable for cartridge	max. working pressure 8bar, 40l/min	Pkg. cont. pcs.	Weight per piece kg
VM-P 345 Pneumatic	28350601	345ml	1	2,41	
VM-P 380 Pneumatic	28352002	380ml, 410ml, 420ml	1	2,00	

Chemical Anchors



Extract from Permissible Service Conditions of ETA-04/0092 (M 8 - M 12)

Approved loads for single anchor without influence of spacing and edge distance for temperature range -40°C to +80°C⁵⁾ (Approved loads for temperature range -40°C to +120°C see ETA-04/0092). Total safety factor as per ETAG 001 included (γ_M and γ_P).

Loads and performance **Injection System VMZ, steel zinc plated M8-M12**
data

		40 M8	50 M8	60 M10	75 M10	75 M12	70 M12	80 M12	95 M12	100 M12	110 M12	125 M12
cracked concrete												
Mean ultimate loads, tension	C25/30 N _{um}	[kN]	12,3	19,5	28,0	29,5	29,5	41,0	48,2	67,2	67,2	67,2
Mean ultimate loads, shear	C25/30 V _{um}	[kN]	14,6	14,6	23,2	23,2	33,7	33,7	33,7	33,7	33,7	33,7
Approved loads, tension	C20/25 appr. N	[kN]	4,3	6,1	8,0	11,1	11,1	10,0	12,3	15,9	17,1	19,8
	C25/30 appr. N	[kN]	4,8	6,7	8,8	11,9	12,2	11,0	13,5	17,5	18,9	21,8
	C30/37 appr. N	[kN]	5,3	7,4	9,7	11,9	13,6	12,2	15,0	19,4	20,9	24,1
	C40/50 appr. N	[kN]	6,1	8,5	11,2	11,9	15,7	14,2	17,3	22,4	24,2	27,1
	C50/60 appr. N	[kN]	6,7	8,6	11,9	11,9	16,7	15,6	19,0	24,6	26,6	27,1
non-cracked concrete												
Approved loads, tension	C20/25 appr. N	[kN]	4,3	8,5	11,2	11,9	15,6	14,1	17,2	19,0	24,0	23,8
	C25/30 appr. N	[kN]	4,7	8,6	11,9	11,9	16,7	15,5	18,9	21,0	26,4	26,2
	C30/37 appr. N	[kN]	5,2	8,6	11,9	11,9	16,7	17,1	21,0	23,2	27,1	27,1
	C40/50 appr. N	[kN]	6,0	8,6	11,9	11,9	16,7	19,8	24,2	25,7	27,1	27,1
	C50/60 appr. N	[kN]	6,6	8,6	11,9	11,9	16,7	21,8	25,7	27,1	27,1	27,1
cracked and non-cracked concrete												
Approved loads, shear	≥ C20/25 appr. V	[kN]	8,0	8,0	12,0	12,0	19,4	19,4	19,4	19,4	19,4	19,4
Approved loads, shear Type LG	≥ C20/25 appr. V	[kN]	8,0	8,0	12,0	12,0	19,4	19,4	19,4	19,4	19,4	19,4
Approved bending moments	appr. M	[Nm]	17,1	17,1	34,3	34,3	60,0	60,0	60,0	60,0	60,0	60,0

Spacing and edge distance

Effective anchorage depth	h_{ef}	[mm]	40	50	60	75	75	70	80	95	100	110	125
Characteristic spacing	$s_{cr,N}$	[mm]	120	150	180	225	225	210	240	285	300	330	375
Characteristic edge distance	$c_{cr,N}$	[mm]	60	75	90	112,5	112,5	105	120	142,5	150	165	187,5
cracked concrete													
Minimum thickness of concrete slab	≥ h_{min}	[mm]	80	80	100	110	110	110	110	130	130	140	160
Minimum spacing	s_{min}	[mm]	40	40	40	40	50	55	40	40	50	50	50
Minimum edge distance	c_{min}	[mm]	40	40	40	40	50	55	50	50	50	50	50
non-cracked concrete													
Minimum thickness of concrete slab	≥ h_{min}	[mm]	80	80	100	110	110	110	110	130	130	140	160
Minimum spacing	s_{min}	[mm]	40	40	50	50	50	55	55	55	80 ¹⁾	80 ¹⁾	80 ¹⁾
Minimum edge distance	c_{min}	[mm]	40	40	50	50	50	55	55	55	55 ¹⁾	55 ¹⁾	55 ¹⁾

Installation parameters

Drill hole diameter	d_o	[mm]	10	10	12	12	12	14	14	14	14	14	14
Diameter of clearance hole in the fixture Pre-installation	d_f	[mm]	9	9	12	12	14	14	14	14	14	14	14
Diameter of clearance hole in the fixture Through fastening ²⁾	d_f	[mm]	- ⁴⁾	- ⁴⁾	14	14	14	16	16	16	16	16	16
Depth of drill hole	h_o	[mm]	42	55	65	80	80	75	85	100	105	115	130
Installation torque	≤ T_{inst}	[Nm]	10	10	15	15	25	25	25	30	30	30	30
Width across nut	SW	[mm]	13	13	17	17	19	19	19	19	19	19	19
Amount of mortar per drill hole ³⁾		[ml]	3,4	4,1	6,1	7,0	7,0	6,8	8,6	9,0	9,2	9,4	9,6
Add. amount of mortar per drill hole for Through fastening per 10mm of fixture thickness 10mm		[ml]	-	-	1,0	1,0	0,7	1,2	1,2	1,2	1,2	1,2	1,2
Drill holes per cartridge ³⁾ VMZ 150		[Quan.]	31	26	18	15	15	16	12	12	11	11	11
Drill holes per cartridge ³⁾ VMZ 345 / VMZ 410		[Quan.]	88/108	73/90	49/60	43/52	43/52	44/54	34/43	33/41	32/40	32/39	31/38

¹⁾ For edge distance $c \geq 80$ mm, minimal spacing distance $s_{min} = 55$ mm

²⁾ The annular gap of the clearance hole must be completely filled with mortar after fixing.

³⁾ Values shown are for pre-installation. For through fastening additional mortar is required to completely fill the clearance hole in the fixture.

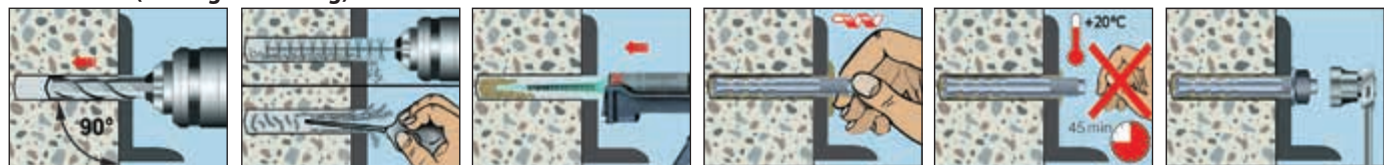
⁴⁾ Not for use in through fastening applications.

⁵⁾ max. long term temperature +50 °C / max. short term temperature +80 °C

Installation (Pre-installation)



Installation (Through fastening)





Extract from Permissible Service Conditions of ETA-04/0092 (M 16 - M 24)

Approved loads for single anchor without influence of spacing and edge distance for temperature range -40°C to +80°C⁴⁾ (Approved loads for temperature range -40°C to +120°C see ETA-04/0092). Total safety factor as per ETAG 001 included (γ_M and γ_P).

Loads and performance data

Injection System VMZ, steel zinc plated M16-M24

			90 M16	105 M16	125 M16	145 M16	115 M20	170 M20	190 M20	170 M24	200 M24	225 M24
								170 M20 LG	190 M20 LG	170 M24 LG	200 M24 LG	225 M24 LG
cracked concrete												
Mean ultimate loads, tension	C25/30 N _{um}	[kN]	49,0	74,8	108,7	108,7	103,3	149,6	149,6	146,2	200,9	200,9
Mean ultimate loads, shear	C25/30 V _{um}	[kN]	62,8	62,8	62,8	62,8	68,6	150,7(98,0 ³⁾)	150,7(98,0 ³⁾)	179,5(140,8 ³⁾)	179,5(140,8 ³⁾)	179,5(140,8 ³⁾)
Approved loads, tension	C20/25 appr. N	[kN]	14,6	18,4	24,0	29,9	21,1	38,0	44,9	38,0	48,5	57,9
	C25/30 appr. N	[kN]	16,1	20,3	26,4	32,9	23,3	41,8	49,4	41,8	53,3	63,6
	C30/37 appr. N	[kN]	17,9	22,5	29,2	36,5	25,8	46,4	54,8	46,4	59,2	70,6
	C40/50 appr. N	[kN]	20,6	26,0	33,8	42,2	29,8	53,6	63,3	53,6	68,4	81,6
	C50/60 appr. N	[kN]	22,7	28,6	37,1	46,4	32,8	58,9	69,6	58,9	75,2	89,7
non-cracked concrete												
Approved loads, tension	C20/25 appr. N	[kN]	20,5	25,8	33,5	35,7	29,6	53,2	62,9	53,2	67,9	81,0
	C25/30 appr. N	[kN]	22,5	28,4	36,9	39,3	32,6	58,5	69,1	58,5	74,7	89,1
	C30/37 appr. N	[kN]	25,0	31,5	40,9	43,6	36,1	64,9	76,7	64,9	82,8	98,8
	C40/50 appr. N	[kN]	28,9	36,4	47,3	50,4	40,8	75,0	88,6	75,0	95,7	105,7
	C50/60 appr. N	[kN]	31,8	40,0	52,0	52,9	40,8	82,5	89,5	82,5	105,2	105,7
cracked and non-cracked concrete												
Approved loads, shear	≥ C20/25 appr. V	[kN]	29,3	36,0	36,0	36,0	35,7	76,0	85,1	76,0	97,0	101,7
Approved loads, shear Type LG	≥ C20/25 appr. V	[kN]	29,3	36,0	36,0	36,0	35,7	56,0	56,0	76,0	80,6	80,6
Approved bending moments	appr. M	[Nm]	152,0	152,0	152,0	152,0	200,0	296,6	296,6	512,0	512,0	512,0

Spacing and edge distance

Effective anchorage depth	h_{ef}	[mm]	90	105	125	145	115	170	190	170	200	225
Characteristic spacing	$s_{cr,N}$	[mm]	270	315	375	435	345	510	570	510	600	675
Characteristic edge distance	$c_{cr,N}$	[mm]	135	157,5	187,5	217,5	172,5	255	285	255	300	337,5
cracked concrete												
Minimum thickness of concrete slab	≥ h_{min}	[mm]	130	150	170	190	160	230	250	230	270	300
Minimum spacing	s_{min}	[mm]	50	50	60	60	80	80	80	80	80	80
Minimum edge distance	c_{min}	[mm]	50	50	60	60	80	80	80	80	80	80
non-cracked concrete												
Minimum thickness of concrete slab	≥ h_{min}	[mm]	130	150	170	190	160	230	250	230	270	300
Minimum spacing	s_{min}	[mm]	50	60	60	60	80	80	80	80	105	105
Minimum edge distance	c_{min}	[mm]	50	60	60	60	80	80	80	80	105	105

Installation parameters

Drill hole diameter	d_o	[mm]	18	18	18	18	22	24	24	26	26	26
Diameter of clearance hole in the fixture Pre-installation	d_r	[mm]	18	18	18	18	22	24 (22 ³⁾)	24 (22 ³⁾)	26	26	26
Diameter of clearance hole in the fixture Through fastening ¹⁾	d_r	[mm]	20	20	20	20	24	26	26	28	28	28
Depth of drill hole	h_o	[mm]	98	113	133	153	120	180	200	185	215	240
Installation torque	≤ T_{inst}	[Nm]	50	50	50	50	80	80	80	100	120	120
Width across nut	SW	[mm]	24	24	24	24	30	30	30	36	36	36
Amount of mortar per drill hole ²⁾		[ml]	11,1	12,6	14,5	15,8	20,8	30,1	32,2	33,3	36,6	41,3
Add. amount of mortar per drill hole for Through fastening per 10mm of fixture thickness		[ml/10mm]	1,6	1,6	1,6	1,6	2,1	2,9	2,9	2,6	2,6	2,6
Drill holes per cartridge ²⁾ VMZ 150	[Quan.]		9	8	7	6	5	3	3	3	3	2
Drill holes per cartridge ²⁾ VMZ 345 / VMZ 410	[Quan.]		27/33	23/29	20/25	19/23	14/17	10/12	9/11	9/11	8/10	7/8

¹⁾ The annular gap of the clearance hole must be completely filled with mortar after fixing.

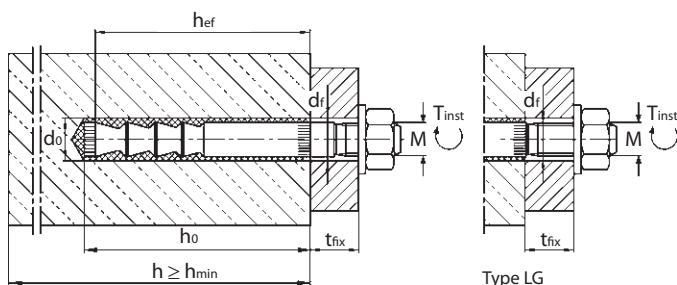
²⁾ Values shown are for pre-installation. For through fastening additional mortar is required to completely fill the clearance hole in the fixture.

³⁾ values in brackets are for Type LG

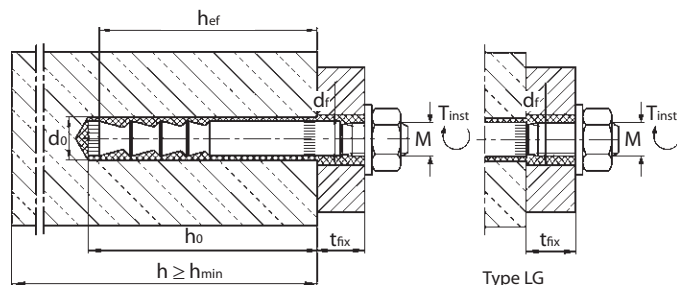
⁴⁾ max. long term temperature +50 °C / max. short term temperature +80 °C

For anchor designing an easy to operate CD-ROM is available on request or can be downloaded at www.mkt.de.

Pre-installation



Through fastening





Extract from Permissible Service Conditions of ETA-04/0092 (M 8 - M 12)

Approved loads for single anchor without influence of spacing and edge distance for temperature range -40°C to +80°C⁵⁾ (Approved loads for temperature range -40°C to +120°C see ETA-04/0092). Total safety factor as per ETAG 001 included (γ_M and γ_P).

Loads and performance data **Injection System VMZ Stainless steel A4 / HCR M8-M12**



			40 M8	50 M8	60 M10	75 M10	75 M12	70 M12	80 M12	95 M12	100 M12	110 M12	125 M12
cracked concrete													
Mean ultimate loads, tension	C25/30	N _{um}	[kN]	12,3	19,5	28,0	29,5	29,5	41,0	48,2	67,2	67,2	67,2
Mean ultimate loads, shear	C25/30	V _{um}	[kN]	17,6	17,6	27,8	27,8	40,5	40,5	40,5	40,5	40,5	40,5
Approved loads, tension	C20/25	appr. N	[kN]	4,3	6,1	8,0	11,1	11,1	10,0	12,3	15,9	17,1	19,8
	C25/30	appr. N	[kN]	4,8	6,7	8,8	11,9	12,2	11,0	13,5	17,5	18,9	21,8
	C30/37	appr. N	[kN]	5,3	7,4	9,7	11,9	13,6	12,2	15,0	19,4	20,9	24,1
	C40/50	appr. N	[kN]	6,1	8,5	11,2	11,9	15,7	14,2	17,3	22,4	24,2	27,1
	C50/60	appr. N	[kN]	6,7	8,6	11,9	11,9	16,7	15,6	19,0	24,6	26,6	27,1
non-cracked concrete													
Approved loads, tension	C20/25	appr. N	[kN]	4,3	8,5	11,2	11,9	15,6	14,1	17,2	19,0	24,0	23,8
	C25/30	appr. N	[kN]	4,7	8,6	11,9	11,9	16,7	15,5	18,9	21,0	26,4	26,2
	C30/37	appr. N	[kN]	5,2	8,6	11,9	11,9	16,7	17,1	21,0	23,2	27,1	27,1
	C40/50	appr. N	[kN]	6,0	8,6	11,9	11,9	16,7	19,8	24,2	25,7	27,1	27,1
	C50/60	appr. N	[kN]	6,6	8,6	11,9	11,9	16,7	21,8	25,7	27,1	27,1	27,1
cracked and non-cracked concrete													
Approved loads, shear	≥ C20/25	appr. V	[kN]	8,6	8,6	13,1	13,1	19,4	19,4	19,4	19,4	19,4	19,4
Approved loads, shear Type LG	≥ C20/25	appr. V	[kN]	8,6	8,6	13,1	13,1	19,4	19,4	19,4	19,4	19,4	19,4
Approved bending moments		appr. M	[Nm]	17,1	17,1	34,3	34,	60,0	60,0	60,0	60,0	60,0	60,0

Spacing and edge distance

Effective anchorage depth	h_{ef}	[mm]	40	50	60	75	75	70	80	95	100	110	125
Characteristic spacing	$s_{cr,N}$	[mm]	120	150	180	225	225	210	240	285	300	330	375
Characteristic edge distance	$c_{cr,N}$	[mm]	60	75	90	112,5	112,5	105	120	142,5	150	165	187,5
cracked concrete													
Minimum thickness of concrete slab	≥ h_{min}	[mm]	80	80	100	110	110	110	110	130	130	140	160
Minimum spacing	s_{min}	[mm]	40	40	40	40	50	55	40	40	50	50	50
Minimum edge distance	c_{min}	[mm]	40	40	40	40	50	55	50	50	50	50	50
non-cracked concrete													
Minimum thickness of concrete slab	≥ h_{min}	[mm]	80	80	100	110	110	110	110	130	130	140	160
Minimum spacing	s_{min}	[mm]	40	40	50	50	50	55	55	55	80 ¹⁾	80 ¹⁾	80 ¹⁾
Minimum edge distance	c_{min}	[mm]	40	40	50	50	50	55	55	55	55 ¹⁾	55 ¹⁾	55 ¹⁾

Installation parameters

Drill hole diameter	d_o	[mm]	10	10	12	12	12	14	14	14	14	14	14
Diameter of clearance hole in the fixture Pre-installation	d_f	[mm]	9	9	12	12	14	14	14	14	14	14	14
Diameter of clearance hole in the fixture Through fastening ²⁾	d_f	[mm]	- ⁴⁾	- ⁴⁾	14	14	14	16	16	16	16	16	16
Depth of drill hole	h_o	[mm]	42	55	65	80	80	75	85	100	105	115	130
Installation torque	≤ T_{inst}	[Nm]	10	10	15	15	25	25	25	25	30	30	30
Width across nut	SW	[mm]	13	13	17	17	19	19	19	19	19	19	19
Amount of mortar per drill hole ³⁾		[ml]	3,4	4,1	6,1	7,0	7,0	6,8	8,6	9,0	9,2	9,4	9,6
Add. amount of mortar per drill hole for Through fastening per 10mm of fixture thickness		[ml/10mm]	-	-	1,0	1,0	0,7	1,2	1,2	1,2	1,2	1,2	1,2
Drill holes per cartridge ³⁾ VMZ 150		[Quan.]	31	26	18	15	15	16	12	12	11	11	11
Drill holes per cartridge ³⁾ VMZ 345/VMZ 410		[Quan.]	88/108	73/90	49/60	43/52	43/52	44/54	34/43	33/41	32/40	32/39	31/38

¹⁾ For edge distance $c \geq 80$ mm, minimal spacing distance $s_{min} = 55$ mm

²⁾ The annular gap of the clearance hole must be completely filled with mortar after fixing.

³⁾ Values shown are for pre-installation. For through fastening additional mortar is required to completely fill the clearance hole in the fixture.

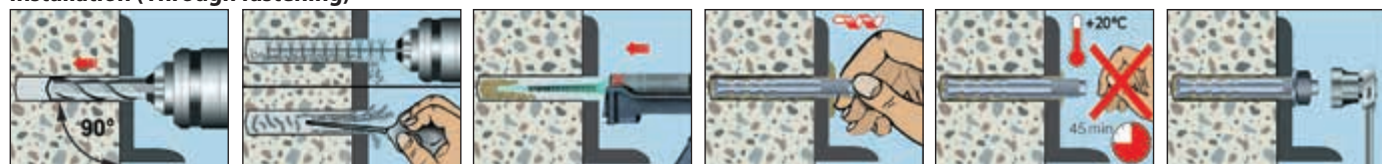
⁴⁾ Not for use in through fastening applications.

⁵⁾ max. long term temperature +50 °C / max. short term temperature +80 °C

Installation (Pre-installation)



Installation (Through fastening)





Extract from Permissible Service Conditions of ETA-04/0092 (M 16 - M 24)

Approved loads for single anchor without influence of spacing and edge distance for temperature range -40°C to +80°C⁴⁾ (Approved loads for temperature range -40°C to +120°C see ETA-04/0092). Total safety factor as per ETAG 001 included (γ_M and γ_P).

Loads and performance data Injection System VMZ Stainless steel A4 / HCR M16-M24

			90	105	125	145	115	170	190	170	200	225
			M16	M16	M16	M16	M20	M20 LG	M20 LG	M24 LG	M 24 LG	M24 LG
cracked concrete												
Mean ultimate loads, tension	C25/30	N_{um} [kN]	49,0	74,8	108,7	108,7	103,3	149,6	149,6	146,2	200,9	200,9
Mean ultimate loads, shear	C25/30	V_{um} [kN]	75,4	75,4	75,4	75,4	102,9	158,2(102,9 ³⁾)	158,2(102,9 ³⁾)	188,4(147,8 ³⁾)	188,4(147,8 ³⁾)	188,4(147,8 ³⁾)
Approved loads, tension	C20/25appr. N	[kN]	14,6	18,4	24,0	29,9	21,1	38,0	44,9	38,0	48,5	57,9
	C25/30appr. N	[kN]	16,1	20,3	26,4	32,9	23,3	41,8	49,4	41,8	53,3	63,6
	C30/37appr. N	[kN]	17,9	22,5	29,2	36,5	25,8	46,4	54,8	46,4	59,2	70,6
	C40/50appr. N	[kN]	20,6	26,0	33,8	42,2	29,8	53,6	63,3	53,6	68,4	81,6
	C50/60appr. N	[kN]	22,7	28,6	37,1	46,4	32,8	58,9	69,6	58,9	75,2	89,7
non-cracked concrete												
Approved loads, tension	C20/25appr. N	[kN]	20,5	25,8	33,5	35,7	29,6	53,2	62,9	53,2	67,9	81,0
	C25/30appr. N	[kN]	22,5	28,4	36,9	39,3	32,6	58,5	69,1	58,5	74,7	89,1
	C30/37appr. N	[kN]	25,0	31,5	40,9	43,6	36,1	64,9	76,7	64,9	82,8	92,4
	C40/50appr. N	[kN]	28,9	36,4	47,3	50,4	41,7	75,0	88,6	75,0	92,4	92,4
	C50/60appr. N	[kN]	31,8	40,0	52,0	52,9	45,9	78,6	93,6	78,6	92,4	92,4
cracked and non-cracked concrete												
Approved loads, shear	\geq C20/25appr. V	[kN]	29,3	36,0	36,0	36,0	42,3	74,9	74,9	76,0	89,1	89,1
Approved loads, shear Type LG	\geq C20/25appr. V	[kN]	29,3	36,0	36,0	36,0	42,3	49,1	49,1	70,3	70,3	70,3
Approved bending moments	appr. M	[Nm]	152,0	152,0	152,0	152,0	231,6	259,4	259,4	448,0	448,0	448,0

Spacing and edge distance

Effective anchorage depth	h_{ef}	[mm]	90	105	125	145	115	170	190	170	200	225
Characteristic spacing	$s_{cr,N}$	[mm]	270	315	375	435	345	510	570	510	600	675
Characteristic edge distance	$c_{cr,N}$	[mm]	135	157,5	187,5	217,5	172,5	255	285	255	300	337,5
cracked concrete												
Minimum thickness of concrete slab	$\geq h_{min}$	[mm]	130	150	170	190	160	230	250	230	270	300
Minimum spacing	s_{min}	[mm]	50	50	60	60	80	80	80	80	80	80
Minimum edge distance	c_{min}	[mm]	50	50	60	60	80	80	80	80	80	80
non-cracked concrete												
Minimum thickness of concrete slab	$\geq h_{min}$	[mm]	130	150	170	190	160	230	250	230	270	300
Minimum spacing	s_{min}	[mm]	50	60	60	60	80	80	80	80	105	105
Minimum edge distance	c_{min}	[mm]	50	60	60	60	80	80	80	80	105	105

Installation parameters

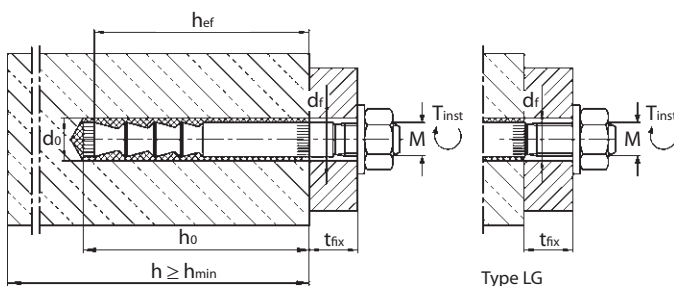
Drill hole diameter	d_o	[mm]	18	18	18	18	22	24	24	26	26	26
Diameter of clearance hole in the fixture Pre-installation	d_r	[mm]	18	18	18	18	22	24 (22 ³⁾)	24 (22 ³⁾)	26	26	26
Diameter of clearance hole in the fixture Through fastening ¹⁾	d_r	[mm]	20	20	20	20	24	26	26	28	28	28
Depth of drill hole	h_o	[mm]	98	113	133	153	120	180	200	185	215	240
Installation torque	$\leq T_{inst}$	[Nm]	50	50	50	50	80	80	80	100	120	120
Width across nut	SW	[mm]	24	24	24	24	30	30	30	36	36	36
Amount of mortar per drill hole ²⁾		[ml]	11,1	12,6	14,5	15,8	20,8	30,1	32,2	33,3	36,6	41,3
Add. amount of mortar per drill hole for Through fastening per 10mm of fixture thickness		[ml/10mm]	1,6	1,6	1,6	1,6	2,1	2,9	2,9	2,6	2,6	2,6
Drill holes per cartridge ²⁾ VMZ 150	[Quan.]		9	8	7	6	5	3	3	3	3	2
Drill holes per cartridge ²⁾ VMZ 345/ VMZ 410	[Quan.]		27/33	23/29	20/25	19/23	14/17	10/12	9/11	9/11	8/10	7/8

¹⁾ The annular gap of the clearance hole must be completely filled with mortar after fixing.
²⁾ Values shown are for pre-installation. For through fastening additional mortar is required to completely fill the clearance hole in the fixture.

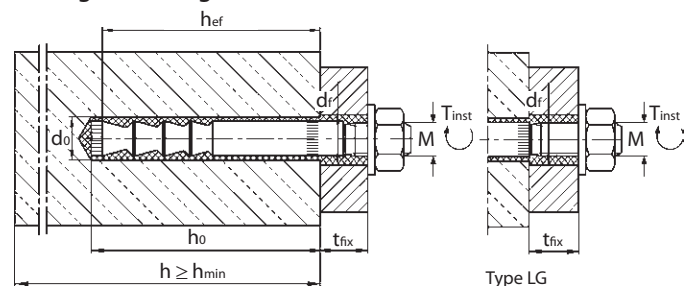
³⁾ values in brackets are for Type LG
⁴⁾ max. long term temperature +50 °C / max. short term temperature +80 °C

For anchor designing an easy to operate CD-ROM is available on request or can be downloaded at www.mkt.de.

Pre-installation



Through fastening



Injection System VMZ-IG



Threaded Stud VMZ-IG
with internal thread



Cartridge VMZ 150
for silicone guns
Content: 150ml



Cartridge VMZ 345
Side-by-side Cartridge
Content: 345ml



Cartridge VMZ 410
Coaxial Cartridge
Content: 410ml



- Range of loading:** 4,3 kN - 53,2 kN
- Range of concrete quality:** C20/25 - C50/60
- Material:** Steel, zinc plated, Stainless steel A4, Stainless steel HCR

Description

The Injection System VMZ-IG consists of an internally threaded sleeve with conical expansion elements and a 2 component injection adhesive. This combination provides extremely high load bearing capacity even at minimum edge distance and spacing. The VMZ system combines the benefits of bonded anchors and expansion anchors in a European technical approved fastening system for both cracked and non-cracked concrete.

Advantages:

- small thickness of concrete slab
- no load reduction for wet or water-filled (M10 and larger) drill holes
- approved from -5 °C to +40°C temperature of base material while installation
- sealed drill hole
- no projection parts after de-installation of fixture
- opened cartridges can be re-used with a new mixer nozzle

Threaded Stud VMZ-IG

Steel, zinc plated



- May be used in structures subject to dry internal conditions
- With internal thread, to be used with standard screws or threaded studs (steel strength 8.8)

Description	Ref. No.	Drill hole Øxdepth mm	Effective anchorage depth mm	Anchoring length mm	Thread	Pkg. cont. pcs.	Weight per pkg. kg
VMZ-IG 40 M6	32802101	10x42	40	41	M6x12	10	0,15
VMZ-IG 50 M6	32804101	10x55	50	52	M6x15	10	0,18
VMZ-IG 60 M8	32812101	12x65	60	63	M8x16	10	0,28
VMZ-IG 75 M8	32814101	12x80	75	78	M8x19	10	0,47
VMZ-IG 70 M10	32822101	14x80	70	74	M10x20	10	0,57
VMZ-IG 80 M10	32824101	14x85	80	84	M10x23	10	0,63
VMZ-IG 90 M12	32832101	18x98	90	94	M12x24	10	1,26
VMZ-IG 105 M12	32834101	18x113	105	109	M12x27	10	1,45
VMZ-IG 125 M12	32836101	18x133	125	130	M12x30	10	1,69
VMZ-IG 115 M16	32852101	22x120	115	120	M16x32	5	1,12
VMZ-IG 170 M16	32854101	24x180	170	180	M16x32	5	2,22
VMZ-IG 170 M20	32862101	26x185	170	182	M20x40	5	2,44



Applications:

Heavy duty fastenings in cracked and non-cracked concrete with standards screws or threaded studs: Steel structures, brackets, railings, posts, columns, ladders, gates

Injection Cartridge VMZ



- Two component cartridge, styrene-free
- Various cartridge systems
- Approved for cracked and non-cracked concrete

Description	Ref. No.	Content ml	Content of master box pcs.	Weight per master box kg	Weight per piece kg
Cartridge VMZ 150	28999301	150	12	4,32	0,36
Cartridge VMZ 345	28255310	345	12	8,28	0,69
Cartridge VMZ 410	28254701	410	12	9,84	0,82
Static mixer VM-X	28305111	-	12	0,12	0,01
Mixer extension VM-XE (200mm)	28306011	-	12	-	0,01
Installation wedge VMZ-MK	33300103	-	10	-	0,01

One static mixer VM-X as well as one screw-on cap comes with each cartridge.

Dispenser and Accessories for drill hole cleaning see page 49 or 59.

Threaded Stud VMZ-IG A4

Edelstahl A4 / 316



- May be used in structures subject to dry internal conditions or external atmospheric exposure
- With internal thread, to be used with standard screws or threaded studs (steel strength 70)

Description	Ref. No.	Drill hole Øxdepth mm	Effective anchorage depth mm	Anchoring length mm	Thread	Pkg. cont. pcs.	Weight per pkg. kg
VMZ-IG 40 M6 A4	32802501	10x42	40	41	M6x12	10	0,15
VMZ-IG 50 M6 A4	32804501	10x55	50	52	M6x15	10	0,18
VMZ-IG 60 M8 A4	32812501	12x65	60	63	M8x16	10	0,28
VMZ-IG 75 M8 A4	32814501	12x80	75	78	M8x19	10	0,47
VMZ-IG 70 M10 A4	32822501	14x80	70	74	M10x20	10	0,57
VMZ-IG 80 M10 A4	32824501	14x85	80	84	M10x23	10	0,63
VMZ-IG 90 M12 A4	32832501	18x98	90	94	M12x24	10	1,26
VMZ-IG 105 M12 A4	32834501	18x113	105	109	M12x27	10	1,45
VMZ-IG 125 M12 A4	32836501	18x133	125	130	M12x30	10	1,69
VMZ-IG 115 M16 A4	32852501	22x120	115	120	M16x32	5	1,12
VMZ-IG 170 M16 A4	32854501	24x180	170	180	M16x32	5	2,22
VMZ-IG 170 M20 A4	32862501	26x185	170	182	M20x40	5	2,44



Extract from Permissible Service Conditions of ETA-04/0092

Approved loads for single anchor without influence of spacing and edge distance for temperature range -40°C to +80°C¹⁾ (Approved loads for temperature range -40°C to +120°C see ETA-04/0092). Total safety factor as per ETAG 001 included (γ_M and γ_P).

Loads and performance data Injection System VMZ-IG, steel zinc plated and stainless steel A4 / HCR



			40	50	60	75	70	80	90	105	125	115	170	170
			M6	M6	M8	M8	M10	M10	M12	M12	M12	M16	M16	M20
VMZ-IG, steel zinc plated			cracked concrete											
Approved loads, tension	C20/25	appr. N [kN]	4,3	6,1	8,0	11,1	10,0	12,3	14,6	18,4	24,0	21,1	38,0	38,0
			non-cracked concrete											
Approved loads, tension	C20/25	appr. N [kN]	4,3	7,6	9,0	13,8	14,1	16,7	20,5	25,8	31,9	24,8	53,2	51,4
			cracked and non-cracked concrete											
Approved loads, shear	≥ C20/25	appr. V [kN]	4,6	4,6	5,4	8,6	10,3	10,3	19,4	19,4	19,4	14,9	36,0	30,9
Approved bending moments		appr. M [Nm]	6,9	6,9	17,1	17,1	34,3	34,3	60,0	60,0	60,0	121,1	152,0	296,6

VMZ-IG, stainless steel A4 / HCR			cracked concrete											
Approved loads, tension	C20/25	appr. N [kN]	4,3	5,2	8,0	10,0	10,0	12,3	14,6	18,4	22,4	21,1	38,0	38,0
			non-cracked concrete											
Approved loads, tension	C20/25	appr. N [kN]	4,3	5,2	9,0	10,0	14,1	15,7	20,5	22,4	22,4	29,6	41,9	44,8
			cracked and non-cracked concrete											
Approved loads, shear	≥ C20/25	appr. V [kN]	3,1	3,1	5,4	5,7	9,1	9,1	13,7	13,7	13,7	18,3	25,1	26,9
Approved bending moments		appr. M [Nm]	4,9	4,9	12,0	12,0	24,0	24,0	42,3	42,3	42,3	106,9	106,9	208,6

Spacing and edge distance

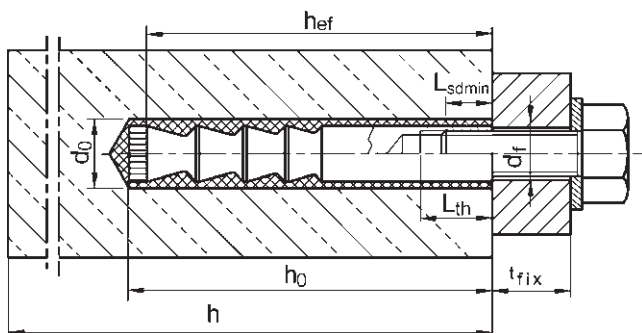
Effective anchorage depth	h_{ef}	[mm]	40	50	60	75	70	80	90	105	125	115	170	170
Characteristic spacing	$s_{cr,N}$	[mm]	120	150	180	225	210	240	270	315	375	345	510	510
Characteristic edge distance	$c_{cr,N}$	[mm]	60	75	90	112,5	105	120	135	157,5	187,5	172,5	255	255
			cracked concrete											
Minimum thickness of concrete slab	≥ h_{min}	[mm]	80	80	100	110	110	110	130	150	170	160	230	230
Minimum spacing	s_{min}	[mm]	40	40	40	40	55	40	50	50	60	80	80	80
Minimum edge distance	c_{min}	[mm]	40	40	40	40	55	50	50	50	60	80	80	80
			non-cracked concrete											
Minimum thickness of concrete slab	≥ h_{min}	[mm]	80	80	100	110	110	110	130	150	170	160	230	230
Minimum spacing	s_{min}	[mm]	40	40	50	50	55	55	50	60	60	80	80	80
Minimum edge distance	c_{min}	[mm]	40	40	50	50	55	55	50	60	60	80	80	80

Installation parameters

Drill hole diameter	d_o	[mm]	10	10	12	12	14	14	18	18	18	22	24	26
Diameter of clearance hole in the fixture	d_f	[mm]	7	7	9	9	12	12	14	14	14	18	18	22
Depth of drill hole	h_o	[mm]	42	55	65	80	80	85	98	113	133	120	180	185
Installation torque	≤ T_{inst}	[Nm]	8	8	10	10	15	15	25	25	25	50	50	80
Minimum screwing depth	L_{sdmin}	[mm]	7	7	9	9	12	12	14	14	14	18	18	22
Maximum screwing depth	L_{th}	[mm]	12	15	16	19	20	23	24	27	30	32	32	40
Amount of mortar per drill hole		[ml]	3,4	4,1	6,1	7,0	6,8	8,6	11,1	12,6	14,5	20,8	30,1	33,3
Drill holes per cartridge VMZ 150		[Quan.]	31	26	18	15	16	12	9	8	7	5	3	3
Drill holes per cartridge VMZ 345		[Quan.]	88	73	49	43	44	34	27	23	20	14	10	9
Drill holes per cartridge VMZ 410		[Quan.]	108	90	60	52	54	43	33	29	25	17	12	11

¹⁾ max. long term temperature +50 °C / max. short term temperature +80 °C

For anchor designing an easy to operate CD-ROM is available on request or can be downloaded at www.mkt.de.



Installation



Curing Time Injection Adhesive VMZ

→ Cartridge temperature when installing min. +5°C

Temperature (°C) of the base material	Gel time	Curing time	
		dry base material	wet base material
-5°C	1:30 h	6:00 h	12:00 h
0°C	45 min	3:00 h	6:00 h
+5°C	20 min	2:00 h	4:00 h
+10°C	12 min	1:20 h	2:40 h
+20°C	6 min	45 min	1:30 h
+30°C	4 min	25 min	50 min
+35°C	2 min	20 min	40 min
+40°C	1,4 min	15 min	30 min

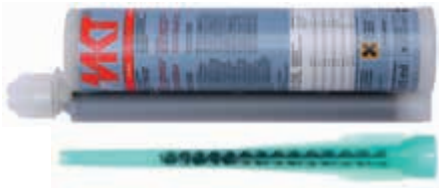
Injection System VMZ **dynamic**



Threaded Stud VMZ-A dynamic



Cartridge VMZ 150
for silicone guns
Content: 150ml



Cartridge VMZ 345
Side-by-side Cartridge
Content: 345ml



Cartridge VMZ 410
Coaxial Cartridge
Content: 410ml



Range of loading: 4,7 kN - 31,9 kN
Range of concrete quality: C20/25 - C50/60
Material: Steel, zinc plated, Stainless steel HCR

Applications

Heavy duty fastenings with alternating loads and unlimited load cycles in cracked and non-cracked concrete:
 Cranes, industrial robots, antenna towers, noise barriers, elevators

Description

The Injection System VMZ dynamic consists of an anchor rod with conical expansion elements and a 2 component injection adhesive. This combination provides extremely high load bearing capacity even at minimum edge distance and spacing. The VMZ system combines the benefits of bonded anchors and expansion anchors in an approved fastening system for both cracked and non-cracked concrete.

Advantages:

- small thickness of concrete slab
- no load reduction for wet or water-filled drill holes
- approved from -5 °C to +40°C temperature of base material while installation
- through-setting installation without subsequent filling the annular gap in the fixture
- sealed drill hole
- special nut and washer to account for angular misalignment
- opened cartridges can be re-used with a new mixer nozzle
- pre-assembled anchor, additional locknut included
- very high loads in axial and oblique tension
- higher loads, if number of load cycles is limited
- static and alternating loads may be taken into account in the design of the anchorage

Injection Cartridge VMZ



- Two component cartridge, styrene-free
- Various cartridge systems
- Approved for cracked and non-cracked concrete

Description	Ref. No.	Content ml	Content of master box pcs.	Weight per master box kg	Weight per piece kg
Cartridge VMZ 150	28999301	150	12	4,32	0,36
Cartridge VMZ 345	28255310	345	12	8,28	0,69
Cartridge VMZ 410	28254701	410	12	9,84	0,82
Static mixer VM-X	28305111	-	12	0,12	0,01
Mixer extension VM-XE (200mm)	28306011	-	12	-	0,01
Installation wedge VMZ-MK	33300103	-	10	-	0,01

One static mixer VM-X as well as one screw-on cap comes with each cartridge.

Dispenser and Accessories for drill hole cleaning see page 59.

Threaded Stud VMZ-A dynamic

Steel, zinc plated



→ May be used in structures subject to dry internal conditions

→ Approved for cracked and non-cracked concrete as well as for fatigue loads

Description	Ref. No.	Drill hole Ø do mm	Drill hole depth		Fixture thickness		Drill hole depth through fixture hd mm	Anchor- length mm	Pkg. cont. pcs.	Weight per pkg. kg	Amount of mortar per anchor ml	Anchors per cartridge		
			ho mm min	max	tfix mm min	max						150 ml	345 ml	410 ml
VMZ-A 100 M12-25/160 dyn	36375101	14	105	118	12	25	130	160	10	2,22	12,2	9	25	30
VMZ-A 100 M12-50/181 dyn	36385101	14	105	143	12	50	155	181	10	2,46	15,2	7	20	24
VMZ-A 125 M16-30/195 dyn	36520101	18	133	147	16	30	163	195	10	4,20	19,3	5	15	19
VMZ-A 125 M16-50/215 dyn	36525101	18	133	167	16	50	183	215	10	4,54	22,5	4	13	16
VMZ-A 170 M20-50/280 dyn	36610101	24	180	210	20	50	230	280	5	4,64	44,6	2	6	8

Threaded Stud VMZ-A dynamic HCR

Stainless steel HCR



→ May be used in structures subject to external atmospheric exposure and in particularly corrosive environments

→ Approved for cracked and non-cracked concrete as well as for fatigue loads

→ High Corrosion Resistant Steel grade 1.4529

Description	Ref. No.	Drill hole Ø do mm	Drill hole depth		Fixture thickness		Drill hole depth through fixture hd mm	Anchor- length mm	Pkg. cont. pcs.	Weight per pkg. kg	Amount of mortar per anchor ml	Anchors per cartridge		
			ho mm min	max	tfix mm min	max						150 ml	345 ml	410 ml
VMZ-A 125 M16-25/185 dyn HCR	36520651	18	133	147	16	25	163	185	10	3,02	18,5	6	16	20
VMZ-A 125 M16-50/210 dyn HCR	36525651	18	133	167	16	50	183	210	10	3,44	22,5	4	13	16

Other lengths or threads on demand.



Curing Time Injection Adhesive VMZ

→ Cartridge temperature when process min. +5°C

Temperature (°C) of the base material	Gel time	Curing time	
		dry concrete	wet concrete
-5°C	1:30 h	6:00 h	12:00 h
0°C	45 min	3:00 h	6:00 h
+5°C	20 min	2:00 h	4:00 h
+10°C	12 min	1:20 h	2:40 h
+20°C	6 min	45 min	1:30 h
+30°C	4 min	25 min	50 min
+35°C	2 min	20 min	40 min
+40°C	1,4 min	15 min	30 min



Extract from Permissible Service Conditions of approval Z-21.3-1906

Approved loads from not static loading for single anchor without influence of spacing and edge distance for temperature range -40°C to +80°C⁴⁾ (Approved loads for temperature range -40°C to +120°C see ETA-04/0092). Total safety factor as per ETAG 001 included (γ_M and γ_P).

Loads and performance data

Injection System VMZ dynamic

			100 M 12 steel zinc plated	125 M 16 steel zinc plated	170 M 20 steel zinc plated	125 M 16 stainless steel HCR
Effective anchorage depth	h_{ef}	[mm]	100	125	170	125
Single fixing			cracked and non-cracked concrete			
Approved loads, tension	C20/25 ΔN_{appr}	[kN]	14,8	22,4	31,9	22,4
Approved loads, shear	C20/25 ΔV_{appr}	[kN]	6,1	11,1	15,6	11,1
Approved loads, oblique tension (45°)	C20/25 $\Delta F_{appr,45^\circ}$	[kN]	7,4	13,2	18,1	13,4
Multiple use (per anchor)			cracked and non-cracked concrete			
Approved loads, tension	C20/25 ΔN_{appr}	[kN]	11,4	19,4	24,5	21,1
Approved loads, shear	C20/25 ΔV_{appr}	[kN]	4,7	8,5	12,0	8,5
Approved loads, oblique tension (45°)	C20/25 $\Delta F_{appr,45^\circ}$	[kN]	5,7	10,2	13,9	10,3
Spacing and edge distance						
Characteristic spacing	$s_{cr,N}$	[mm]	300	375	510	375
Characteristic edge distance	$c_{cr,N}$	[mm]	150	187,5	255	187,5
Minimum spacing	s_{min}	[mm]	50 (80) ²⁾	60	80	60
Minimum edge distance	c_{min}	[mm]	50 (55) ²⁾	60	80	60
Minimum thickness of concrete slab	h_{min}	[mm]	130	170	230	170
Installation parameters						
Drill hole diameter	d_o	[mm]	14	18	24	18
Depth of drill hole ³⁾	h_o	[mm]	105	133	180	133
Diameter of clearance hole in the fixture	d_f	[mm]	15	19	25	19
Installation torque	T_{inst}	[Nm]	30	50	80	50
Width across nut	SW	[mm]	18	24	30	24
Minimum thickness of fixture	$t_{fix} \geq$	[mm]	12	16	20	16
Diameter conical seats	d_1	[mm]	36	44	50	38
Thickness conical seats	h_1	[mm]	6	7	8	7

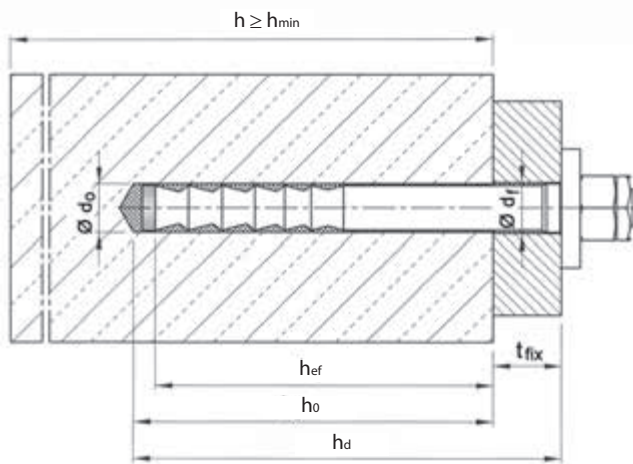
¹⁾ max. long term temperature +50 °C / max. short term temperature +80 °C .

²⁾ values in brackets are for non-cracked concrete.

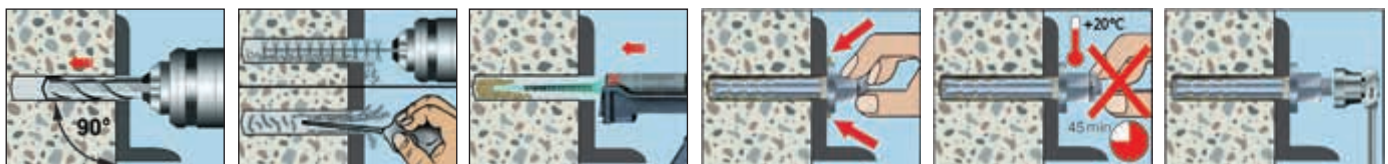
³⁾ If the maximum fixture thickness t_{fix} is not completely used, the depth of drill hole and the setting depth of the anchor have to be increased accordingly.

For anchor designing an easy to operate Software is available on request or can be downloaded at www.mkt.de

Amount of mortar per anchor see page 57.



Installation



Cleaning Brush RB M6



RB M6, with connection thread M6



RBL M6, with internal and external thread M6



RBL M6 SDS, with internal thread M6

- With connection thread M6 – extension for large depths of drill hole and/or for through-setting installation
- For drilling machines with keyed chuck or with SDS adaptor for SDS plus drills

Description	Ref. No.	Suitable for drill hole Ø mm	Total length of brush mm	Suitable for			Pkg. cont. pcs.	Weight per piece kg
				VMZ-A	VMZ-A dyn	VMZ-IG		
RB 10 M6	33510101	10	130	M8	-	M6	1	0,05
RB 12 M6	33512101	12	140	M10, 75 M12	-	M8	1	0,05
RB 14 M6	33514101	14	180	M12	M12	M10	1	0,05
RB 18 M6	33518101	18	200	M16	M16	M12	1	0,05
RB 22 M6	33522101	22	220	115 M20	-	115 M16	1	0,05
RB 24 M6	33524101	24	250	M20	M20	M16	1	0,06
RB 26 M6	33526101	26	290	M24	-	M20	1	0,06
RBL M6	33968101	Brush extension 150mm with connection thread M6					1	0,09
RBL M6 SDS	33350101	SDS Plus adapter with internal thread M6					1	0,06

Blow-out pump VM-AP



- Drill hole cleaning for VMZ-A M8-M16, VMZ-A dyn M12-M16 and VMZ-IG M6-M12

Description	Ref. No.	Max. depth of drill hole or max. depth of drill hole with fixture (through fastening) mm	Pkg. cont. pcs.	Weight per piece kg
VM-AP 360, blow-out pump	33200101	300	1	0,27

Air gun VM-ABP



- Drill hole cleaning with compressed air for VMZ-A M20-M24, VMZ-A dyn M20 and VMZ-IG M16-M20

Description	Ref. No.	Max. depth of drill hole or max. depth of drill hole with fixture (through fastening) mm	Pkg. cont. pcs.	Weight per piece kg
VM-ABP 250	33100101	240	1	1,00
VM-ABP 500	33106101	480	1	1,30

Dispenser VM-P Profi



- Professional dispenser with an ideal center of gravity for more comfortable working
- Automatic pressure release for minimum material overrun

Description	Ref. No.	Suitable for cartridge	Pkg. cont. pcs.	Weight per piece kg
VM-P 345 Profi	28350511	150ml, 280ml, 300ml, 345ml also suitable for silicone cartridges	1	1,00
VM-P 380 Profi	28351001	380ml, 410ml, 420ml	1	1,10

Dispenser VM-P Standard



- For occasional use, metal version
- Piston rod with adjusting screw

Description	Ref. No.	Suitable for cartridge	Pkg. cont. pcs.	Weight per piece kg
VM-P 345 Standard	28350505	150ml, 280ml, 300ml, 345ml also suitable for silicone cartridges	1	1,00
VM-P 380 Standard	28353005	380ml, 410ml, 420ml	1	1,15

Dispenser VM-P Pneumatic

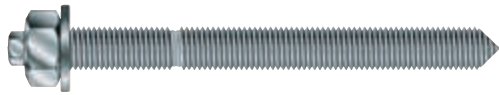


- Professional air tool with an optimum center of gravity and quick cartridge exchange
- Automatic pressure release system reduces material overrun to a minimum
- Single-hand pressure regulation to adjust the piston speed

Description	Ref. No.	Suitable for cartridge	max. working pressure 8bar, 40l/min	Pkg. cont. pcs.	Weight per piece kg
VM-P 345 Pneumatic	28350601	345ml	1	2,41	
VM-P 380 Pneumatic	28352002	380ml, 410ml, 420ml	1	2,00	

Chemical Anchors

Chemical Anchor V



Threaded Stud V-A



Chemical Capsule V-P

Description

The Chemical Anchor V with ETA approval consists of a glass capsule filled with resin, hardener and filler-material, as well as the Threaded Stud V-A. The components in the capsule are mixed to a fast curing resin-mortar when the threaded stud is inserted into the drill-hole. This stress free anchoring system has been tried and tested for decades and allows for mounting of heavy loads even with smaller spacings and edge distances in non-cracked concrete. All Sizes of Threaded Stud V-A are also available in grade 8.8 steel on demand.

Advantages:

- Anchor-rods with external hexagon for fast and easy installation
- every package includes an adapter for the drilling machine
- excellent suitability for high volume fixing
- sealed drill-hole
- extensive product range for all uses
- usable in damp and dry concrete
- also with large washer for crash-barrier mounting
- economic special lengths without external hexagon available

Applications

Anchoring of heavy loads in non-cracked concrete: trusses, foot and headplates, consoles, crash-barriers, noise-protection walls.



Range of loading:

3,0 kN - 80,6 kN

Range of concrete quality:

C12/15 - C50/60

Material:

Steel, zinc plated, Steel, hot dip galvanized, Stainless steel A4, HCR



F30-F120
M8 - M12
M16 - M24



Chemical Capsule V-P



→ Two component glass capsule

→ Approved for non-cracked concrete

Description	Ref. No.	Capsule Ø	Capsule-length	Content of master box	Weight per master box	Package content	Weight per package
		mm	mm	pcs.	kg	pcs.	kg
V-P 8	25100801	9	80	500	7,02	10	0,13
V-P 10	25101001	11	80	500	8,50	10	0,16
V-P 12	25101201	13	95	500	12,30	10	0,25
V-P 14 ¹⁾	25101401	15	95	500	15,82	10	0,27
V-P 16	25101601	17	95	500	19,36	10	0,36
V-P 20	25102001	22	175	-	-	10	1,20
V-P 24	25102401	24	210	-	-	5	0,87
V-P 30 ¹⁾	25103001	33	265	-	-	5	2,10

¹⁾ Not part of approval.

Curing Time Chemical Anchor

→ Capsule temperature when installing min. +5°

Temperature (°C) of the base material	Curing time	
	dry concrete	wet concrete
-5°C	5:00 h	10:00 h
0°C	5:00 h	10:00 h
+5°C	1:00 h	2:00 h
+10°C	1:00 h	2:00 h
+20°C	20 min	40 min
+30°C	10 min	20 min
+35°C	10 min	20 min

Threaded Stud V-A



- May be used in structures subject to dry internal conditions
- Steel, zinc plated 5.8
- Approved for non-cracked concrete

Description	Ref. No.	Drill hole Ø x depth	Fixture thickness t _{fix}	Package content	Weight per package
		mm	mm	pcs.	kg
V-A 8-20/110	21101101	10 x 80	20	10	0,43
V-A 8-60/150	21105101	10 x 80	60	10	0,53
V-A 10-15/115	21202101	12 x 90	15	10	0,73
V-A 10-30/130	21203101	12 x 90	30	10	0,81
V-A 10-65/165	21207101	12 x 90	65	10	0,98
V-A 10-90/190	21210101	12 x 90	90	10	1,11
V-A 10-150/250	21216101	12 x 90	150	10	1,42
V-A 10-200/300	21221101	12 x 90	200	10	1,71
V-A 12-10/135	21304101	14 x 110	10	10	1,19
V-A 12-35/160	21306101	14 x 110	35	10	1,37
V-A 12-85/210	21312101	14 x 110	85	10	1,73
V-A 12-95/220	21313101	14 x 110	95	10	1,82
V-A 12-125/250	21316101	14 x 110	125	10	2,02
V-A 12-175/300	21321101	14 x 110	175	10	2,83
V-A 14-35/170 ¹⁾	21408101	16 x 120	35	10	1,91
V-A 16-20/165	21507101	18 x 125	20	10	2,77
V-A 16-45/190	21510101	18 x 125	45	10	2,96
V-A 16-85/230	21514101	18 x 125	85	10	3,65
V-A 16-105/250	21516101	18 x 125	105	10	3,91
V-A 16-155/300	21521101	18 x 125	155	10	4,58
V-A 20-20/220	21613101	25 x 170	20	10	5,56
V-A 20-60/260	21617101	25 x 170	60	10	6,39
V-A 20-100/300	21621101	25 x 170	100	10	7,23
V-A 24-15/260	21717101	28 x 210	15	5	4,89
V-A 24-55/300	21721101	28 x 210	55	5	5,54
V-A 30-70/380 ^{1) 2)}	21829101	35 x 280	70	5	10,00

Other lengths and grade 8.8 on demand.

¹⁾ Not part of approval.

²⁾ Setting tool V-A 30-70/380 ref. no. 27805160 to be ordered separately.

Threaded Stud V-A A4



- May be used in structures subject to dry internal conditions or external atmospheric exposure
- Stainless Steel A4
- Approved for non-cracked concrete

Description	Ref. No.	Drill hole Ø x depth	Fixture thickness t _{fix}	Package content	Weight per package
		mm	mm	pcs.	kg
V-A 8-20/110 A4	21101501	10 x 80	20	10	0,43
V-A 8-60/150 A4	21105501	10 x 80	60	10	0,53
V-A 10-15/115 A4	21202501	12 x 90	15	10	0,73
V-A 10-30/130 A4	21203501	12 x 90	30	10	0,81
V-A 10-65/165 A4	21207501	12 x 90	65	10	0,98
V-A 10-90/190 A4	21210501	12 x 90	90	10	1,11
V-A 10-150/250 A4	21216501	12 x 90	150	10	1,42
V-A 10-200/300 A4	21221501	12 x 90	200	10	1,71
V-A 12-10/135 A4	21304501	14 x 110	10	10	1,19
V-A 12-35/160 A4	21306501	14 x 110	35	10	1,37
V-A 12-55/180 A4	21309501	14 x 110	55	10	1,51
V-A 12-85/210 A4	21312501	14 x 110	85	10	1,73
V-A 12-95/220 A4	21313501	14 x 110	95	10	1,82
V-A 12-125/250 A4	21316501	14 x 110	125	10	2,02
V-A 12-175/300 A4	21321501	14 x 110	175	10	2,83
V-A 14-35/170 A4 ¹⁾	21408501	16 x 120	35	10	1,91
V-A 16-5/150 A4	21505501	18 x 125	5	10	2,38
V-A 16-20/165 A4	21507501	18 x 125	20	10	2,77
V-A 16-45/190 A4	21510501	18 x 125	45	10	2,96
V-A 16-65/210 A4	21512501	18 x 125	65	10	3,20
V-A 16-85/230 A4	21514501	18 x 125	85	10	3,65
V-A 16-105/250 A4	21516501	18 x 125	105	10	3,91
V-A 16-155/300 A4	21521501	18 x 125	155	10	4,58
V-A 20-20/220 A4	21613501	25 x 170	20	10	5,56
V-A 20-60/260 A4	21617501	25 x 170	60	10	6,39
V-A 20-100/300 A4	21621501	25 x 170	100	10	7,23
V-A 24-15/220 A4 ^{1) 2)}	21713580	28 x 170	15	5	4,28
V-A 24-15/260 A4	21717501	28 x 210	15	5	4,89
V-A 24-55/300 A4	21721501	28 x 210	55	5	5,54
V-A 30-70/380 A4 ^{1) 3)}	21829501	35 x 280	70	5	10,00

Other lengths on demand.

¹⁾ Not part of approval.

²⁾ Setting with capsule V-P 20.

³⁾ Setting tool V-A 30-70/380 ref. no. 27805160 to be ordered separately.

Threaded Stud V-A



- Better corrosion resistant
- Steel, hot dip galvanized 5.8 (≥ 40µm, EN ISO 1461)
- Approved for non-cracked concrete

Description	Ref. No.	Drill hole Ø x depth	Fixture thickness t _{fix}	Package content	Weight per package
		mm	mm	pcs.	kg
V-A 8-20/110	21101201	10 x 80	20	10	0,43
V-A 10-30/130	21203201	12 x 90	30	10	0,81
V-A 10-90/190	21210201	12 x 90	90	10	1,11
V-A 12-35/160	21306201	14 x 110	35	10	1,37
V-A 12-95/220	21313201	14 x 110	95	10	1,82
V-A 16-20/165	21507201	18 x 125	20	10	2,77
V-A 16-45/190	21510201	18 x 125	45	10	2,96
V-A 16-65/210	21512201	18 x 125	65	10	3,20
V-A 20-20/220	21613201	25 x 170	20	10	5,56
V-A 20-60/260	21617201	25 x 170	60	10	6,39
V-A 24-15/260	21717201	28 x 210	15	5	4,89
V-A 24-55/300	21721201	28 x 210	55	5	5,54

Other lengths and grade 8.8 on demand.

Threaded Stud V-A HCR

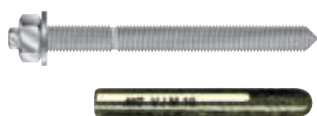


- For use in particularly corrosive environments
- High corrosion resistant steel 1.4529 (HCR)
- Approved for non-cracked concrete

Description	Ref. No.	Drill hole Ø x depth	Fixture thickness t _{fix}	Package content	Weight per package
		mm	mm	pcs.	kg
V-A 8-20/110 HCR	21101651	10 x 80	20	10	0,43
V-A 10-30/130 HCR	21203651	12 x 90	30	10	0,81
V-A 12-35/160 HCR	21306651	14 x 110	35	10	1,37
V-A 16-45/190 HCR	21510651	18 x 125	45	10	2,96

Other lengths on demand.

Chemical Anchor V-L



→ Steel, hot dip galvanized; Stainless steel

→ Set, specially designed for crash barriers

Description	Ref. No.	Drill hole Ø x depth mm	Stud Ø x length mm	Fixture thickness t _{fix} mm	Package content pcs.	Weight per set kg
V-L 16-20/165 hot dip galvanized washer DIN125 (Ø=30 mm)	23507201	18x125	M16x165	20	10	3,13
V-L 16-20/165 hot dip galvanized washer DIN9021 (Ø=50 mm)	23507791	18x125	M16x165	20	10	3,32
V-L 16-20/165 stainless steel A4/316 washer DIN125 (Ø=30 mm)	23507501	18x125	M16x165	20	10	3,13

Cleaning Brush RB M6



→ With connection thread M6 – extension for large depths of drill hole and/or for through-setting installation

→ For drilling machines with keyed chuck or with SDS adaptor for SDS plus drills

Description	Ref. No.	Suitable for drill hole Ø mm	Suitable for	Package content pcs.	Weight per piece kg
RB 10 M6	33510101	10	V M8	1	0,05
RB 12 M6	33512101	12	V M10	1	0,05
RB 14 M6	33514101	14	V M12	1	0,05
RB 16 M6	33516101	16	V M14	1	0,05
RB 18 M6	33518101	18	V M16	1	0,05
RB 26 M6	33526101	25, 26	V M20	1	0,06
RB 28 M6	33528101	28	V M24	1	0,06
RB 35 M6	33535101	35	V M30	1	0,08
RBL M6	33968101	Brush extension 150 mm with connection thread M6		1	0,09
RBL M6 SDS	33350101	SDS Plus adapter for cleaning brush (M6)		1	0,06

Blow-out pump VM-AP



→ Drill hole cleaning

Description	Ref. No.	Suitable for drill hole Ø mm	Length mm	max. depth drill hole mm	Package content pcs.	Weight per piece kg
VM-AP 270	29990002	12-35	270	200	1	0,22
VM-AP 360	33200101	10-35	360	300	1	0,27

Setting Tool V-M



→ Only needed for special length and studs without external Hexagon

Description	Ref. No.	Suitable for threaded stud	Package content pes.	Weight per piece kg
V-M 8	27105160	M8	1	0,02
V-M 10	27205160	M10	1	0,03
V-M 12	27305160	M12	1	0,05
V-M 14	27405160	M14	1	0,05
V-M 16	27505160	M16	1	0,06
V-M 20	27605160	M20	1	0,20
V-M 24	27705160	M24	1	0,33
V-M 30	27805160	M30	1	0,63



Extract from Permissible Service Conditions of ETA-05/0231

Approved loads for single anchor without influence of spacing and edge distance for temperature range -40 °C to +80 °C². Total safety factor as per ETAG 001 included (γ_M and γ_F).

Loads and performance data	Chemical Anchor V, steel, zinc plated / hot dip galvanized			M 8	M 10	M 12	M 14 ¹⁾	M 16	M 20	M 24	M 30 ¹⁾
				non-cracked concrete							
Mean ultimate loads, tension	C25/30	N _{um}	[kN]	27,0	38,6	58,2	73,5	104,3	169,8	250,2	442,9
Mean ultimate loads, shear	C25/30	V _{um}	[kN]	15,4	24,4	35,4	48,4	66,0	103,0	148,3	235,7
Approved loads, tension		C12/15 ¹⁾ zul. N	[kN]	3,0	5,0	7,0	8,0	10,0	19,0	26,0	42,0
		≥ C20/25 zul. N	[kN]	7,9	11,9	15,9	12,0	19,8	29,8	35,7	60,0
Approved loads, shear		C12/15 ¹⁾ zul. V	[kN]	3,0	5,0	7,0	8,0	10,0	19,0	26,0	42,0
		≥ C20/25 zul. V	[kN]	5,1	8,0	12,0	12,0	22,3	34,9	50,3	60,0
Approved loads, shear (steel, grade 8.8)		≥ C20/25 zul. V	[kN]	8,6	13,1	18,9	-	36,0	56,0	80,6	-
Approved bending moments (steel, grade 5.8)		zul. M	[Nm]	10,9	21,1	37,1	59,4	94,9	185,7	320,6	642,0
Approved bending moments (steel, grade 8.8)		zul. M	[Nm]	17,1	34,3	60,0	-	152,0	296,6	513,1	-

Loads and performance data	Chemical Anchor V, stainless steel A4 / HCR			M 8	M 10	M 12	M 14 ¹⁾	M 16	M 20	M 24	M 30 ¹⁾
				non-cracked concrete							
Mean ultimate loads, tension	C25/30	N _{um}	[kN]	27,0	38,6	58,2	73,5	104,3	169,8	250,2	442,9
Mean ultimate loads, shear	C25/30	V _{um}	[kN]	15,4	24,4	35,4	48,4	66,0	103,0	148,3	235,7
Approved loads, tension		C12/15 ¹⁾ zul. N	[kN]	3,0	5,0	7,0	8,0	10,0	19,0	26,0	42,0
		≥ C20/25 zul. N	[kN]	7,9	11,9	15,9	12,0	19,8	29,8	35,7	60,0
Approved loads, shear		C12/15 ¹⁾ zul. V	[kN]	3,0	5,0	7,0	8,0	10,0	19,0	26,0	42,0
		≥ C20/25 zul. V	[kN]	6,0	9,2	13,3	12,0	25,2	39,4	56,8	60,0
Approved bending moments		zul. M	[Nm]	11,9	23,8	42,1	66,9	106,7	207,9	359,4	402,0

Spacing and edge distance

Effective anchorage depth	h _{ef}	[mm]	80	90	110	120	125	170	210	280
Spacing	s _{cr,N}	[mm]	240	180	220	300	250	340	420	700
Edge distance	c _{cr,N}	[mm]	120	90	110	150	125	170	210	350
Minimum spacing	s _{min}	[mm]	40	45	55	120	65	85	105	280
Minimum edge distance	c _{min}	[mm]	40	45	55	60	65	85	105	140
Minimum thickness of concrete slab	h _{min}	[mm]	110	120	140	170	160	220	260	330

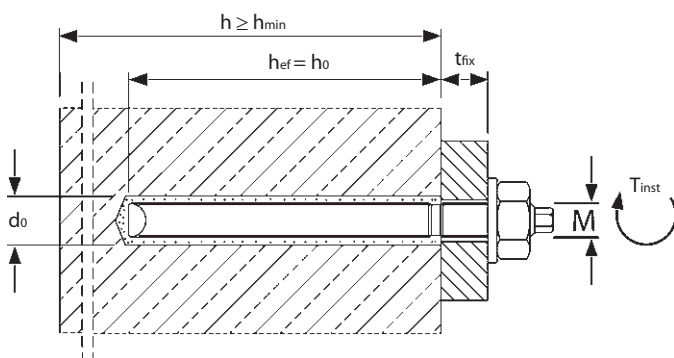
Installation parameters

Drill hole diameter	d ₀	[mm]	10	12	14	16	18	25	28	35
Clearance hole in the fixture	d _f	[mm]	9	12	14	16	18	22	26	33
Depth of drill hole	h ₀	[mm]	80	90	110	120	125	170	210	280
Installation torque	T _{inst}	[Nm]	10	20	40	60	80	120	180	400
Width across nut	SW	[mm]	13	17	19	22	24	30	36	46
Width across nut (Threaded Stud)	SW	[mm]	5	6	8	10	12	14	17	-

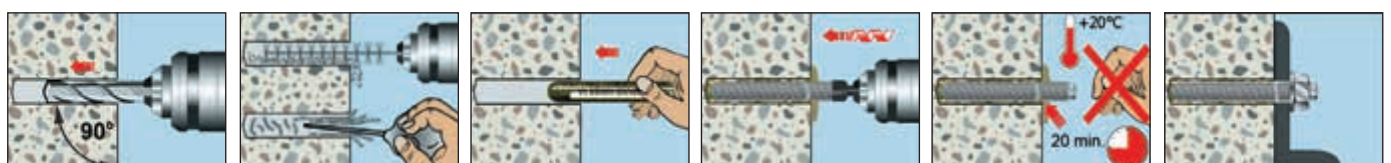
¹⁾ Not part of approval. Recommended loads for size M 14 and M 30 and in concrete C12/15.

²⁾ max long term temperature +50 °C / max short term temperature +80 °C

For anchor designing an easy to operate CD-ROM is available on request or can be downloaded at www.mkt.de.



Installation



Chemical Anchor V-IG / V-IG A4



Internally Threaded Sleeve V-IG
steel, zinc plated 5.8



Internally Threaded Sleeve V-IG A4
Stainless steel A4



Chemical Capsule V-P

Description

The Chemical Anchor system V-IG / V-IG A4 is the Internally Threaded Version of the Chemical Anchor system V. The system consists of a glass capsule and a threaded stud. The two components contained in the capsule are mixed while the threaded stud is driven in, forming a fast setting adhesive. This time proven anchoring system does not apply expansion forces and allows for very close anchor spacing and edge distances in non-cracked concrete. The drill hole is sealed by the adhesive.

- Range of loading:** 5,2 kN - 28,3 kN
- Range of concrete quality:** C12/15 - C50/60
- Material:** Steel, zinc plated
Stainless steel A4/316

Chemical Capsule V-P



→ Two component glass capsule

→ Suitable in non-cracked concrete

Description	Ref. No.	Capsule Ø mm	Capsule-length mm	Content of master box pcs.	Weight per master box kg	Package content pcs.	Weight per package kg
V-P 12	25101201	13	95	500	12,30	10	0,25
V-P 14	25101401	15	95	500	15,82	10	0,27
V-P 16	25101601	17	95	500	19,36	10	0,36
V-P 16 IG ¹⁾	25202201	22	115	-	-	10	0,98

¹⁾ For Internally Threaded Sleeve V-IG M 16.

Accessories for drill hole cleaning see page 62.



Applications

No security-relevant heavy duty anchorings in non-cracked concrete of steel supports, base plates, consoles, anti-noise barriers.

Internally Threaded Sleeve V-IG



→ Steel, zinc plated, grade 5.8

→ Fixture easy to remove; sealed drill hole

Description	Ref. No.	Suitable for capsule	Outer-Ø x Anchor length mm	Drill hole Ø x depth mm	Thread mm	Package content pcs.	Weight per package kg
V-IG M 8	24105101	V-P 12	12 x 90	14x90	M 8x25	10	0,50
V-IG M 10	24205101	V-P 14	14 x 90	16x90	M 10x30	10	0,65
V-IG M 12	24305101	V-P 16	16 x 100	18x100	M 12x35	10	1,00
V-IG M 16	24505101	V-P 16 IG	22 x 120	25x120	M 16x40	10	1,65

One setting tool is enclosed in every Internally Threaded Sleeve package.

Internally Threaded Sleeve V-IG A4



→ Stainless steel A4/316

→ Fixture easy to remove; sealed drill hole

Description	Ref. No.	Suitable for capsule	Outer-Ø x Anchor length mm	Drill hole Ø x depth mm	Thread mm	Package content pcs.	Weight per package kg
V-IG M 8 A4	24105501	V-P 12	12 x 90	14x90	M 8x25	10	0,50
V-IG M 10 A4	24205501	V-P 14	14 x 90	16x90	M 10x30	10	0,65
V-IG M 12 A4	24305501	V-P 16	16 x 100	18x100	M 12x35	10	1,00
V-IG M 16 A4	24505501	V-P 16 IG	22 x 120	25x120	M 16x40	10	1,65

One setting tool is enclosed in every Internally Threaded Sleeve package.

Recommended loads for single anchor without influence of spacing and edge distance for temperature range -40 °C to +80 °C¹⁾.
Total safety factor as per ETAG 001 included (γ_M and γ_p).

Loads and performance data	Chemical Anchor V-IG	M 8		M 10		M 12		M 16	
		non-cracked concrete C20/25							
		steel 5.8	A4-70	steel 5.8	A4-70	steel 5.8	A4-70	steel 5.8	A4-70
Mean ultimate loads, tension	N_{um} [kN]	20,4	46,7	31,9	54,6	46,2	77,4	86,4	96,8
Mean ultimate loads, shear	V_{um} [kN]	12,1	15,5	19,1	24,4	27,8	35,4	51,7	65,8
Recommended loads, tension	rec. N [kN]	8,8	9,9	13,2	13,2	16,0	16,0	18,8	18,8
Recommended loads, shear	rec. V [kN]	5,2	5,9	8,3	9,3	12,0	13,5	22,4	25,1
Recommended bending moments	rec. M [Nm]	10,7	12,1	21,4	24,1	37,4	41,9	94,9	107,0
Spacing and edge distance									
Effective anchorage depth	h_{ef} [mm]	90		90		100		120	
Characteristic spacing	$s_{cr,N}$ [mm]	225		225		250		480	
Characteristic edge distance	$c_{cr,N}$ [mm]	115		115		125		240	
Minimum spacing	s_{min} [mm]	45		45		50		75	
Minimum edge distance	c_{min} [mm]	45		45		50		75	
Minimum thickness of concrete slab	h_{min} [mm]	140		160		180		260	
Installation parameters									
Drill hole diameter	d_o [mm]	14		16		18		25	
Clearance hole in the fixture	d_f [mm]	9		12		14		18	
Depth of drill hole	h_1 [mm]	90		90		100		120	
Installation torque	$\leq T_{inst}$ [Nm]	10		20		40		80	

¹⁾ max long term temperature +50 °C / max short term temperature +80 °C

Curing Time Chemical Anchor V-IG

→ Capsule temperature when installing min. +5°

Temperature (°C) of the base material	Curing time	
	dry concrete	wet concrete
-5°C	5:00 h	10:00 h
0°C	5:00 h	10:00 h
+5°C	1:00 h	2:00 h
+10°C	1:00 h	2:00 h
+20°C	20 min	40 min
+30°C	10 min	20 min
+35°C	10 min	20 min

Injection System VMU



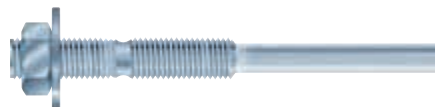
Threaded Stud VMU-A
for concrete and brickwork



Internally Threaded Sleeve VMU-IG
for concrete and brickwork



Threaded Stud VM-A
1 meter length, to be cut to the required length



Threaded Stud VMU-AH
for perforated brick with perfo sleeve



Internally Threaded Sleeve VMU-IGH
for perforated brick with perfo sleeve



Perfo Sleeve VMU-SH
for perforated brick



Cartridge VMU 150
suitable for silicone guns
Content: 150ml



Cartridge VMU 280
suitable for silicone guns
Content: 280ml, including 2 mixers, attached to the cartridge



Cartridge VMU 300
suitable for silicone guns
Content: 300ml



Cartridge VMU 345
Side-by-side cartridge
Content: 345ml



Cartridge VMU 420
Coaxial cartridge
Content: 420ml

Range of loading: 0,3 kN - 105,2 kN

Concrete quality: C20/25 - C50/60

Brickwork: Solid and perforated brick

Material: Steel zinc plated, hot dip galvanized, Stainless steel A4/316

On request: Stainless steel HCR

Description

The Injection System VMU (ETA option 7) is a chemical fastening system for non-cracked concrete. It consists of a styrene-free vinyl ester resin plus an attached hardening agent contained in a cartridge to be used with a threaded stud VMU-A, an internally threaded sleeve VMU-IG or a threaded stud V-A (see pages 61). By means of the dispenser gun VM-P the components are injected through the mixer nozzle into the drill hole. The threaded stud is inserted manually into the drill hole. The hardened injection adhesive gives a secure fastening to the base material.

Advantages:

- approved in non-cracked concrete, sizes M8 to M30.
- approved for solid and perforated brickwork
- threaded Studs V-A (pages 51) are also covered by the approval.
- approved with standard threaded studs (strength test required)
- with fire approval (loads see page 105).
- no load reduction for wet or water-filled drill holes
- opened cartridges can be re-used with a new mixer nozzle
- VMU 300 express with shorter curing time during the cold season
- styrene-free
- sealed drill hole

Applications

Fastenings in non-cracked concrete:

Baseplates, fastenings to walls and columns, joint tapes

Fastenings in masonry:

Canopies, door and window frames, facade substructures, battens



Cartridge VMU 280 express
suitable for silicone guns
Content: 280ml



Cartridge VMU 345 express
suitable for silicone guns
Content: 345ml

Injection Cartridge VMU



- Two component cartridge, styrene-free
- Approved for non-cracked concrete and brickwork

Description	Ref. No.	Content ml	Content of master box pcs	Weight per master box kg	Weight per piece kg
Cartridge VMU 150	28255261	150	12	4,20	0,34
Cartridge VMU 280 ¹⁾	28252501	280	12	6,70	0,56
Cartridge VMU 280 express	28252502	280	12	6,70	0,56
Cartridge VMU 300	28255140	300	12	6,40	0,53
Cartridge VMU 345	28255371	345	12	8,00	0,65
Cartridge VMU 345 express	28255380	345	12	8,00	0,65
Cartridge VMU 420	28257001	420	12	10,1	0,83
Static mixer VM-X (for all cartridges)	28305111	-	12	0,12	0,01
Static mixer VM-XP (only for 420ml cartridge)	28304920	-	10	0,10	0,01
Mixer extension VM-XE (200mm)	28306011	-	12	-	0,01

One static mixer VM-X as well as one screw-on cap comes with each cartridge.
¹⁾Cartridge VMU 280 (not VMU 280 express) comes with 2 mixers.

Stock-Box



- In stackable multi-purpose container
- Stock-Box, the container for various items

Description	Ref. No.	Contents	Quantity pcs.	Weight per Box kg
Stock-Box VMU 300	28999166	Cartridge VMU 300 Static mixer VM-X	20 40	15,3
Stock-Box VMU 345	28999157	Cartridge VMU 345 Static mixer VM-X	20 40	15,3
Stock-Box VMU 420	28999195	Cartridge VMU 420 Static mixer VM-XP	20 40	18,0

Dimensions Stock-Box

Description	Height mm	Width mm	Depth mm
Stock-Box	220	400	300

Curing Time Injection Adhesive VMU

- Cartridge temperature when installing min. +5°C

Temperature (°C) of the base materia	Gel time	Curing time	
		dry base material	wet base material
-5°C	1:30 h	5:30 h	11:00 h ¹⁾
-4°C to -1°C	45 min	5:30 h	11:00 h ¹⁾
0°C to +4°C	20 min	3:00 h	6:00 h
+5°C to +9°C	12 min	2:00 h	4:00 h
+10°C to +19°C	6 min	1:20 h	2:40 h
+20°C to +29°C	4 min	45 min	1:30 h
+30°C to +34°C	2 min	25 min	50 min
+35°C to +39°C	1,4 min	20 min	40 min
+40°C	1,4 min	15 min	30 min

¹⁾It must be ensured that icing does not occur in the drill hole. The hole must be drilled and cleaned directly prior to the installation of the anchor.

Curing Time Injection Adhesive VMU express

- Cartridge temperature when installing min. +5°C

Temperature (°C) of the base material	Gel time	Curing time	
		dry base material	wet base material
-5°C	40 min	4:00 h	8:00 h ¹⁾
-4°C to -1°C	20 min	4:00 h	8:00 h ¹⁾
0°C to +4°C	10 min	2:00 h	4:00 h
+5°C to +9°C	6 min	1:00 h	2:00 h
+10°C to +19°C	3 min	40 min	80 min
+20°C to +29°C	1 min	20 min	40 min

¹⁾It must be ensured that icing does not occur in the drill hole. The hole must be drilled and cleaned directly prior to the installation of the anchor.



Threaded Studs for applications in concrete

Threaded Stud VMU-A

Steel, zinc plated 5.8



- May be used in structures subject to dry internal conditions
- Approved for non-cracked concrete
- Steel, zinc plated grade 8.8 on demand or as threaded studs, 1 meter length, (see page 75)



Description	Ref. No.	Drill hole Ø x depth mm	Maximum Fixture thickness t _{fix} mm	Pkg. cont. pcs.	Weight per pkg. kg
VMU-A 8-10/100	31510101	10 x 80	10	10	0,42
VMU-A 8-20/110	31515101	10 x 80	20	10	0,46
VMU-A 8-40/130	31525101	10 x 80	40	10	0,52
VMU-A 8-55/145	31528101	10 x 80	55	10	0,55
VMU-A 8-70/160	31530101	10 x 80	70	10	0,60
VMU-A 8-115/205	31550101	10 x 80	115	10	0,74
VMU-A 10-10/110	31605101	12 x 90	10	10	0,75
VMU-A 10-30/130	31625101	12 x 90	30	10	0,85
VMU-A 10-50/150	31630101	12 x 90	50	10	0,95
VMU-A 10-65/165	31635101	12 x 90	65	10	1,02
VMU-A 10-90/190	31645101	12 x 90	90	10	1,15
VMU-A 10-160/260	31655101	12 x 90	160	10	1,50
VMU-A 12-10/135	31710101	14 x 110	10	10	1,25
VMU-A 12-30/155	31720101	14 x 110	30	10	1,42
VMU-A 12-50/175	31730101	14 x 110	50	10	1,54
VMU-A 12-85/210	31740101	14 x 110	85	10	1,82
VMU-A 12-125/250	31750101	14 x 110	125	10	2,13
VMU-A 12-175/300	31760101	14 x 110	175	10	2,5
VMU-A 16-15/160	31810101	18 x 125	15	10	2,65
VMU-A 16-30/175	31815101	18 x 125	30	10	2,85
VMU-A 16-60/205	31820101	18 x 125	60	10	3,25
VMU-A 16-90/235	31830101	18 x 125	90	10	3,65
VMU-A 16-155/300	31840101	18 x 125	155	10	4,53
VMU-A 20-50/240	31910101	22 x 170	50	10	5,85
VMU-A 20-70/260	31915101	22 x 170	70	10	6,30
VMU-A 20-95/285	31920101	22 x 170	95	10	6,75
VMU-A 20-115/305	31925101	22 x 170	115	10	7,15
VMU-A 20-160/350	31930101	22 x 170	160	10	8,10
VMU-A 20-210/400	31935101	22 x 170	210	10	9,10
VMU-A 24-55/290	31960101	26 x 210	55	5	4,95
VMU-A 24-115/350	31965101	26 x 210	115	5	5,85
VMU-A 24-165/400	31970101	26 x 210	165	5	6,60
VMU-A 30-70/370	31990101	32 x 270	70	5	9,90

Threaded Stud VMU-A A4

Stainless steel A4 / 316



- May be used in structures subject to dry internal conditions or to external atmospheric exposure
- Approved for non-cracked concrete
- Stainless steel HCR (1.4529) on demand

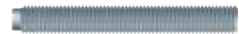


Description	Ref. No.	Drill hole Ø x depth mm	Maximum Fixture thickness t _{fix} mm	Pkg. cont. pcs.	Weight per pkg. kg
VMU-A 8-10/100 A4	31510501	10 x 80	10	10	0,42
VMU-A 8-20/110 A4	31515501	10 x 80	20	10	0,46
VMU-A 8-40/130 A4	31525501	10 x 80	40	10	0,52
VMU-A 8-55/145 A4	31528501	10 x 80	55	10	0,55
VMU-A 8-70/160 A4	31530501	10 x 80	70	10	0,60
VMU-A 8-115/205 A4	31550501	10 x 80	115	10	0,74
VMU-A 10-10/110 A4	31605501	12 x 90	10	10	0,75
VMU-A 10-30/130 A4	31625501	12 x 90	30	10	0,85
VMU-A 10-50/150 A4	31630501	12 x 90	50	10	0,95
VMU-A 10-65/165 A4	31635501	12 x 90	65	10	1,02
VMU-A 10-90/190 A4	31645501	12 x 90	90	10	1,15
VMU-A 10-160/260 A4	31655501	12 x 90	160	10	1,50
VMU-A 12-10/135 A4	31710501	14 x 110	10	10	1,25
VMU-A 12-30/155 A4	31720501	14 x 110	30	10	1,42
VMU-A 12-50/175 A4	31730501	14 x 110	50	10	1,54
VMU-A 12-85/210 A4	31740501	14 x 110	85	10	1,82
VMU-A 12-125/250 A4	31750501	14 x 110	125	10	2,13
VMU-A 12-175/300 A4	31760501	14 x 110	175	10	2,50
VMU-A 16-15/160 A4	31810501	18 x 125	15	10	2,65
VMU-A 16-30/175 A4	31815501	18 x 125	30	10	2,85
VMU-A 16-60/205 A4	31820501	18 x 125	60	10	3,25
VMU-A 16-90/235 A4	31830501	18 x 125	90	10	3,65
VMU-A 16-155/300 A4	31840501	18 x 125	155	10	4,53
VMU-A 20-50/240 A4	31910501	22 x 170	50	10	5,85
VMU-A 20-70/260 A4	31915501	22 x 170	70	10	6,30
VMU-A 20-95/285 A4	31920501	22 x 170	95	10	6,75
VMU-A 20-115/305 A4	31925501	22 x 170	115	10	7,15
VMU-A 24-55/290 A4	31960501	26 x 210	55	5	4,95
VMU-A 24-115/350 A4	31965501	26 x 210	115	5	5,85
VMU-A 24-165/400 A4	31970501	26 x 210	165	5	6,60
VMU-A 30-70/370 A4	31990501	32 x 270	70	5	9,90

Internally Threaded Sleeve

VMU-IG¹⁾

Steel, zinc plated 5.8



- May be used in structures subject to dry internal conditions
- For non-cracked concrete

Description	Ref. No.	Drill hole Ø x depth mm	Outer-Ø x anchor length mm	Thread depth min s / max s mm	Package content pcs.	Weight per pkg. kg
VMU-IG M6	31500101	12 x 98	10 x 93	8 / 20	10	0,65
VMU-IG M8	31560101	14 x 98	12 x 93	8 / 20	10	0,95

¹⁾ VMU-IG is not part of the approval ETA-05/0253.

Internally Threaded Sleeve

VMU-IG A4¹⁾

Stainless steel A4 / 316



- May be used in structures subject to dry internal conditions or to external atmospheric exposure
- For non-cracked concrete

Description	Ref. No.	Drill hole Ø x depth mm	Outer-Ø x anchor length mm	Thread depth min s / max s mm	Package content pcs.	Weight per pkg. kg
VMU-IG M6 A4	31500501	12 x 98	10 x 93	8 / 20	10	0,65
VMU-IG M8 A4	31560501	14 x 98	12 x 93	8 / 20	10	0,95

¹⁾ VMU-IG is not part of the approval ETA-05/0253.

Threaded Stud V-A

see page 61



- Steel, zinc plated or hot dip galvanized grade 5.8
- Stainless steel A4 / 316
- Stainless steel HCR (1.4529) on demand

Threaded Stud VM-A

see page 75



- Steel, zinc plated grade 5.8 or 8.8
- Stainless steel A4 / 316
- Threaded studs, of 1 meter length, to be cut to the required length, with manufacturer's certificate

Threaded Studs for applications in solid and hollow base material

**Threaded Stud VMU-A
Threaded Stud VMU-AH**

Steel, zinc plated 5.8
Stainless steel A4 / 316

- Threaded Stud VMU-A approved for solid base material and hollow base material with perfo sleeve
- Threaded Stud VMU-AH approved for hollow base material with perfo sleeve
- Steel hot dip galvanized and stainless steel HCR (1.4529) on demand



Description	Steel, zinc plated 5.8	Stainless steel A4 / 316	Maximum Fixture thickness t _{fix} mm	Solid base material		Solid and hollow base material		Pkg. cont. pcs.	Weight per pkg. kg
	Ref. No.	Ref. No.		Drill hole Ø x depth mm	perfo sleeve	Drill hole Ø x depth mm			
VMU-A 8-10/100	31510101	31510501	10	10 x 85	VMU-SH 14x100	14 x 105	10	0,42	
VMU-A 8-20/110	31515101	31515501	20	10 x 85	VMU-SH 14x100	14 x 105	10	0,46	
VMU-A 8-40/130	31525101	31525501	40	10 x 85	VMU-SH 14x100	14 x 105	10	0,52	
VMU-A 8-55/145	31528101	31528501	55	10 x 85	VMU-SH 14x100	14 x 105	10	0,55	
VMU-A 8-70/160	31530101	31530501	70	10 x 85	VMU-SH 14x100	14 x 105	10	0,60	
VMU-A 8-115/205	31550101	31550501	115	10 x 85	VMU-SH 14x100	14 x 105	10	0,74	
VMU-A 10-10/110	31605101	31605501	10	12 x 95	VMU-SH 16x100	16 x 105	10	0,75	
VMU-A 10-30/130	31625101	31625501	30	12 x 95	VMU-SH 16x100	16 x 105	10	0,85	
VMU-A 10-50/150	31630101	31630501	50	12 x 95	VMU-SH 16x100	16 x 105	10	0,95	
VMU-A 10-65/165	31635101	31635501	65	12 x 95	VMU-SH 16x100	16 x 105	10	1,02	
VMU-A 10-90/190	31645101	31645501	90	12 x 95	VMU-SH 16x100	16 x 105	10	1,15	
VMU-A 10-160/260	31655101	31655501	160	12 x 95	VMU-SH 16x100	16 x 105	10	1,50	
VMU-A 12-15/120	31717101	31717501	15	14 x 98	not suitable for hollow base material		10	1,14	
VMU-A 12-25/130	31718101	31718501	25	14 x 98	not suitable for hollow base material		10	1,21	
VMU-A 12-50/155	31732101	31732501	50	14 x 98	not suitable for hollow base material		10	1,42	
VMU-A 12-80/185	31734101	31734501	80	14 x 98	not suitable for hollow base material		10	1,63	
VMU-A 12-120/225	31748101	31748501	120	14 x 98	not suitable for hollow base material		10	1,89	
VMU-A 12-160/265	31757101	31757501	160	14 x 98	not suitable for hollow base material		10	2,18	
VMU-AH 12-15/120	31302181	31302581	15	-	VMU-SH 16x100	16 x 105	10	0,92	
VMU-AH 12-25/130	31304181	31304581	25	-	VMU-SH 16x100	16 x 105	10	0,99	
VMU-AH 12-50/155	31306181	31306581	50	-	VMU-SH 16x100	16 x 105	10	1,18	
VMU-AH 12-80/185	31310181	31310581	80	-	VMU-SH 16x100	16 x 105	10	1,38	
VMU-AH 12-120/225	31312181	31312581	120	-	VMU-SH 16x100	16 x 105	10	1,68	
VMU-AH 12-160/265	31315181	31315581	160	-	VMU-SH 16x100	16 x 105	10	1,97	

Internally Threaded Sleeve VMU-IG

Steel, zinc plated 5.8
Stainless steel A4 / 316

- With internal thread
- Approved for solid base material without perfo sleeve



Description	Steel, zinc plated 5.8	Stainless steel A4 / 316	Drill hole Ø x depth	Outer-Ø x anchor length	Thread depth min s / max s	Package content pcs.	Weight per pkg. kg
	Ref. No.	Ref. No.	mm	mm	mm	pcs.	kg
VMU-IG M6	31500101	31500501	12 x 98	10 x 93	8 / 20	10	0,65
VMU-IG M8	31560101	31560501	14 x 98	12 x 93	8 / 20	10	0,95

Internally Threaded Sleeve VMU-IGH

Steel, zinc plated 5.8
Stainless steel A4 / 316

- With internal thread
- Approved for solid and hollow base material with perfo sleeve



Description	Steel, zinc plated 5.8	Stainless steel A4 / 316	Drill hole Ø x depth	Outer-Ø x anchor length	Thread depth min s / max s	Package content pcs.	Weight per pkg. kg
	Ref. No.	Ref. No.	mm	mm	mm	pcs.	kg
VMU-IGH M 6	31060111	31060511	16x105	12 x 93	8 / 20	10	0,39
VMU-IGH M 8	31160111	31160511	16x105	12 x 93	8 / 20	10	0,39

Perfo Sleeve VMU-SH



- Polypropylene
- Approved for solid and hollow base material

Description	Ref. No.	Drill hole Ø x depth mm	suitable for threaded studs	internally threaded sleeves	Package content pcs.	Weight per pkg. kg
VMU-SH 14x100	28171301	14x105	M8		10	0,03
VMU-SH 16x100	28171501	16x105	M10-M12	IGH M6-M8	10	0,04

Cleaning Brush RB M6



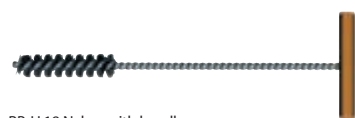
RB M6, with connection thread M6



RBL M6, with internal and external thread M6



RBL M6 SDS, with internal thread M6



RB-H 18 Nylon, with handle

Blow-out pump VM-AP



Air gun VM-ABP



Dispenser VM-P Profi



Dispenser VM-P Standard



Dispenser VM-P Pneumatic



→ With connection thread M6 – extension for large depths of drill hole and/or for through-setting installation

→ For drilling machines with keyed chuck or with SDS adaptor for SDS plus drills

Description	Ref. No.	Suitable for drill hole Ø mm	Total length of brush mm	Base material	Suitable for		Pkg. cont. pcs	Weight per piece kg	
					Threaded stud	Internally threaded sleeve			
RB 10 M6	33510101	10	130	concrete	VMU-A M8	-	1	0,05	
RB 12 M6	33512101	12	140	concrete	VMU-A M10	VMU-IG M6	1	0,05	
RB 14 M6	33514101	14	180	concrete	VMU-A M12	VMU-IG M8	1	0,05	
RB 18 M6	33518101	18	200	concrete	VMU-A M16	-	1	0,05	
RB 22 M6	33522101	22	220	concrete	VMU-A M20	-	1	0,05	
RB 26 M6	33526101	26	290	concrete	VMU-A M24	-	1	0,06	
RB 32 M6	33532101	32	350	concrete	VMU-A M30	-	1	0,06	
RBL M6	33968101	Brush extension 150mm with connection thread M6						1	0,09
RBL M6 SDS	33350101	SDS Plus adapter with internal thread M6						1	0,06

→ Drill hole cleaning in solid and hollow base material

Description	Ref. No.	Suitable for drill hole Ø mm	length of brush	Base material	Suitable for		Pkg. cont. pcs	Weight per piece kg
					Threaded stud	Int. threaded sleeve		
RB-H 18/280	29918501	10-16	250	brickwork	all	all	1	0,04
RB-H 18/400	33618101	10-16	400	brickwork	all	all	1	0,05

→ Drill hole cleaning for VMU-A / VMU-AH M8-M16 and VMU-IG / VMU-IGH M6-M8

Description	Ref. No.	Suitable for maximum depth of drill hole mm	Pkg. cont. pcs	Weight per piece kg
VM-AP 360, blow-out pump	33200101	300	1	0,27

→ Drill hole cleaning with compressed air for VMU-A M20-M30

Description	Ref. No.	Suitable for maximum depth of drill hole mm	Pkg. cont. pcs	Weight per piece kg
VM-ABP 250	33100101	240	1	1,00
VM-ABP 500	33106101	480	1	1,30

→ Professional dispenser with an ideal center of gravity for more comfortable working

→ Automatic pressure release for minimum material overrun

Description	Ref. No.	Suitable for cartridge	Pkg. cont. pcs.	Weight per piece kg
VM-P 345 Profi	28350511	150ml, 280ml, 300ml, 345ml also suitable for silicone cartridges	1	1,00
VM-P 380 Profi	28351001	380ml, 410ml, 420ml	1	1,10

→ For occasional use, metal version

→ Piston rod with adjusting screw

Description	Ref. No.	Suitable for cartridge	Pkg. cont. pcs.	Weight per piece kg
VM-P 345 Standard	28350505	150ml, 280ml, 300ml, 345ml also suitable for silicone cartridges	1	1,00
VM-P 380 Standard	28353005	380ml, 410ml, 420ml	1	1,15

→ Professional air tool with an optimum center of gravity and quick cartridge exchange

→ Automatic pressure release system reduces material overrun to a minimum

→ Single-hand pressure regulation to adjust the piston speed

Description	Ref. No.	Suitable for cartridge	max. working pressure 8bar, 40l/min	Pkg. cont. pcs.	Weight per piece kg
VM-P 345 Pneumatic	28350601	345ml		1	2,41
VM-P 380 Pneumatic	28352002	380ml, 410ml, 420ml		1	2,00



Extract from Permissible Service Conditions of ETA-05/0253.

Approved loads for single anchor without influence of spacing and edge distance for temperature range -40°C to +80 °C¹⁾.
 Total safety factor as per ETAG 001 included (γ_M and γ_P).

Loads and performance data	Injection System VMU with threaded stud VMU-A steel, zinc plated / hot dip galvanized in concrete			M8	M 10	M 12	M 16	M20	M24	M30
				non-cracked concrete						
Mean ultimate loads, tension ²⁾	C25/30	N _{um}	[kN]	33,7	56,2	71,1	89,9	181,0	220,0	338,0
Mean ultimate loads, shear ³⁾	C25/30	V _{um}	[kN]	11,0	17,5	25,4	47,5	74,0	116,5	185,0
Approved loads, tension (steel 5.8)	C20/25	appr. N	[kN]	7,6	11,9	16,7	23,8	45,2	54,8	81,0
	C25/30	appr. N	[kN]	8,1	12,6	17,7	25,2	48,0	58,0	85,8
	C30/37	appr. N	[kN]	8,5	13,3	18,7	26,7	50,7	61,3	90,7
	C40/50	appr. N	[kN]	8,6	13,8	20,0	29,3	55,6	67,4	99,6
	C50/60	appr. N	[kN]	8,6	13,8	20,0	31,0	58,6	71,2	105,2
Approved loads, shear (steel 5.8)	≥ C20/25	appr. V	[kN]	5,1	8,6	12,0	22,3	34,9	50,3	80,0
Appr. bending moments (steel 5.8)		appr. M	[Nm]	10,9	21,1	37,1	94,3	185,7	320,6	642,3
Approved loads, tension (steel 8.8)	C20/25	appr. N	[kN]	7,6	11,9	16,7	23,8	45,2	54,8	81,0
	C25/30	appr. N	[kN]	8,1	12,6	17,1	25,2	48,0	58,0	85,8
	C30/37	appr. N	[kN]	8,5	13,3	18,7	26,7	50,7	61,3	90,7
	C40/50	appr. N	[kN]	9,4	14,6	20,5	29,3	55,6	67,4	99,6
	C50/60	appr. N	[kN]	9,9	15,5	21,7	31,0	58,8	71,2	105,2
Approved loads, shear (steel 8.8)	≥ C20/25	appr. V	[kN]	8,6	13,1	19,4	36,0	56,0	80,6	128,0
Appr. bending moments (steel 8.8)		appr. M	[Nm]	17,1	34,3	60,0	152,0	296,6	513,1	1028,0

Spacing and edge distance

Effective anchorage depth	h_{ef}	[mm]	80	90	110	125	170	210	270
Characteristic spacing	$s_{cr,N}$	[mm]	160	180	220	250	340	420	540
Characteristic edge distance	$c_{cr,N}$	[mm]	80	90	110	125	170	210	270
Minimum thickness of concrete slab	≥ h_{min}	[mm]	100	130	160	200	220	280	350
Red. Min. thickness of concrete slab	≥ $h_{min,red}$	[mm]	-	120	140	160	-	-	-
Minimum spacing	s_{min}	[mm]	40	45	55	65	85	105	135
Minimum edge distance	c_{min}	[mm]	40	45	55	65	85	105	135

Installation parameters

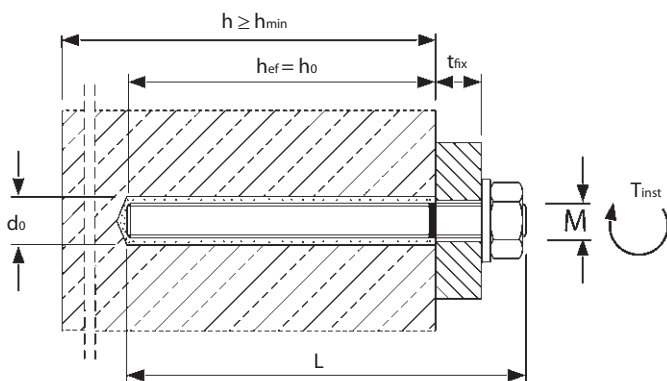
Drill hole diameter	d_o	[mm]	10	12	14	18	22	26	32
Clearance hole in the fixture	d_f	[mm]	9	12	14	18	22	26	33
Depth of drill hole	h_o	[mm]	80	90	110	125	170	210	270
Installation torque	≤ T_{inst}	[Nm]	10	20	40	60	120	150	300
Width across nut	SW	[mm]	13	17	19	24	30	36	46
Amount of mortar per drill hole		[ml]	5,2	7,3	10,8	17,1	30,4	47,0	82,0
Drill holes per cartridge VMU 150		[Quan.]	21	15	10	6	3	2	1
Drill holes per cartridge VMU 280 / VMU 300		[Quan.]	46 / 50	32 / 35	22 / 24	14 / 15	7 / 8	5 / 5	2 / 3
Drill holes per cartridge VMU 345 / VMU 420		[Quan.]	58 / 72	41 / 52	28 / 35	17 / 22	10 / 12	6 / 8	3 / 4

¹⁾ max long term temperature +50 °C / max short term temperature +80 °C

²⁾ Mean ultimate loads steel zinc plated for studs 8.8.

³⁾ Mean ultimate loads steel zinc plated for studs 5.8.

Technical data for solid and hollow base materials see page 73.



Installation





Extract from Permissible Service Conditions of ETA-05/0253.

Approved loads for single anchor without influence of spacing and edge distance for temperature range -40°C to +80 °C¹⁾.
Total safety factor as per ETAG 001 included (γ_M and γ_r).

Loads and performance data	Injection System VMU with threaded stud VMU-A stainless steel A4/316 and HCR in concrete		non-cracked concrete							
			M8	M 10	M 12	M 16	M20	M24	M30	
Mean ultimate loads, tension	C25/30	N _{um}	[kN]	33,7	56,2	71,1	89,9	181,0	220,0	338,0
Mean ultimate loads, shear	C25/30	V _{um}	[kN]	15,4	24,4	35,4	66,0	103,0	148,3	176,4
Approved loads, tension	C20/25	appr. N	[kN]	7,6	11,9	16,7	23,8	45,2	54,8	81,0/69,9 ²⁾
	C25/30	appr. N	[kN]	8,1	12,6	17,7	25,2	48,0	58,0	83,3/69,9 ²⁾
	C30/37	appr. N	[kN]	8,5	13,3	18,7	26,7	50,7	61,3	83,3/69,9 ²⁾
	C40/50	appr. N	[kN]	9,4	14,6	20,5	29,3	55,6	67,4	83,3/69,9 ²⁾
	C50/60	appr. N	[kN]	9,9	15,5	21,7	31,0	58,8	71,2	83,3/69,9 ²⁾
Approved loads, shear	≥ C20/25	appr. V	[kN]	7,4/6,0 ²⁾	11,4/9,2 ²⁾	17,1/13,7 ²⁾	31,4/25,2 ²⁾	49,1/39,4 ²⁾	70,3/56,3 ²⁾	50,0/42,0 ²⁾
Appr. bending moments		appr. M	[Nm]	14,9/11,9 ²⁾	29,7/23,8 ²⁾	52,6/42,1 ²⁾	133,1/106,7 ²⁾	259,4/207,9 ²⁾	448,0/359,0 ²⁾	401,1/337,0 ²⁾

Spacing and edge distance

Effective anchorage depth	h_{ef}	[mm]	80	90	110	125	170	210	270
Characteristic spacing	$s_{cr,N}$	[mm]	160	180	220	250	340	420	540
Characteristic edge distance	$c_{cr,N}$	[mm]	80	90	110	125	170	210	270
Minimum thickness of concrete slab	≥ h_{min}	[mm]	100	130	160	200	220	280	350
Red. Min. thickness of concrete slab	≥ $h_{min,red}$	[mm]	-	120	140	160	-	-	-
Minimum spacing	s_{min}	[mm]	40	45	55	65	85	105	135
Minimum edge distance	c_{min}	[mm]	40	45	55	65	85	105	135

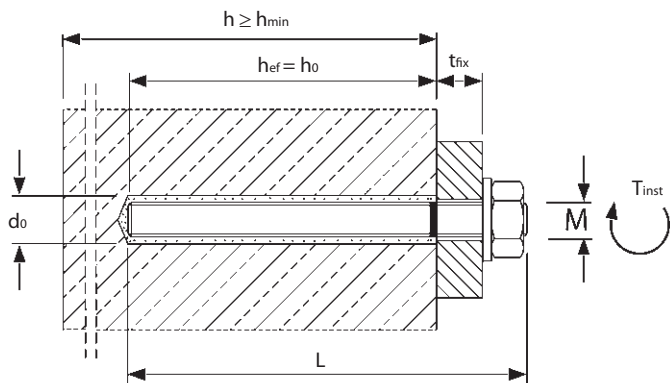
Installation parameters

Drill hole diameter	d_o	[mm]	10	12	14	18	22	26	32
Clearance hole in the fixture	d_f	[mm]	9	12	14	18	22	26	33
Depth of drill hole	h_o	[mm]	80	90	110	125	170	210	270
Installation torque	≤ T_{inst}	[Nm]	10	20	40	60	120	150	300
Width across nut	SW	[mm]	13	17	19	24	30	36	46
Amount of mortar per drill hole		[ml]	5,2	7,3	10,8	17,1	30,4	47,0	82,0
Drill holes per cartridge VMU 150		[Quan.]	21	15	10	6	3	2	1
Drill holes per cartridge VMU 280 / VMU 300		[Quan.]	46 / 50	32 / 35	22 / 24	14 / 15	7 / 8	5 / 5	2 / 3
Drill holes per cartridge VMU 345 / VMU 420		[Quan.]	58 / 72	41 / 52	28 / 35	17 / 22	10 / 12	6 / 8	3 / 4

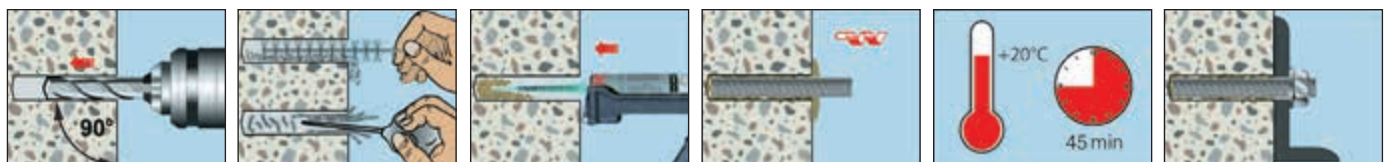
¹⁾ max long term temperature +50 °C / max short term temperature +80 °C

²⁾ commercial threaded rod with stress analysis

For anchor designing an easy to operate CD-ROM is available on request or can be downloaded at www.mkt.de.



Installation





Extract from Permissible Service Conditions of Z-21.3-1803

Approved loads for single anchor without influence of spacing and edge distance.
Total safety factor as per ETAG 001 included (γ_M and γ_p).⁶⁾

Loads and performance data	Injection System VMU with threaded stud VMU-A/AH/IG/IGH steel z.p. / s.s. A4 /316 / s.s. HCR in masonry			VMU-A		VMU-AH	VMU-IG/VMU-IGH	
		M 8	M 10	M 12	M 12	M 6	M 8	
Approved bending moments (Steel, zinc plated 5.8)	appr. M [Nm]	11,0	21,0	37,0	37,0	4,4	11,0	
Approved bending moments (Stainless steel A4/316)	appr. M [Nm]	12,0	24,0	42,0	42,0	4,9	12,0	
App. bending moments (Stainless steel HCR 1.4529)	appr. M [Nm]	9,4	19,0	33,0	33,0	4,9	9,4	

Spacing and edge distance

Effective anchorage depth	h_{ef}	[mm]	80	90	93	93	93	93
Spacing (Anchor group) ¹⁾	$a \geq$	[mm]			100 (200) ²⁾			
Minimum spacing	$min\ a$	[mm]			50 ³⁾			
Spacing (single anchor)	a_z	[mm]			250			
Edge distance	$a_r \geq$	[mm]			200 (250) ⁴⁾			
Edge distance for special applications	a_r	[mm]			50 (60) ⁴⁾			
Minimum thickness of base material (masonry)	h_{min}	[mm]			110			

Installation parameters

Thread length of screw/threaded stud	$min\ s$	[mm]	-	-	-	-	8	8
	$max\ s$	[mm]	-	-	-	-	20	20
Diameter of drill hole with perfo sleeve	d_o	[mm]	14	16	-	16	16	16
Dia. of drill hole without perfo sleeve (solid base material)	d_o	[mm]	10	12	14	-	12	14
Clearance hole in the fixture	d_r	[mm]	9	12	14	14	7	9
Depth of drill hole with perfo sleeve	h_{i0}	[mm]	105	105	-	105	105	105
Depth of drill hole without perfo sleeve	h_o	[mm]	85	95	98	-	98	98
Installation torque	$\leq T_{inst}$	[Nm]	8 ⁵⁾	8 ⁵⁾	8 ⁵⁾	8 ⁵⁾	8 ⁵⁾	8 ⁵⁾
Diameter cleaning brush RB-H 18	d_b	[mm]	18	18	18	18	18	18
Amount of mortar per drill hole with perfo sleeve	[ml]		15,0	21,0	-	21,0	21,0	21,0
Amount of mortar per drill hole without perfo sleeve	[ml]		5,2	7,3	9,8	-	7,3	9,8
Drill holes per cartridge with perfo sleeve VMU 150 / 280 / 300	[Quan.]		7 / 16 / 17	5 / 11 / 12	-	5 / 11 / 12	5 / 11 / 12	5 / 11 / 12
Drill holes per cartridge with perfo sleeve VMU 345 / 420	[Quan.]		20 / 25	14 / 18	-	14 / 18	14 / 18	14 / 18
Drill holes per cart. without perfo sleeve VMU 150 / 280 / 300	[Quan.]		21 / 46 / 50	15 / 32 / 35	11 / 24 / 26	-	15 / 32 / 35	11 / 24 / 26
Drill holes per cart. without perfo sleeve VMU 345 / 420	[Quan.]		58 / 73	41 / 52	31 / 38	-	41 / 52	31 / 38

¹⁾ For reduced spacing, please view approval Z-21.3-1803.

²⁾ Value in brackets for Hbl (Hollow block concrete, according to DIN 18151) and Hbn (Hollow block concrete, DIN 18153).

³⁾ min a not valid for Hbl and Hbn brickwork.

⁴⁾ Value in brackets valid for solid brick.

⁵⁾ 2 Nm if anchor plate is not seated solidly on surface of base material.

⁶⁾ max. long term temperature +50°C / max. short term temperature +80°C.

Approved loads in masonry for all load directions

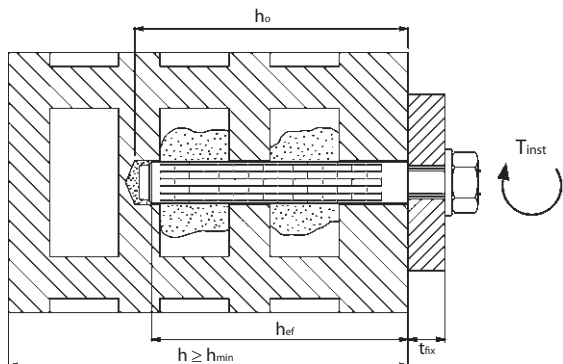
	[kN]	Solid brick		Vertical perforated brick			Sand-lime perforated brick			Hollow block lightw. concrete		Hollow block concrete
		Mz 12	KS 12	HLz 4	HLz 6	HLz 12	KSL 4	KSL 6	KSL 12	Hbl 2	Hbl 4	Hbn 4
Drilling with rotation only	[kN]	1,7	1,7	0,6	0,8	1,0	0,6 ¹⁾	0,8 ¹⁾	1,4 ¹⁾	0,5	0,8	0,8
Drilling with hammer action	[kN]	1,7	1,7	0,3	0,4	0,8	0,4	0,6	0,8	0,3	0,6	0,6

¹⁾ Outer web $\geq 30mm$

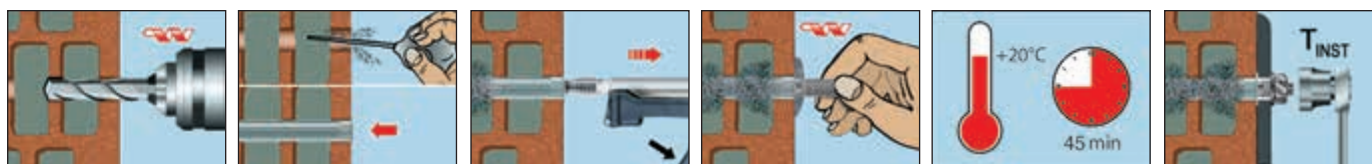
Maximum load for single brick

		$\leq 3\ DF^{1)}$	4 to 10 $DF^{1)}$	$\geq 10\ DF^{1)}$
Unburdened masonry max. F	[kN]	1,0	1,4	2,0
Burdened masonry max. F	[kN]	1,4	1,7	2,5





¹⁾ Dimension of brick acc. to DIN-Standard



Installation



Injection System VME

-  **Threaded Stud V-A**
-  **Threaded Stud VMU-A**
-  **Threaded Stud VM-A**
1 meter length, to be cut to the required length
-  **Reinforcement Bars BSt 500 S**

-  **Cartridge VME 385**
Side-by-side cartridge
Content: 385ml

-  **Cartridge VME 585**
Side-by-side cartridge
Content: 585ml

-  **Cartridge VME 1400**
Side-by-side cartridge
Content: 1400ml

Range of loading: 3,1 - 128 kN

Concrete quality: C20/25 - C50/60

Material: Steel zinc plated, hot dip galvanized, Stainless steel A4/316, Stainless steel HCR, BSt 500 S

Description

The Injection System VME is an approved system for fixings of threaded studs or reinforcement bars in cracked and non-cracked concrete. In the cartridge, the epoxy resin and the hardener are separated. By means of the dispenser gun VM-P the components are pushed through the mixer nozzle, activated and injected into the drill hole. The Injection System VME can be used with the threaded Studs V-A (see pages 61) and VMU-A (see page 68). It can also be used with VM-A studs, sold by meter to be cut to the required length or with standard reinforcement bars.



Applications

Fixing of rack systems, railings, steel structures, noise barriers, stairs and machines.
Subsequent closure of wall and ceiling openings, reinforcement of existing concrete structures, installation of reinforcement for the connection of the following concrete components (if the installation of reinforcement was missed or not possible because of the working process), connection of steel structures.

Advantages:

- approved in cracked and non-cracked concrete
- approved with threaded studs and reinforcement bars
- approved with standard threaded studs (strength test required)
- also approved for post-installed rebar connections according to ETA-07/0299 / Z-21.8-1872 (see page 79)
- variable anchorage depth for less drilling efforts
- long curing times for an economic working process with serial installations and/or large drill holes
- suitable for dry and wet concrete and in water-filled drill holes
- styrene-free

Injection Cartridge VME



- Very high loads
- no shrinkage

Description	Ref. No.	Content ml	Content of master box pcs	Weight per master box kg	Weight per piece kg
Cartridge VME 385	28255501	385	12	8,5	0,70
Cartridge VME 585	28255601	585	12	12,09	0,98
Cartridge VME 1400	28255701	1400	5	12,34	2,40
Static mixer VM-XL ¹⁾	28305201	-	10	0,28	0,03
Static mixer VM-X ²⁾	28305111	-	12	0,12	0,01

One static mixer VM-XL as well as one screw-on cap comes with each cartridge.

¹⁾ Static mixer VM-XL suitable for drill hole diameter of 12mm and bigger.

²⁾ Static mixer VM-X only required for drill hole diameter of 10mm (special accessories).

Threaded Stud for Injection System VME

Threaded Stud V-A see page 61



- Steel, zinc plated or hot dip galvanized grade 5.8
- Stainless steel A4 / 316
- Stainless steel HCR (1.4529) on demand

Threaded Stud VMU-A see page 68



- Steel, zinc plated grade 5.8
- Stainless steel A4 / 316
- Stainless steel HCR (1.4529) on demand

Threaded Stud VM-A Steel, zinc plated grade 5.8



- Threaded studs, of 1 meter length, to be cut to the required length
- Comes with manufacturer's certificate (3.1 EN 10204) in every package

Description	Ref. No.	Drill hole Ø mm	Thread	Length mm	Pkg. cont. pcs.	Weight per pkg. kg
VM-A 8x1000 ¹⁾	31199101	10	M8	1000	10	3,91
VM-A 10x1000	31299101	12	M10	1000	10	5,5
VM-A 12x1000	31399101	14	M12	1000	10	7,76
VM-A 16x1000	31599101	18	M16	1000	10	13,6
VM-A 20x1000	31699101	24	M20	1000	5	10,8
VM-A 24x1000	31799101	28	M24	1000	5	15,35

Threaded Stud VM-A Steel, zinc plated 8.8



- Threaded studs, of 1 meter length, to be cut to the required length
- Comes with manufacturer's certificate (3.1 EN 10204) in every package

Description	Ref. No.	Drill hole Ø mm	Thread	Length mm	Pkg. cont. pcs.	Weight per pkg. kg
VM-A 8x1000 8.8 ¹⁾	31199181	10	M8	1000	10	3,91
VM-A 10x1000 8.8	31299181	12	M10	1000	10	5,5
VM-A 12x1000 8.8	31399181	14	M12	1000	10	7,76
VM-A 16x1000 8.8	31599181	18	M16	1000	10	13,6

Threaded Stud VM-A Stainless steel A4 / 316



- Threaded studs, of 1 meter length, to be cut to the required length
- Comes with manufacturer's certificate (3.1 EN 10204) in every package

Description	Ref. No.	Drill hole Ø mm	Thread	Length mm	Pkg. cont. pcs.	Weight per pkg. kg
VM-A 8x1000 A4 ¹⁾	31199501	10	M8	1000	10	3,77
VM-A 10x1000 A4	31299501	12	M10	1000	10	5,43
VM-A 12x1000 A4	31399501	14	M12	1000	10	8,03
VM-A 16x1000 A4	31599501	18	M16	1000	10	13,95
VM-A 20x1000 A4	31699501	24	M20	1000	5	11,0
VM-A 24x1000 A4	31799501	28	M24	1000	5	15,6

¹⁾ For drill hole diameter of 10mm static mixer VM-X is required. Please order separately (special accessories).

Installation



Injecting equipment

Retaining Washer

- For bubble-free filling of the drill hole
- Only for horizontal or overhead installation for drill hole diameter of 24 mm and bigger.

Description	Ref. No.	Colour	Suitable for drill hole Ø mm	To use in conjunction with	Package content pcs	Weight per pkg. kg
VM-IA 24	85924101	black	24	VM-XL	20	0,04
VM-IA 25	85925101	green	25	VM-XL + VM-XLE16/250	20	0,05
VM-IA 28	85928101	black	28	VM-XL	20	0,08
VM-IA 32	85932101	brown	32	VM-XL + VM-XLE16/250	20	0,10
VM-IA 35	85935101	red	35	VM-XL + VM-XLE16/250	20	0,12
VM-IA 37	85937101	-	37	on demand	20	-

Extension Pipe

- To use with static mixers, two diameters

Description	Ref. No.	Length mm	Diameters mm	To use in conjunction with	Pkg. cont. pcs.	Weight per pkg. kg
VM-XE	28306011	200	10	VM-XL, VM-X, VM-XP	12	0,12
VM-XLE16/250	85959101	250	16	VM-XL	10	0,30

Drill Hole Cleaning

Cleaning Brush RB M6

- With connection thread M6
- Extension for large depths of drill hole
- For drilling machines with keyed chuck
- Separate SDS adaptor with internal thread M6 for SDS plus drills



Description	Ref. No.	Suitable for drill hole Ø mm	Total length of brush mm	Suitable for Threaded stud Reinforcement Bars	Pkg. cont. pcs.	Weight per piece kg
RB 10 M6	33510101	10	130	M8 -	1	0,05
RB 12 M6	33512101	12	140	M10 Ø8	1	0,05
RB 14 M6	33514101	14	180	M12 Ø10	1	0,05
RB 16 M6	33516101	16	200	- Ø12	1	0,05
RB 18 M6	33518101	18	200	M16 Ø14	1	0,05
RB 20 M6	33520101	20	220	- Ø16	1	0,05
RB 24 M6	33524101	24	250	M20 Ø20	1	0,06
RB 28 M6	33528101	28	260	M24 -	1	0,06
RB 32 M6	33532101	32	350	M27 Ø25	1	0,08
RB 35 M6	33535101	35	350	M30 Ø28	1	0,08
RB 37 M6	33537101	37	350	- Ø32	1	0,08
RBL M6	33968101	Brush extension 150mm with connection thread M6			1	0,09
RBL M6 SDS	33350101	SDS Plus adapter with internal thread M6			1	0,06

Blow-out pump VM-AP



→ Drill hole cleaning for Injection System VME according to ETA-09/0350

→ Only for drill holes Ø10mm - Ø18mm up to depth of drill hole depth 240mm

Description	Ref. No.	Suitable for maximum depth of drill hole mm	Pkg. cont. pcs.	Weight per piece kg
VM-AP 360, blow-out pump	33200101	300	1	0,27

Air gun VM-ABP



→ Drill hole cleaning with compressed air for Injection System VME according to ETA-09/0350

→ Only for drill holes Ø20mm - Ø37mm or depth of drill hole deeper than 240mm

Description	Ref. No.	Suitable for maximum depth of drill hole mm	Pkg. cont. pcs.	Weight per piece kg
VM-ABP 250	33100101	240	1	1,00
VM-ABP 500	33106101	480	1	1,30

Dispenser

Dispenser VM-P 385 Profi



→ Professional dispenser with an ideal center of gravity for more comfortable working

→ Automatic pressure release for minimum material overrun

Description	Ref. No.	Suitable for cartridge	Pkg. cont. pcs.	Weight per piece kg
VM-P 385 Profi	28353015	385ml	1	1,20

Dispenser VM-P 585 Profi



→ Professional dispenser with an ideal center of gravity for more comfortable working

→ Combi-tool for many different types of cartridges

→ Automatic pressure release for minimum material overrun

Description	Ref. No.	Suitable for cartridge	Pkg. cont. pcs.	Weight per piece kg
VM-P 585 Profi	28353201	280ml, 300ml, 330ml, 380ml, 385ml, 410ml, 420ml, 585ml	1	1,67

Dispenser VM-P Pneumatic



VM-P 585 Pneumatic

→ Professional air tool with an optimum center of gravity and quick cartridge exchange

→ Automatic pressure release system reduces material overrun to a minimum

→ Single-hand pressure regulation to adjust the piston speed

Description	Ref. No.	Suitable for cartridge	max. working pressure 8bar, 40l/min	Pkg. cont. pcs.	Weight per piece kg
VM-P 585 Pneumatic	28352101	385ml, 585ml		1	3,60
VM-P 1400 Pneumatic	28352201	1400ml		1	6,40



VM-P 1400 Pneumatic



Extract from Permissible Service Conditions of ETA-09/0350.

Approved loads for single anchor without influence of spacing and edge distance.

Total safety factor as per ETAG 001 included (γ_M and γ_P).

Loads and performance data

Injection System VME, threaded stud steel grade 5.8				M8	M10	M12	M16	M20	M24	M27	M30
Range of anchorage depths	$h_{ef,min} - h_{ef,max}$	[mm]		60 - 96	60 - 120	70 - 144	80 - 192	90 - 240	96 - 288	108 - 324	120 - 360
Approved loads, tension for $h_{ef,min} - h_{ef,max}$ cracked concrete											
Range of temperature	24°C/40°C ¹⁾	C20/25	appr. N [kN]	-	-	7,9-16,2	10,2-24,9	10,5-30,8	11,5-40,6	-	-
	43°C/60°C ¹⁾	C20/25	appr. N [kN]	-	-	4,7-9,7	6,4-15,3	6,7-18,0	8,6-25,9	-	-
	43°C/72°C ¹⁾	C20/25	appr. N [kN]	-	-	4,2-8,6	5,6-13,4	5,8-15,4	7,4-22,2	-	-
non-cracked concrete											
Range of temperature	24°C/40°C ¹⁾	C20/25	appr. N [kN]	8,6	9,3-13,8	11,7-20,0	14,3-37,1	14,7-58,1	16,2-83,8	19,3-100,2	22,6-117,3
	43°C/60°C ¹⁾	C20/25	appr. N [kN]	5,7-8,6	7,1-13,8	9,4-19,4	13,6-32,6	14,7-41,0	16,2-55,4	19,3-70,1	22,6-86,6
	43°C/72°C ¹⁾	C20/25	appr. N [kN]	5,1-8,1	6,4-12,7	8,4-17,2	12,0-28,7	13,5-35,9	16,2-51,7	19,3-60,8	22,6-75,0
Approved loads, shear for $h_{ef,min} - h_{ef,max}$ cracked concrete											
Range of temperature	24°C/40°C ¹⁾	C20/25	appr. Q [kN]	-	-	12,0	22,3	29,3-34,9	32,3-50,3	-	-
	43°C/60°C ¹⁾	C20/25	appr. Q [kN]	-	-	11,3-12,0	15,3-22,3	18,8-34,9	24,1-50,3	-	-
	43°C/72°C ¹⁾	C20/25	appr. Q [kN]	-	-	10,1-12,0	13,4-22,3	16,2-34,9	20,7-50,3	-	-
non-cracked concrete											
Range of temperature	24°C/40°C ¹⁾	C20/25	appr. Q [kN]	5,1	8,6	12,0	22,3	34,9	45,2-50,3	54,0-65,7	63,2-80,0
	43°C/60°C ¹⁾	C20/25	appr. Q [kN]	5,1	8,6	12,0	22,3	34,9	45,2-50,3	54,0-65,7	63,2-80,0
	43°C/72°C ¹⁾	C20/25	appr. Q [kN]	5,1	8,6	12,0	22,3	34,9	45,2-50,3	54,0-65,7	63,2-80,0

Injection System VME, threaded stud steel grade 8.8				M8	M10	M12	M16	M20	M24	M27	M30
Range of anchorage depths	$h_{ef,min} - h_{ef,max}$	[mm]		60 - 96	60 - 120	70 - 144	80 - 192	90 - 240	96 - 288	108 - 324	120 - 360
Approved loads, tension for $h_{ef,min} - h_{ef,max}$ cracked concrete											
Range of temperature	24°C/40°C ¹⁾	C20/25	appr. N [kN]	-	-	7,9-16,2	10,2-24,9	10,5-30,8	11,5-40,6	-	-
	43°C/60°C ¹⁾	C20/25	appr. N [kN]	-	-	4,7-9,7	6,4-15,3	6,7-18,0	8,6-25,9	-	-
	43°C/72°C ¹⁾	C20/25	appr. N [kN]	-	-	4,2-8,6	5,6-13,4	5,8-15,4	7,4-22,2	-	-
non-cracked concrete											
Range of temperature	24°C/40°C ¹⁾	C20/25	appr. N [kN]	9,0-13,8	9,3-21,9	11,7-31,9	14,3-53,3	14,7-63,9	16,2-84,0	19,3-100,2	22,6-117,3
	43°C/60°C ¹⁾	C20/25	appr. N [kN]	5,7-9,1	7,1-14,2	9,4-19,4	13,6-32,6	14,7-41,0	16,2-55,4	19,3-70,1	22,6-86,6
	43°C/72°C ¹⁾	C20/25	appr. N [kN]	5,1-8,1	6,4-12,7	8,4-17,2	12-28,7	13,5-35,9	16,2-51,7	19,3-60,8	22,6-75,0
Approved loads, shear for $h_{ef,min} - h_{ef,max}$ cracked concrete											
Range of temperature	24°C/40°C ¹⁾	C20/25	appr. Q [kN]	-	-	18,8-19,4	24,5-36,0	29,3-56,0	32,3-80,6	-	-
	43°C/60°C ¹⁾	C20/25	appr. Q [kN]	-	-	11,3-19,4	15,3-36,0	18,8-50,3	24,1-72,4	-	-
	43°C/72°C ¹⁾	C20/25	appr. Q [kN]	-	-	10,1-19,4	13,4-32,2	16,2-43,1	20,7-62,0	-	-
non-cracked concrete											
Range of temperature	24°C/40°C ¹⁾	C20/25	appr. Q [kN]	8,6	13,1	19,4	34,4-36,0	41,1-56,0	45,2-80,6	54,0-105,1	63,2-128,0
	43°C/60°C ¹⁾	C20/25	appr. Q [kN]	8,6	13,1	19,4	32,6-36,0	41,1-56,0	45,2-80,6	54,0-105,1	63,2-128,0
	43°C/72°C ¹⁾	C20/25	appr. Q [kN]	8,6	13,1	19,4	28,7-36,0	37,7-56,0	45,2-80,6	54,0-105,1	63,2-128,0

Spacing and edge distance

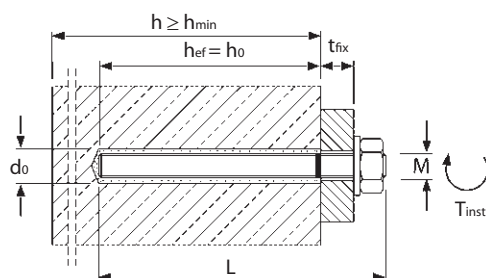
Min. thickness of concrete slab for $h_{ef,min} - h_{ef,max}$	h_{min}	[mm]	100-126	100-150	100-174	116-228	138-288	152-344	172-388	190-430
Minimum spacing	s_{min}	[mm]	40	50	60	80	100	120	135	150
Minimum edge distance	c_{min}	[mm]	40	50	60	80	100	120	135	150

Installation parameters

Drill hole diameter	d_o	[mm]	10	12	14	18	24	28	32	35
Clearance hole in the fixture	d_f	[mm]	9	12	14	18	22	26	30	33
Range of drill hole depth for $h_{ef,min} - h_{ef,max}$	h_o	[mm]	60 - 96	60 - 120	70 - 144	80 - 192	90 - 240	96 - 288	108 - 324	120 - 360
Installation torque	$\leq T_{inst}$	[Nm]	10	20	40	80	120	160	180	200

¹⁾ max long term temperature / max short term temperature
Higher concrete strength may lead to higher approved loads.

For anchor designing an easy to operate CD-ROM is available on request or can be downloaded at www.mkt.de.



Curing time Injection Adhesive VME

→ Cartridge temperature when installing min. +5°C

Temperature (°C) of the base material	maximum working time	minimum curing time	
		dry base material	wet base material
+5°C to +9°C	1:00 h	72 h	144 h
+10°C to +19°C	45 min	36 h	72 h
+20°C to +29°C	30 min	10 h	20 h
+30°C to +39°C	20 min	6 h	12 h
40°C	12 min	4 h	8 h


Extract from Permissible Service Conditions of ETA-09/0350.

Approved loads for single anchor without influence of spacing and edge distance.

 Total safety factor as per ETAG 001 included (γ_M and γ_P).

Loads and performance data

Injection System VME, threaded stud ss A4/316 / SS HCR				M8	M10	M12	M16	M20	M24	M27	M30
Range of anchorage depths	$h_{ef,min} - h_{ef,max}$	[mm]		60 - 96	60 - 120	70 - 144	80 - 192	90 - 240	96 - 288	108 - 324	120 - 360
Approved loads, tension for $h_{ef,min} - h_{ef,max}$ cracked concrete											
Range of temperature	24°C/40°C ¹⁾	C20/25	appr. N [kN]	-	-	7,9-16,2	10,2-24,9	10,5-30,8	11,5-40,6	-	-
	43°C/60°C ¹⁾	C20/25	appr. N [kN]	-	-	4,7-9,7	6,4-15,3	6,7-18,0	8,6-25,9	-	-
	43°C/72°C ¹⁾	C20/25	appr. N [kN]	-	-	4,2-8,6	5,6-13,4	5,8-15,4	7,4-22,2	-	-
non-cracked concrete											
Range of temperature	24°C/40°C ¹⁾	C20/25	appr. N [kN]	9,0-9,9	9,3-15,7	11,7-22,5	14,3-42,0	14,7-63,9	16,2-84,0	19,3-57,4	22,6-70,2
	43°C/60°C ¹⁾	C20/25	appr. N [kN]	5,7-9,1	7,1-14,2	9,4-19,4	13,6-32,6	14,7-41,0	16,2-55,4	19,3-57,4	22,6-70,2
	43°C/72°C ¹⁾	C20/25	appr. N [kN]	5,1-8,1	6,4-12,7	8,4-17,2	12,0-28,7	13,5-35,9	16,2-51,7	19,3-57,4	22,6-70,2
Approved loads, shear for $h_{ef,min} - h_{ef,max}$ cracked concrete											
Range of temperature	24°C/40°C ¹⁾	C20/25	appr. Q [kN]	-	-	13,7	24,5-25,2	29,3-39,4	32,2-56,8	-	-
	43°C/60°C ¹⁾	C20/25	appr. Q [kN]	-	-	11,3-13,7	15,3-25,2	18,8-39,4	24,1-56,8	-	-
	43°C/72°C ¹⁾	C20/25	appr. Q [kN]	-	-	10,1-13,7	13,4-25,2	16,2-39,4	20,7-56,8	-	-
non-cracked concrete											
Range of temperature	24°C/40°C ¹⁾	C20/25	appr. Q [kN]	6,0	9,2	13,7	25,2	39,4	45,2-56,8	34,5	42,0
	43°C/60°C ¹⁾	C20/25	appr. Q [kN]	6,0	9,2	13,7	25,2	39,4	45,2-56,8	34,5	42,0
	43°C/72°C ¹⁾	C20/25	appr. Q [kN]	6,0	9,2	13,7	25,2	37,7-39,4	45,2-56,8	34,5	42,0

Spacing and edge distance

Min. thickness of concrete slab for $h_{ef,min} - h_{ef,max}$	h_{min}	[mm]	100-126	100-150	100-174	116-228	138-288	152-344	172-388	190-430
Minimum spacing	s_{min}	[mm]	40	50	60	80	100	120	135	150
Minimum edge distance	c_{min}	[mm]	40	50	60	80	100	120	135	150

Installation parameters

Drill hole diameter	d_o	[mm]	10	12	14	18	24	28	32	35
Clearance hole in the fixture	d_r	[mm]	9	12	14	18	22	26	30	33
Range of drill hole depth for $h_{ef,min} - h_{ef,max}$	h_o	[mm]	60 - 96	60 - 120	70 - 144	80 - 192	90 - 240	96 - 288	108 - 324	120 - 360
Installation torque	$\leq T_{inst}$	[Nm]	10	20	40	80	120	160	180	200

Injection System VME, reinforcement bars BSt 500 S

				Ø8	Ø10	Ø12	Ø14	Ø16	Ø20	Ø25	Ø28	Ø32
Range of anchorage depths	$h_{ef,min} - h_{ef,max}$	[mm]		60 - 96	60 - 120	70 - 144	75 - 168	80 - 192	90 - 240	100 - 300	112 - 336	128 - 384
Approved loads, tension for $h_{ef,min} - h_{ef,max}$ cracked concrete												
Range of temperature	24°C/40°C ¹⁾	C20/25	appr. N [kN]	-	-	5,8-11,8	5,9-13,2	7,2-17,2	7,7-20,5	9,3-28,0	-	-
	43°C/60°C ¹⁾	C20/25	appr. N [kN]	-	-	3,1-6,5	3,9-8,8	4,0-9,6	4,8-12,8	5,3-16,0	-	-
	43°C/72°C ¹⁾	C20/25	appr. N [kN]	-	-	3,1-6,5	3,3-7,3	4,0-9,6	3,8-10,3	5,3-16,0	-	-
non-cracked concrete												
Range of temperature	24°C/40°C ¹⁾	C20/25	appr. N [kN]	6,6-10,5	8,2-16,5	10,5-21,5	13,0-29,3	14,3-36,4	14,7-46,2	17,2-72,1	20,4-85,5	24,9-111,6
	43°C/60°C ¹⁾	C20/25	appr. N [kN]	3,9-6,2	4,9-9,7	6,8-14,0	7,9-17,6	9,6-23,0	10,6-28,2	14,7-44,1	16,8-50,3	21,9-65,7
	43°C/72°C ¹⁾	C20/25	appr. N [kN]	3,6-5,7	4,5-9,0	5,8-11,8	7,2-16,1	8,8-21,1	9,6-25,6	12,0-36,1	15,1-45,2	19,7-59,1
Approved loads, shear for $h_{ef,min} - h_{ef,max}$ cracked concrete												
Range of temperature	24°C/40°C ¹⁾	C20/25	appr. Q [kN]	-	-	13,8-14,8	14,1-20,0	17,2-26,2	21,5-41,0	26,2-64,3	-	-
	43°C/60°C ¹⁾	C20/25	appr. Q [kN]	-	-	7,5-14,8	9,4-20,0	9,6-23,0	13,5-35,9	15,0-44,9	-	-
	43°C/72°C ¹⁾	C20/25	appr. Q [kN]	-	-	7,5-14,8	7,9-17,6	9,6-23,0	10,8-28,7	15,0-44,9	-	-
non-cracked concrete												
Range of temperature	24°C/40°C ¹⁾	C20/25	appr. Q [kN]	6,7	10,5	14,8	20,0	26,2	41,0	48,1-64,3	57,0-80,5	69,6-105,2
	43°C/60°C ¹⁾	C20/25	appr. Q [kN]	6,7	10,5	14,8	18,8-20,0	23,0-26,2	29,6-41,0	41,1-64,3	46,9-80,5	61,3-105,2
	43°C/72°C ¹⁾	C20/25	appr. Q [kN]	6,7	10,5	13,8-14,8	17,3-20,0	21,1-26,2	26,9-41,0	33,7-64,3	42,2-80,5	55,1-105,2

Spacing and edge distance

Min. thickness of concrete slab for $h_{ef,min} - h_{ef,max}$	h_{min}	[mm]	100-126	100-150	102-176	111-204	120-232	138-288	164-364	182-406	202-458
Minimum spacing	s_{min}	[mm]	40	50	60	70	80	100	125	140	160
Minimum edge distance	c_{min}	[mm]	40	50	60	70	80	100	125	140	160

Installation parameters

Drill hole diameter	d_o	[mm]	12	14	16	18	20	24	32	35	37
Range of drill hole depth for $h_{ef,min} - h_{ef,max}$	h_o	[mm]	60 - 96	60 - 120	70 - 144	75 - 168	80 - 192	90 - 240	100 - 300	112 - 336	128 - 384

¹⁾ max long term temperature / max short term temperature

Higher concrete strength may lead to higher approved loads.

 For anchor designing an easy to operate CD-ROM is available on request or can be downloaded at www.mkt.de.

Post-installed Rebar Connections with Injection System VME



Cartridge VME 385
Side-by-side cartridge
Content: 385ml



Cartridge VME 585
Side-by-side cartridge
Content: 585ml



Cartridge VME 1400
Side-by-side cartridge
Content: 1400ml

Diameter of Rebar: 8 -28 mm
Range of Concrete Quality: C12/15 - C50/60
Material: Reinforcement Bars BSt 500 S

Description

The Injection System VME for post-installed rebar connections has a European Technical Approval (ETA-07/0299). Reinforcement bars from 8 to 28 mm diameter can be fastened in regular concrete from strength class C12/15 to C50/60. As usual the reinforcement can be designed in accordance with EN 1992-1-1:2004 (EC 2). Using the Tension Anchor ZA in sizes M12, M16 and M20 steel structures can be fixed at minimum edge distance. The hole cleaning procedure for the MKT Injection System VME is much easier when hammer drilling or air drilling. Just blow the holes out using compressed air and the specific MKT cleaning tools. The reduced cleaning results in quicker installation saving labor costs. Installer training is provided by MKT and a certificate will be issued by an independent institute, which is recognized by the DIBt.

Applications

Subsequent closing of wall- and ceiling openings, reinforcing existing concrete structures, installation of reinforcement to connect successive structural members, e.g. if reinforcement has been left out or could not be cast in due to the construction sequence, connection of steel structures.



Injection Cartridge VME



- ➔ Very high loads
- ➔ no shrinkage

Description	Ref. No.	Content ml	Content of master box pcs	Weight per master box kg	Weight per piece kg
Cartridge VME 385	28255501	385	12	8,5	0,70
Cartridge VME 585	28255601	585	12	12,09	0,98
Cartridge VME 1400	28255701	1400	5	12,34	2,40
Static mixer VM-XL	28305201	-	10	0,28	0,03

One static mixer VM-XL as well as one screw-on cap comes with each cartridge.



Chemical Anchors

System Case and Accessories for Post-installed Rebar Connections according to Approval ETA -07/0299 and Z-21.8-1872 with Injection System VME:

Description and content:

Compact system case including equipment for every rebar diameter as well as all the tools necessary for the installation of post-installed rebar connections using the Injection System VME in accordance with the European technical approval.



Drilling:

- Drilling aid device
- Flat- / Ring wrench

Accessories for drill hole cleaning:

- Air hose RS 25 and RS 35
- Blow-out nozzle RD Ø12 mm - Ø35 mm
- Cleaning brush RB Ø12 mm - Ø35 mm
- Connection set RS with air valve
- 5 Brush extensions RBL M8, L = 550 mm
- SDS-plus adapter RBL M8-SDS

Accessories for injection:

- Static mixer VM-XL
- Retaining washer VM-IA Ø12 mm - Ø35 mm / 5 pieces each size
- Extension pipe VM-XLE Ø10 mm, Ø16 mm; L = 500 mm
- Frame saw

Other:

- Approval
- Installation sheet and Installation report (available for download at www.mkt.de)
- Filling quantity tables
- Adhesive tape
- Measuring tape
- Thermometer
- Ear protection, Breathing protection, Protective goggles and protective gloves

Description	Ref. No.	Suitable for drill hole Ø mm	Package content pcs.	Weight per piece kg
VME System case	85999101	12 - 35	1	11,8

System Components

- Filling of drill hole
- For drill hole diameter 12 - 35 mm

Description	Ref. No.	Length mm	Rebar-Ø mm	Suitable for drill hole Ø mm	Colour	Package content pcs.	Weight per pck. kg
Extension pipe							
VM-XLE 10/1000	85952101	1000	8 - 12	12 - 16	-	10	0,30
VM-XLE 10/2000	85954101	2000	8 - 12	12 - 16	-	10	0,65
VM-XLE 16/1000	85956101	1000	14 - 28	18 - 35	-	10	1,15
VM-XLE 16/2000	85958101	2000	14 - 28	18 - 35	-	10	3,50
Retaining washer							
VME-IA 12	85912101	-	8	12	white	20	0,04
VME-IA 14	85914101	-	10	14	yellow	20	0,01
VME-IA 16	85916101	-	12	16	blue	20	0,02
VME-IA 18	85918101	-	14	18	black	20	0,01
VME-IA 20	85920101	-	16	20	grey	20	0,02
VME-IA 25	85925101	-	20	25	green	20	0,05
VME-IA 32	85932101	-	25	32	brown	20	0,10
VME-IA 35	85935101	-	28	35	red	20	0,12

Extension pipe VM-XLE can be cut to corresponding drill hole depth.
Extension pipe > 2000 mm on demand.

Cleaning Accessories

- For drill hole cleaning with compressed air
- For drill hole diameter 12 - 35 mm

Description	Ref. No.	Rebar-Ø mm	Suitable for drill hole Ø mm	Package content pcs.	Weight per piece kg
Connection Set RS with air valve	85890101	8 - 28	12 - 35	1	0,40
Air hose RS 25	85802101	8 - 20	12 - 25	1	0,10
Air hose RS 35	85804101	24 - 28	30 - 35	1	0,40
Blow-out nozzle RD 12/14	85852101	8 - 10	12 - 14	1	0,01
Blow-out nozzle RD 16/18	85854101	12 - 14	16 - 18	1	0,02
Blow-out nozzle RD 20/25	85856101	16 - 20	20 - 25	1	0,03
Blow-out nozzle RD 30/35	85858101	24 - 28	30 - 35	1	0,05

Cleaning Brush RB M8

- Drill hole cleaning for diamond core drilling
- With connecting thread M8

Description	Ref. No.	Rebar-Ø mm	Suitable for drill hole Ø mm	Pkg. content pcs.	Weight per piece kg
RB 12 M8	85812101	8	12	1	0,05
RB 14 M8	85814101	10	14	1	0,05
RB 16 M8	85816101	12	16	1	0,05
RB 18 M8	85818101	14	18	1	0,05
RB 20 M8	85820101	16	20	1	0,05
RB 25 M8	85825101	20	25	1	0,06
RB 32 M8	85832101	25	32	1	0,08
RB 35 M8	85835101	28	35	1	0,08
Brush extension RBL M8, L= 550 mm	85871101	8 - 28	12 - 35	1	0,32
SDS-Plus adapter RBL M8 SDS	85881101	-	12 - 35	1	0,07

Please select Brush extension RBL and SDS-Plus adapter according to depth of drill hole.
For drill hole depth > 550 mm, the proper number of Brush extensions must be connected.

Tension Anchor ZA



Thread: M12, M16, M20
Range of Concrete Quality: C12/15 - C50/60
Material: Stainless steel A4/316
On request: Stainless steel HCR

Description

The Tension Anchor ZA consists of a connection thread made of stainless steel A4 or HCR which is welded to a reinforcement bar BSt 500 S.

The Tension Anchor ZA is used with the MKT Injection Adhesive VME and is part of the approvals ETA -07/0299 / Z-21.8-1872. It can be used in cracked and non-cracked concrete and can be designed in accordance with EN 1992-1-1:2004 (EC 2).

Cleaning brushes are required for diamond drilled holes only. If the complete fixture thickness of the Tension Anchor is not required, the reinforcement bar can be cut down to the required length.

Applications

Connection of steel structures to reinforced concrete
 Maximum loads with minimum edge distance possible
 Brackets, canopies, signs, stairs

Tension Anchor ZA



- Stainless steel A4;
High corrosion resistant steel 1.4529 (HCR)
- Approved for cracked and non-cracked concrete



Description	Ref. No.	Drill-hole-Ø mm	max. setting depth mm	Fixture-thickness t _{fix} mm	Anchor-length mm	Weight per piece kg
ZA M12-60/975 A4	85306501	16	900	60	975	0,9
ZA M12-200/1115 A4	85320501	16	900	200	1115	1,0
ZA M16-60/1180 A4	85506501	20	1100	60	1180	1,9
ZA M16-200/1320 A4	85520501	20	1100	200	1320	2,1
ZA M20-60/1485 A4	85606501	25	1400	60	1485	3,7
ZA M20-200/1625 A4	85620501	25	1400	200	1625	4,0

Stainless steel HCR and other lengths on demand.

Cartridge Injection Adhesive VME see page 79
Dispenser see page 76
System Accessories see page 80



Extract from Permissible Service Conditions of ETA-07/0299 and Z-21.8-1872 for Post-installed Rebar Connections and Tension Anchor ZA with Injection System VME

Concrete Strength		C12/15	C16/20	C20/25	C25/30	C30/37	C35/45	C40/50	C45/55	C50/60
		Design value of bond strength f _{bd} [N/mm ²]	Hammer- and pneumatic drilling ¹⁾	1,6	2,0	2,3	2,7	3,0	3,4	3,7
	Diamond core drilling ²⁾	1,6	2,0	2,3	2,7	3,0	3,0	3,4	3,7	3,7

¹⁾ Minimum anchorage lengths l_{0,min} and l_{o,min} according to EN 1992-1-1

²⁾ Minimum anchorage lengths l_{0,min} and l_{o,min} given in the EN 1992-1-1 for anchorages and overlap splices shall be multiplied by the factor 1.5 for diamond core drilling

Installation parameters

Tension Anchor ZA			ZA M12	ZA M16	ZA M20
Drill hole diameter	d ₀	[mm]	16	20	25
Diameter of clearance hole	d _f	[mm]	14	18	22
Effective setting depth	l _v	[mm]	according to static calculation		
Installation torque	≤ T _{inst}	[Nm]	50	100	150
Width across nut	SW	[mm]	19	24	30
max. lap length	l _o	[mm]	800	1000	1300
max. tension load	appr. N	[kN]	35,1	62,4	97,6

Rebar connection

Rebar-Ø	[mm]	8	10	12	14	16	20	24	25	26	28
Drill hole-Ø	d ₀ [mm]	12	14	16	18	20	25	30	32	32	35
Amount of mortar / 100 mm setting depth	[ml]	7,5	9,0	10,6	12,1	13,6	21,2	30,5	37,6	32,8	41,6

Curing Time Injection Adhesive VME

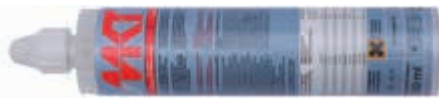
→ Cartridge temperature when installing min. +5°C

Temperature (°C) of the base material	maximum working time	minimum curing time	
		dry base material	wet base material
+5°C to +9°C	1:00 h	72 h	144 h
+10°C to +19°C	45 min	36 h	72 h
+20°C to +29°C	30 min	10 h	20 h
+30°C to +39°C	20 min	6 h	12 h
40°C	12 min	4 h	8 h

Installation



Injection Adhesive VM-K



Cartridge VM-K 300
suitable for silicone guns
Content: 300ml
styrene-free



Cartridge VM-K 345
Side-by-side cartridge
Content: 345ml
styrene-free



Cartridge VM-K 420
Coaxial cartridge
Content: 420ml
styrene-free

Range of loading: 0,3 kN - 39,4 kN

Concrete quality: C20/25 - C50/60

Masonry: Solid brick, Hollow block

Description

The Injection adhesive VM-K is a polyester-resin based injection mortar designed for bonding threaded rods and reinforcing steel in concrete, masonry or natural stone. By using a special perfo sleeve VM-SH (metal or plastic) a secure fastening is also possible in perforated masonry.

The anchoring components from the Chemical Anchor V (see page 61), Injection System VMU (see pages 68-69) or Injection Adhesive VM (see pages 75 & 92) product ranges can be used.

Both components are contained in the cartridge and mixed when dispensed through the static mixer. The Injection adhesive is injected directly into the drilled hole or perfo sleeve with a dispenser gun. The anchoring element is inserted into the filled hole (perfo sleeve) by hand. After the adhesive has cured, the anchoring element can have the load applied.

Advantages

- Styrene free: suitable for interior and exterior use
- suitable for most building materials
- Can be used as a repair mortar
- sealed drill-hole
- Opened cartridges can be re-used with a new static mixer
- Suitable for many anchoring elements e.g. threaded rods, internally threaded sleeves, concrete steel, hooks, screws etc.

Threaded Stud VMU-A

see page 68-69



→ steel, zinc plated

→ Stainless steel A4



Applications

A wide variety of fastenings that do not require federal building office approval.

Injection Cartridge VM-K



→ For universal use in most base materials

→ Three different size cartridges

Description	Ref. No.	Content ml	Content of master box pcs	Weight per master box kg	Weight per piece kg
Cartridge VM-K 300 ¹⁾	28253001	300	12	6,40	0,53
Cartridge VM-K 345	28255201	345	12	7,20	0,58
Cartridge VM-K 420	28256101	420	12	10,1	0,83
Static mixer VM-X (for all cartridges)	28305111	-	12	0,12	0,01
Static mixer VM-XP (only for 420ml cartridge)	28304920	-	10	0,10	0,01
Mixer extension VM-XE (200mm)	28306011	-	12	-	-

One static mixer VM-X as well as one screw-on cap comes with each cartridge.

¹⁾ VM-K 300 is also suitable for use with silicone guns.

Dispenser VM-P 385 Profi

see page 93.



Accessories for Drill Hole Cleaning

see page 93.



Threaded Stud VM-A

see page 75 and 92



→ steel, zinc plated 5,8, steel, zinc plated 8,8

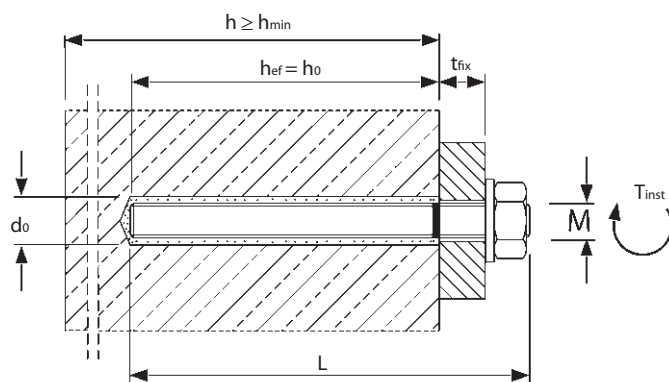
→ Stainless steel A4

→ Threaded studs, of 1 meter length, to be cut to the required length

Recommended loads for single anchor without influence of spacing and edge distance for temperature range -40°C to +80°C¹⁾. Total safety factor as per ETAG 001 included (γ_M and γ_P).

Loads and performance data	Injection Adhesive VM-K with Threaded Studs V-A/VMU-A in concrete			M8	M 10	M 12	M 16	M20
				non-cracked concrete				
Rec. loads, tension (Steel 5.8)	C20/25	rec.N	[kN]	4,8	7,1	9,9	11,1	18,7
Rec. loads, shear (Steel 5.8)	≥ C20/25	rec.V	[kN]	5,1	8,6	12,0	22,3	34,9
Rec. bending moments (Steel 5.8)		rec.M	[Nm]	10,9	21,1	37,1	94,9	185,1
Rec. loads, tension (A4)	C20/25	rec.N	[kN]	4,8	7,1	9,9	11,1	18,7
Rec. loads, shear (A4)	≥ C20/25	rec.V	[kN]	6,0	9,2	13,7	25,2	39,4
Rec. bending moments (A4)		rec.M	[Nm]	11,9	23,8	42,1	106,2	207,9
Spacing and edge distance								
Effective anchorage depth		h_{ef}	[mm]	80	90	110	125	170
Characteristic spacing		$s_{cr,N}$	[mm]	160	180	220	250	340
Characteristic edge distance		$c_{cr,N}$	[mm]	80	90	110	125	170
Minimum thickness of concrete slab		h_{min}	[mm]	110	120	140	161	218
Minimum spacing		s_{min}	[mm]	40	50	60	80	100
Minimum edge distance		c_{min}	[mm]	40	50	60	80	100
Installation parameters								
Drill hole diameter		d_o	[mm]	10	12	14	18	24
Clearance hole in the fixture		d_f	[mm]	9	12	14	18	22
Depth of drill hole		h_o	[mm]	80	90	110	125	170
Installation torque		T_{inst}	[Nm]	10	20	40	60	120
Width across nut		SW	[mm]	13	17	19	24	30
Amount of mortar per drill hole			[ml]	5,2	7,3	10,8	17,1	45,4
Drill holes per cartridge VM-K 300			[Quan.]	50	35	24	15	5
Drill holes per cartridge VM-K 345			[Quan.]	58	41	28	17	6
Drill holes per cartridge VM-K 420			[Quan.]	72	52	35	22	8

¹⁾ max. long term temperature +50°C / max. short term temperature +80°C



Curing Time Injection Adhesive VM-K

→ Cartridge temperature when installing min. +5°C.

Temperature (°C) of base material	working time	curing time
+5°C	25 min	2:00 h
+10°C	15 min	1:20 h
+20°C	6 min	45 min
+30°C	4 min	25 min
+35°C	2 min	20 min

Installation in Concrete



Recommended loads for single anchor without influence of spacing and edge distance for temperature range -40°C to +80°C¹⁾.
Total safety factor as per ETAG 001 included (γ_M and γ_P).

Loads and performance data			Injection System VM-K with threaded stud VM-A / VMU-A		
Steel, zinc plated / Stainless steel A4 in masonry			M8	M10	M12
Recommended bending moments (Steel, zinc plated 5.8)	rec. M	[Nm]	11,0	21,0	37,0
Recommended bending moments (Stainless steel A4)	rec. M	[Nm]	12,0	24,0	42,0
Spacing and edge distance					
Effective anchorage depth with/without perfo sleeve	h_{ef}	[mm]	85/80	85/90	85/110
Spacing (Anchor group) ²⁾³⁾	$a \geq$	[mm]	100	100	100
Minimum spacing ³⁾	min a	[mm]	50	50	50
Spacing (single anchor)	a_z	[mm]	250	250	250
Edge distance	$a_r \geq$	[mm]	250	250	250
Edge distance for special applications ⁴⁾	a_r	[mm]	250	250	250
Minimum thickness of base material (masonry)	h_{min}	[mm]	110	110	125
Installation parameters					
Perfo sleeve (if used)			VM-SH 16x85	16x85	16x85
Diameter of drill hole with perfo sleeve	d_o	[mm]	16	16	16
Dia. of drill hole without perfo sleeve (solid base material)	d_o	[mm]	10	12	14
Clearance hole in the fixture	d_r	[mm]	9	12	14
Depth of drill hole with perfo sleeve	h_o	[mm]	90	90	90
Depth of drill hole without perfo sleeve	h_o	[mm]	85	95	115
Installation torque	T_{inst}	[Nm]	8	8	8
Cleaning brush	d_b	[mm]	RB-H 18	RB-H 18	RB-H 18
Amount of mortar per drill hole with perfo sleeve		[ml]	18,0	18,0	18,0
Amount of mortar per drill hole without perfo sleeve		[ml]	5,2	7,3	10,8
Drill holes per cartridge with perfo sleeve VM-K 345		[Quan.]	16	16	16
Drill holes per cartridge without perfo sleeve VM-K 345		[Quan.]	58	41	28

¹⁾ max. long term temperature +50°C / max. short term temperature +80°C

²⁾ The spacing a may fall below the minimum value for anchor pairs and groups of four, when the loads are reduced. The maximum load per brick must not be exceeded.

³⁾ Hbl, Hbn=200 mm

⁴⁾ Applies to burdened masonry.

Recommended loads in masonry for all load directions	Solid brick ¹⁾		Solid sand-lime ¹⁾			Vertical perforated brick			Sand-lime perforated brick			Hollow block lightw. concrete		Hollow block concrete
	Mz 12	KS 12	HLz 4	HLz 6	HLz 12	KSL 4	KSL 6	KSL 12	Hbl 2	Hbl 4	Hbn 4	Hbl 2	Hbl 4	Hbn 4
[kN]	1,7	1,7	0,3	0,4	0,8	0,3	0,4	0,8	0,3	0,6	0,6	0,3	0,6	0,6

¹⁾ The anchorage in masonry of solid sandlime and solid brick may be made without perfo sleeve.

Maximum load for single brick		$\leq 4 DF^{1)}$	4 to 10 DF ¹⁾	$\geq 10 DF^{1)}$
Unburdened masonry max. F	[kN]	1,0	1,4	2,0
Burdened masonry max. F	[kN]	1,4	1,7	2,5

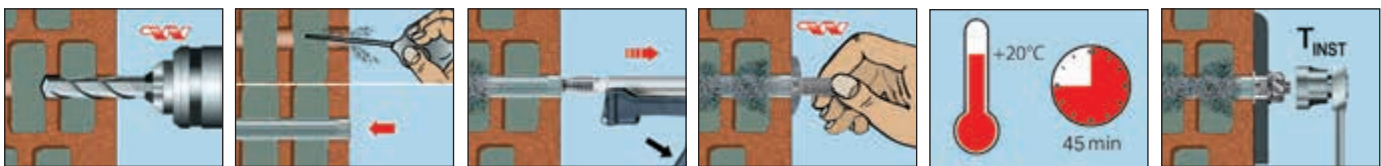
¹⁾ Dimension of brick according to DIN-Standard.

Group of two:
red F = rec. F · ka
 $ka = \left(1 + \frac{\text{red } a}{a}\right) \cdot \frac{1}{2} \leq 1$

Group of four:
red F = rec. F · ka₁ · ka₂
 $ka_{1,2} = \left(1 + \frac{\text{red } a_{1,2}}{a}\right) \cdot \frac{1}{2} \leq 1$

rec. F = recommended load of each anchor
red F = reduced load of each anchor
a = spacing
red a = reduced spacing

Installation



Injection Adhesive VM-PY



Cartridge VM-PY 410
Coaxial cartridge
Content: 410ml

Range of loading: 0,3 kN - 39,4 kN
Concrete quality: C20/25 - C50/60
Masonry: Solid brick, Hollow block



Description

The Injection Adhesive is a polyester-resin based injection mortar for bonding threaded rods and reinforcing steel in concrete, masonry or natural stone. The federal building office approval Z-21.3-1644 shows the use in masonry. The Anchor components and perfo sleeves for masonry can be found in the Injection System VMU range (see page 66-73)

The anchoring components from the Chemical Anchor V (see page 61), Injection System VMU (see pages 68-69) or Injection Adhesive VM (see pages 75 and 92) product ranges can be used.

Both components are contained in the cartridge and mixed when dispensed through the static mixer. The Injection adhesive is injected directly into the drilled hole or perfo sleeve with a dispenser gun. The anchoring element is inserted into the filled hole (perfo sleeve) by hand. After the adhesive has cured, the anchoring element can have the load applied.

Advantages

- Federal building office approval for solid and perforated building blocks
- suitable for most construction base materials
- Can be used as a repair mortar
- sealed drill-hole
- Opened cartridges can be re-used with a new static mixer
- Suitable for many anchoring elements e.g. threaded rods, female-thread sleeves, concrete steel, hooks, screws etc.

Applications

A wide variety of fastenings that do not require federal building office approval.

Threaded Stud VMU-A

see page 68-69



- steel, zinc plated
- Stainless steel A4



Injection Cartridge VM-PY



- For universal use in most base materials
- Approved for solid and perforated brickwork

Description	Ref. No.	Content ml	Content of master box pcs	Weight per master box kg	Weight per piece kg
Cartridge VM-PY 410	28256002	410	12	9,95	0,83
Static mixer VM-X	28305111	-	12	0,12	0,01
Mixer extension VM-XE (200mm)	28306011	-	12	-	-

One static mixer comes with each cartridge.

Dispenser VM-P 385 Profi

see page 93.



Accessories for Drill Hole Cleaning

see page 93.



Threaded Stud VM-A

see page 75 and 92

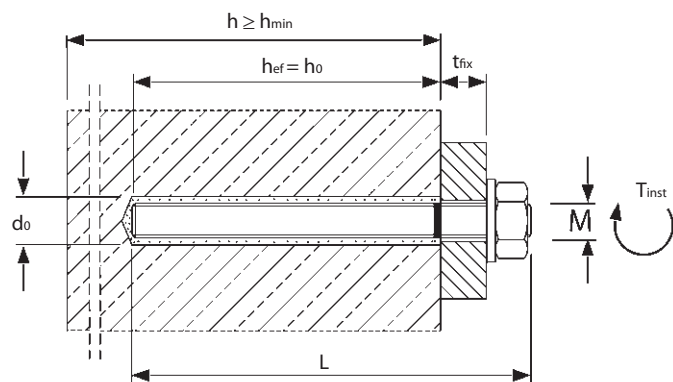


- steel, zinc plated 5.8, steel, zinc plated 8.8
- Stainless steel A4
- Threaded studs, of 1 meter length, to be cut to the required length

Recommended loads for single anchor without influence of spacing and edge distance for temperature range -40°C to +80°C¹⁾.
Total safety factor as per ETAG included (γ_m and γ_p).

Loads and performance data	Injection Adhesive VM-PY with Threaded Studs V-A/VM-A/VMU-A in concrete			M8	M 10	M 12	M 16	M20
	non-cracked concrete							
Rec. loads, tension (Steel 5.8)	≥ C20/25	rec. N	[kN]	4,4	6,7	9,5	10,7	18,3
Rec. loads, shear (Steel 5.8)	≥ C20/25	rec. V	[kN]	5,1	8,6	12,0	22,3	34,9
Rec. bending moments (Steel 5.8)		rec. M	[Nm]	10,9	21,1	37,1	94,9	185,1
Rec. loads, tension (A4)	≥ C20/25	rec. N	[kN]	4,4	6,7	9,5	10,7	18,3
Rec. loads, shear (A4)	≥ C20/25	rec. V	[kN]	6,0	9,2	13,7	25,2	39,4
Rec. bending moments (A4)		rec. M	[Nm]	11,9	23,8	42,1	106,2	207,9
Spacing and edge distance								
Effective anchorage depth		h_{ef}	[mm]	80	90	110	125	170
Characteristic spacing		$s_{cr,N}$	[mm]	160	180	220	250	340
Characteristic edge distance		$c_{cr,N}$	[mm]	80	90	110	125	170
Minimum thickness of concrete slab		h_{min}	[mm]	110	120	140	161	218
Minimum spacing		s_{min}	[mm]	40	50	60	80	100
Minimum edge distance		c_{min}	[mm]	40	50	60	80	100
Installation parameters								
Drill hole diameter		d_o	[mm]	10	12	14	18	24
Clearance hole in the fixture		d_f	[mm]	9	12	14	18	22
Depth of drill hole		h_o	[mm]	80	90	110	125	170
Installation torque		T_{inst}	[Nm]	10	20	40	60	120
Width across nut		SW	[mm]	13	17	19	24	30
Amount of mortar per drill hole			[ml]	5,2	7,3	10,8	17,1	45,4
Drill holes per cartridge VM-PY 410			[Quan.]	71	50	34	21	8

¹⁾ max. long term temperature +50°C / max. short term temperature +80°C



Curing Time Injection Adhesive VM-PY

→ Cartridge temperature when installing min. +5°C.

Temperature (°C) of base material	working time	curing time
+5°C	25 min	2:00 h
+10°C	15 min	1:20 h
+20°C	6 min	45 min
+30°C	4 min	25 min
+35°C	2 min	20 min

Installation in Concrete





Extract from Permissible Service Conditions of Z-21.3-1814

Approved loads for single anchor without influence of spacing and edge distance for temperature range -40°C to +80°C⁶⁾.
Total safety factor as per ETAG included (γ_M and γ_F).

Loads and performance data	Injection adhesive VM-PY with threaded stud VMU-A/AH/IG/IGH steel, zinc plated / stainless steel A4 / HCR in masonry		VMU-A		VMU-AH		VMU-IG/VMU-IGH	
			M 8	M 10	M 12	M 12	M 6	M 8
Approved bending moments (Steel, zinc plated 5.8)	appr. M	[Nm]	11,0	21,0	37,0	37,0	4,4	11,0
Approved bending moments (Stainless steel A4)	appr. M	[Nm]	12,0	24,0	42,0	42,0	4,9	12,0
Appr. bending moments (Stainless steel HCR 1.4529)	appr. M	[Nm]	9,4	19,0	33,0	33,0	4,9	9,4
Spacing and edge distance								
Effective anchorage depth	h_{ef}	[mm]	80	90	93	93	93	93
Spacing (Anchor group) ²⁾	$a \geq$	[mm]			100 (200) ²⁾			
Minimum spacing	min a	[mm]			50 ³⁾			
Spacing (single anchor)	a_z	[mm]			250			
Edge distance	$a_r \geq$	[mm]			200 (250) ⁴⁾			
Edge distance for special applications	a_r	[mm]			50 (60) ⁴⁾			
Minimum thickness of base material (masonry)	h_{min}	[mm]			110			
Installation parameters								
Thread length of screw/threaded stud	min s	[mm]	-	-	-	-	8	8
	max s	[mm]	-	-	-	-	20	20
Diameter of drill hole with perfo sleeve	d_o	[mm]	14	16	-	16	16	16
Dia. of drill hole without perfo sleeve (solid base material)	d_o	[mm]	10	12	14	-	12	14
Clearance hole in the fixture	d_f	[mm]	9	12	14	14	7	9
Depth of drill hole with perfo sleeve	h_o	[mm]	105	105	-	105	105	105
Depth of drill hole without perfo sleeve (solid base material)	h_o	[mm]	85	95	98	-	98	98
Installation torque	T_{inst}	[Nm]	8 ⁵⁾	8 ⁵⁾	8 ⁵⁾	8 ⁵⁾	8 ⁵⁾	8 ⁵⁾
Diameter cleaning brush RB-H 18	d_B	[mm]	18	18	18	18	18	18
Amount of mortar per drill hole with perfo sleeve	[ml]		15,0	21,0	-	21,0	21,0	21,0
Amount of mortar per drill hole without perfo sleeve	[ml]		5,2	7,3	9,8	-	7,3	9,8
Drill holes per cartridge with perfo sleeve VM-PY 410	[Quan.]		24	17	-	17	17	17
Drill holes per cartridge without perfo sleeve VM-PY 410	[Quan.]		71	50	37	-	50	37

¹⁾ For reduced spacing, please view approval Z-21.3-1814.

²⁾ Value in brackets for Hbl (Hollow block concrete, according to DIN 18151) and Hbn (Hollow block concrete, DIN 18153).

³⁾ min a not valid for Hbl and Hbn brickwork.

⁴⁾ Value in brackets valid for solid brick.

⁵⁾ 2 Nm if anchor plate is not seated solidly on surface of base material.

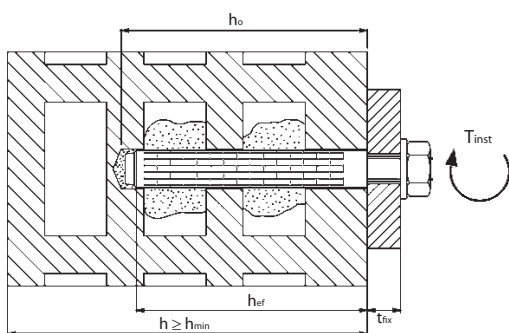
⁶⁾ max. long term temperature +50°C / max. short term temperature +80°C.

Recommended loads in masonry for all load directions	[kN]	Solid brick		Vertical perforated brick			Sand-lime perforated brick			Hollow block lightw. concrete		Hollow block concrete
		Mz 12	KS 12	HLz 4	HLz 6	HLz 12	KSL 4	KSL 6	KSL 12	Hbl 2	Hbl 4	Hbn 4
Drilling with rotation only;	[kN]	1,7	1,7	0,6	0,8	1,0	0,6 ¹⁾	0,8 ¹⁾	1,4 ¹⁾	0,5	0,8	0,8
Drilling with hammer action	[kN]	1,7	1,7	0,3	0,4	0,8	0,4	0,6	0,8	0,3	0,6	0,6

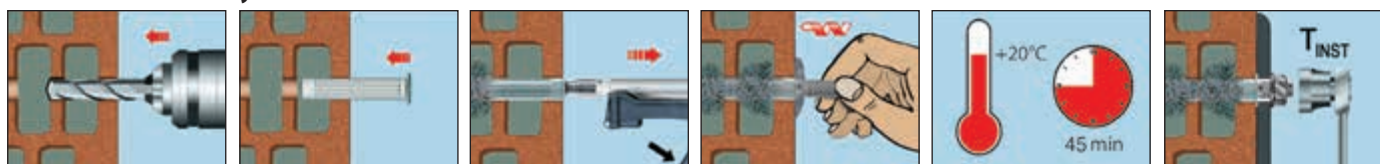
¹⁾ Outer web ≥ 30 mm

Maximum load for single brick		$\leq 3 DF^{1)}$	4 to 10 DF ¹⁾	$\geq 10 DF^{1)}$
Unburdened masonry max. F	[kN]	1,0	1,4	2,0
Burdened masonry max. F	[kN]	1,4	1,7	2,5

¹⁾ Dimension of brick according to DIN-Standard.



Installation in Masonry



Injection Adhesive VM-Polar



Cartridge VM-Polar
Side-by-side cartridge
Content: 345ml

Range of loading: 0,3 kN - 128 kN
Concrete quality: C20/25 - C50/60
Brickwork : Solid and perforated brick

Description

The Injection adhesive VM-Polar is a vinylester-resin based injection mortar designed for bonding threaded rods and reinforcing steel in concrete, masonry or natural stone. It is especially suitable for use in very low temperatures. The Cartridge and base material temperature can be as low as -20°C.

By using a special perfo sleeve VM-SH (metal or plastic) a safe fastening is also possible in perforated masonry. The anchoring components from the Chemical Anchor V (see page 61), Injection System VMU (see pages 68-69) or Injection Adhesive VM (see pages 75 & 92) product ranges can be used.

Both components are contained in the cartridge and mixed when dispensed through the static mixer. The Injection adhesive is injected directly into the drilled hole or perfo sleeve with a dispenser gun. The anchoring element is inserted into the filled hole (perfo sleeve) by hand. After the adhesive has cured, the anchoring element can have the load applied.

Advantages

- Can be used for installing in temperatures as low as -20°C
- At time of use the cartridge temperature can be as low as 20°C
- Styrene free: suitable for interior and exterior use
- suitable for most building materials
- Can be used as a repair mortar
- sealed drill-hole
- Opened cartridges can be re-used with a new static-mixer
- Suitable for many anchoring elements e.g. threaded rods, female-thread sleeves, concrete steel, hooks, screws etc.

Threaded Stud VMU-A

see page 68-69



- steel, zinc plated
- Stainless steel A4

Threaded Stud VM-A

see page 75 und 92



- steel, zinc plated 5,8, steel, zinc plated 8,8
- Stainless steel A4
- Threaded studs, of 1 meter length, to be cut to the required length



Applications

Installations in low temperatures that need no federal building office approval.

Injection Adhesive VM-Polar



- For universal use in most base materials
- Cartridge temperature when installing min. -20°C

Description	Ref. No.	Content ml	Content of master box pcs	Weight per master box kg	Weight per piece kg
Cartridge VM-Polar 345	28255326	345	12	7,20	0,58
Static mixer VM-X	28305111	-	12	0,12	0,01
Mixer extension VM-XE (200mm)	28306011	-	12	-	-

One static mixer comes with each cartridge.

Dispenser VM-P

see page 93.



Accessories for Drill Hole Cleaning

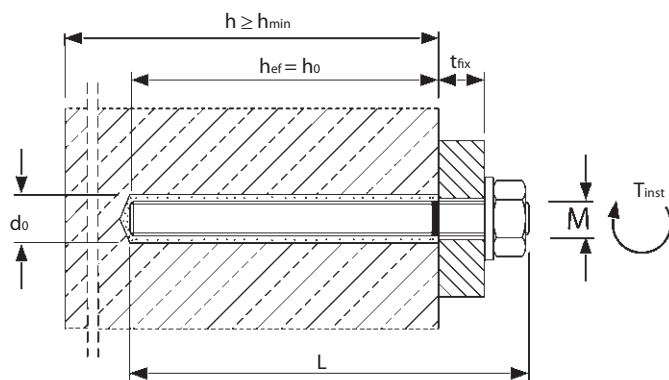
see page 93.



Recommended loads for single anchor without influence of spacing and edge distance for temperature range -40°C to +80°C¹⁾. Total safety factor as per ETAG 001 included (γ_M and γ_P).

Loads and performance data			Injection Adhesive VM-Polar with threaded stud V-A/VMU-A in concrete								
			M8	M10	M12	M16	M20	M24	M27	M30	
non-cracked concrete											
Rec. loads, tension (Steel 5.8)	C20/25	rec. N	[kN]	6,3	9,9	13,8	19,8	38,2	43,7	52,4	65,5
Rec. loads, shear (Steel 5.8)	≥ C20/25	rec. V	[kN]	5,1	8,6	12,0	22,3	34,9	50,3	65,7	80,0
Rec. bending moments (Steel 5.8)		rec. M	[Nm]	10,9	21,1	37,1	94,3	185,7	320,6	476,0	642,3
Rec. loads, tension (8.8)	C20/25	rec. N	[kN]	6,3	9,9	13,8	19,8	38,2	43,7	52,4	65,5
Rec. loads, shear (8.8)	≥ C20/25	rec. V	[kN]	8,6	13,1	19,4	36,0	56,0	80,6	104,8	128,0
Rec. bending moments (8.8)		rec. M	[Nm]	17,1	34,3	60,0	152,0	296,6	513,1	761,7	1028,0
Rec. loads, tension (A4)	C20/25	rec. N	[kN]	6,3	9,9	13,8	19,8	38,2	43,7	52,4	65,5
Rec. loads, shear (A4)	≥ C20/25	rec. V	[kN]	6,0	9,2	13,7	25,2	39,4	56,8	34,5	42,0
Rec. bending moments (A4)		rec. M	[Nm]	11,9	23,8	42,1	106,7	207,9	359,0	249,7	337,0
Spacing and edge distance											
Effective anchorage depth	h_{ef}	[mm]		80	90	110	125	170	210	250	280
Characteristic spacing	$s_{cr,N}$	[mm]		160	180	220	250	340	420	500	560
Characteristic edge distance	$c_{cr,N}$	[mm]		80	90	110	125	170	210	250	280
Minimum thickness of concrete slab	h_{min}	[mm]		110	120	140	161	218	266	314	350
Minimum spacing	s_{min}	[mm]		40	50	60	80	100	120	135	150
Minimum edge distance	c_{min}	[mm]		40	50	60	80	100	120	135	150
Installation parameters											
Drill hole diameter	d_o	[mm]		10	12	14	18	24	28	32	35
Clearance hole in the fixture	d_f	[mm]		9	12	14	18	22	26	30	33
Depth of drill hole	h_o	[mm]		80	90	110	125	170	210	250	280
Installation torque	T_{inst}	[Nm]		10	20	40	60	120	150	200	250
Width across nut	SW	[mm]		13	17	19	24	30	36	41	46
Amount of mortar per drill hole		[ml]		5,2	7,3	10,8	17,1	45,4	67,8	105,0	136,4
Drill holes per cartridge VM-Polar 345		[Quan.]		58	41	28	17	6	4	2	2

¹⁾ max. long term temperature +50°C / max. short term temperature +80°C



Curing Time Injection Adhesive VM-Polar

→ Cartridge temperature when installing min. -20°C

Temperature (°C) of base material	working time	curing time	
		dry base material	wet base material
-20°C	90 min	24 h	48 h
-15°C	75 min	16 h	32 h
-10°C	60 min	10 h	20 h
-5°C	50 min	5 h	10 h
0°C	25 min	150 min	300 min
+5°C	10 min	80 min	160 min
+10°C	6 min	60 min	120 min
+15°C	3 min	45 min	90 min
+20°C	1,5 min	35 min	70 min

Installation



Recommended loads for single anchor without influence of spacing and edge distance for temperature range -40°C to +80°C¹⁾.
Total safety factor as per ETAG 001 included (γ_M and γ_P).

Loads and performance data		Injection Adhesive VM-Polar with threaded stud VM-A / VMU-A, Steel, zinc plated / Stainless steel A4 in masonry			
		M8	M10	M12	
Recommended bending moments (Steel, zinc plated 5.8)	rec. M [Nm]	11,0	21,0	37,0	
Recommended bending moments (Stainless steel A4)	rec. M [Nm]	12,0	24,0	42,0	
Spacing and edge distance					
Effective anchorage depth with/without perfo sleeve	h_{ef} [mm]	85/80	85/90	85/110	
Spacing (Anchor group) ²⁾³⁾	$a \geq$ [mm]	100	100	100	
Minimum spacing ³⁾	min a [mm]	50	50	50	
Spacing (single anchor)	a_z [mm]	250	250	250	
Edge distance	$a_r \geq$ [mm]	250	250	250	
Edge distance for special applications ⁴⁾	a_r [mm]	250	250	250	
Minimum thickness of base material (masonry)	h_{min} [mm]	110	110	125	
Installation parameters					
Perfo sleeve (if used)		VM-SH 16x85	16x85	16x85	
Diameter of drill hole with perfo sleeve	d_o [mm]	16	16	16	
Dia. of drill hole without perfo sleeve (solid base material)	d_o [mm]	10	12	14	
Clearance hole in the fixture	d_f [mm]	9	12	14	
Depth of drill hole with perfo sleeve	h_o [mm]	90	90	90	
Depth of drill hole without perfo sleeve	h_o [mm]	85	95	115	
Installation torque	T_{inst} [Nm]	8	8	8	
Cleaning brush	d_b [mm]	RB-H 18	RB-H 18	RB-H 18	
Amount of mortar per drill hole with perfo sleeve	[ml]	18,0	18,0	18,0	
Amount of mortar per drill hole without perfo sleeve	[ml]	5,2	7,3	10,8	
Drill holes per cartridge with perfo sleeve VM-Polar	[Quan.]	16	16	16	
Drill holes per cartridge without perfo sleeve VM-Polar	[Quan.]	58	41	28	

¹⁾ max. long term temperature +50°C / max. short term temperature +80°C

³⁾ Hbl, Hbn=200 mm

²⁾ The spacing a may fall below the minimum value for anchor pairs and groups of four, when the loads are reduced. The maximum load per brick must not be exceeded.

⁴⁾ Applies to burdened masonry.

Recommended loads in masonry for all load directions	Solid brick ¹⁾	Solid sand-lime ¹⁾	Vertical perforated brick			Sand-lime perforated brick			Hollow block lightw. concrete		Hollow block concrete
	Mz 12 [kN]	KS 12 [kN]	HLz 4	HLz 6	HLz 12	KSL 4	KSL 6	KSL 12	Hbl 2	Hbl 4	Hbn 4
	1,7	1,7	0,3	0,4	0,8	0,3	0,4	0,8	0,3	0,6	0,6

¹⁾ The anchorage in masonry of solid sandlime and solid brick may be made without perfo sleeve.

Maximum load for single brick		$\leq 4 DF^1)$	4 to 10 DF ¹⁾	$\geq 10 DF^1)$
Unburdened masonry max. F	[kN]	1,0	1,4	2,0
Burdened masonry max. F	[kN]	1,4	1,7	2,5

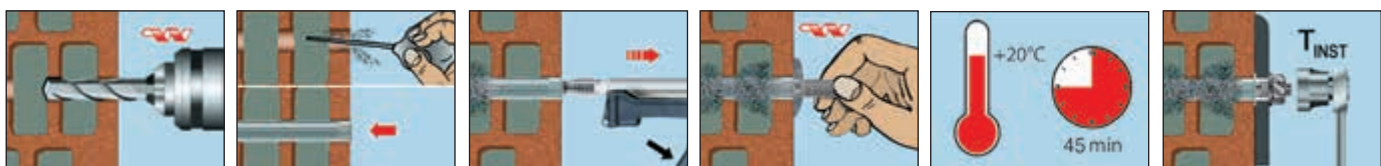
¹⁾ Dimension of brick according to DIN-Standard.

Group of two:
red F = rec. F · ka
 $ka = \left(1 + \frac{\text{red } a}{a}\right) \cdot \frac{1}{2} \leq 1$

Group of four:
red F = rec. F · ka
 $ka_{1,2} = \left(1 + \frac{\text{red } a_{1,2}}{a}\right) \cdot \frac{1}{2} \leq 1$

rec. F = recommended load of each anchor
red F = reduced load of each anchor
a = spacing
red a = reduced spacing

Installation



Injection Adhesive VM

Combi-Box

→ The multi purpose box

→ Combi-Box may be combined into sets

Description	Ref. No.	Contents	Quantity	Weight per
			pcs.	Box kg
Combi-Box VM 1 styrene free	28999101	Cartridge VM-K 345	2	4,06
		Dispenser VM-P 345	1	
		Blow-out bulb VM-AP 270	1	
		Static mixer VM-X	4	
		Cleaning Brush RB-H 12 nylon	1	
Combi-Box VM 2 styrene free	28999090	Cartridge VMU 345	5	6,24
		Dispenser VM-P 345	1	
		Blow-out bulb VM-AP 270	1	
		Static mixer VM-X	10	
Combi-Box VM-K 345 styrene free	28999111	Cartridge VM-K 345	25	20,02
		Static mixer VM-X	50	

Dimensions Combi-Box

Description	Height mm	Width mm	Depth mm
Combi-Box VM 1	105	395	295
Combi-Box VM 2	158	395	295
Combi-Box VM-K 345	315	395	295



Stock-Box

→ In stackable multi-purpose container

→ Stock-Box, the container for various items

Description	Ref. No.	Contents	Quantity	Weight per
			pcs.	Box kg
Stock-Box VM-K 345	28999160	Cartridge VM-K 345	20	15,5
		Static mixer VM-X	40	
Stock-Box VM-K 300	28999166	Cartridge VM-K 300	20	12,5
		Static mixer VM-X	40	
Stock-Box VM-Polar 345	28999157	Cartridge VM-Polar 345	20	15,5
		Static mixer VM-X	40	

Dimensions Stock-Box

Description	Height mm	Width mm	Depth mm
Stock-Box	220	400	300

Accessories for Installation in hollow base materials

Threaded Stud VM-A



→ Steel, zinc plated, grade 5.8

→ Installation in brickwork

Description	Ref. No.	Suitable for perfo sleeve	Fixture thickness t _{fix} mm	Package content pcs.	Weight per package kg
VM-A 6 x 70	28051001	VM-SH 12	15	10	0,18
VM-A 8 x 100	28052001	VM-SH 12 / 16	45 / 5	10	0,40
VM-A 10 x 110	28053001	VM-SH 16	15	10	0,71
VM-A 10 x 135	28053051	VM-SH 16	40	10	0,82
VM-A 12 x 115	28054001	VM-SH 20 / 22	20	10	1,07

Int. Threaded Sleeve VM-IG



→ Steel, zinc plated

→ Installation in hollow base materials

Description	Ref. No.	Suitable for perfo sleeve	Internal thread	Outer-ø mm	Package content pcs.	Weight per package kg
VM-IG M 6	28101001	VM-SH 12 / 16	M 6	8	10	0,11
VM-IG M 8	28102001	VM-SH 16 / 22	M 8	12	10	0,38
VM-IG M 10	28103001	VM-SH 20 / 22	M 10	14	10	0,45
VM-IG M 12	28104001	VM-SH 22	M 12	16	10	0,52

Perfo Sleeve VM-SH



→ Plastic

→ Installation in hollow base materials

Description	Ref. No.	Drill hole Ø x depth mm	Suitable for		Package content pcs.	Weight per package kg
			Threaded Stud	Threaded Sleeve		
VM-SH 12 x 50	28151001	13 x 55	M 6 - M 8	VM-IG M6	10	0,01
VM-SH 12 x 85	28151201	13 x 90	M 6 - M 8	VM-IG M6	10	0,02
VM-SH 16 x 85	28152001	16 x 90	M 8 - M 10	VM-IG M8	10	0,03
VM-SH 16 x 130	28153001	16 x 135	M 8 - M 10	-	10	0,04
VM-SH 20 x 85	28154001	22 x 90	M12	VM-IG M10	10	0,04

Perfo Sleeve VM-SH



→ Metal, to be cut to required length

→ Installation in hollow base materials

Description	Ref. No.	Drill hole Ø mm	Suitable for		Package content pcs.	Weight per package kg
			Threaded Studs	Threaded Sleeve		
VM-SH 12 x 1000	28403001	12	M6-M8	VM-IG M6	50	2,88
VM-SH 16 x 1000	28404001	16	M10	VM-IG M6-M8	50	3,38
VM-SH 22 x 1000	28405001	22	M12-M16	VM-IG M8-M12	25	2,70

Accessories for Installation in concrete

Threaded Stud V-A



→ Steel, zinc plated, grade 5.8

→ Installation in non-cracked concrete

Description	Ref. No.	Drill hole depth mm	Thread Ø x length mm	Package content pcs.	Weight per package kg
V-A 8-20/110	21101101	80	20	10	0,43
V-A 10-30/130	21203101	90	30	10	0,81
V-A 12-35/160	21306101	110	35	10	1,37
V-A 16-45/190	21510101	125	45	10	2,96
V-A 20-60/260	21617101	170	60	10	6,39
V-A 24-55/300	21721101	210	55	5	5,54

Other lengths see page 61.

Int. Threaded Sleeve V-IG



→ Steel, zinc plated grade 5.8

→ Fixture easy to remove; sealed drill hole

Description	Ref. No.	Drill hole Ø x depth mm	Thread Ø x length mm	Package content pcs.	Weight per package kg
V-IG M 8	24105101	14x90	M8x25	10	0,50
V-IG M 10	24205101	16x90	M10x30	10	0,65
V-IG M 12	24305101	18x100	M12x35	10	1,00
V-IG M 16	24505101	25x120	M16x40	10	1,65

Int. Threaded Sleeve V-IG A4



→ Stainless steel A4/316

→ Fixture easy to remove; sealed drill hole

Description	Ref. No.	Drill hole Ø x depth mm	Thread Ø x length mm	Package content pcs.	Weight per package kg
V-IG M 10 A4	24205501	16x90	M10x30	10	0,65
V-IG M 12 A4	24305501	18x100	M12x35	10	1,00
V-IG M 16 A4	24505501	25x120	M16x40	10	1,65

Centering Sleeve VM-ZR



→ Plastic

→ Avoid sliding of Threaded Stud in drill hole.

Description	Ref. No.	For Threaded Studs	Package content pcs.
VM-ZR M 8	28201001	M 8	10
VM-ZR M 10	28202001	M 10	10
VM-ZR M 12	28203001	M 12	10
VM-ZR M 16	28204001	M 16	10
VM-ZR M 20	28205001	M 20	10

Cleaning Brush RB M6



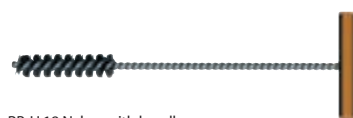
RB M6, with connection thread M6



RBL M6, with internal and external thread M6



RBL M6 SDS, with internal thread M6



RB-H 18 Nylon, with handle

Blow-out pump VM-AP



Air gun VM-ABP



Dispenser VM-P Profi



Dispenser VM-P Standard



Dispenser VM-P Pneumatic

→ With connection thread M6 – extension for large depths of drill hole and/or for through-setting installation

→ For drilling machines with keyed chuck or with SDS adaptor for SDS plus drills

Description	Ref. No.	Suitable for drill hole Ø mm	Total length of brush mm	Base material	Suitable for Threaded stud with VM-K, VM-PY, VM-Polar	Pkg. cont. pcs	Weight per piece kg
RB 10 M6	33510101	10	130	concrete	M8	1	0,05
RB 12 M6	33512101	12	140	concrete	M10	1	0,05
RB 14 M6	33514101	14	180	concrete	M12	1	0,05
RB 18 M6	33518101	18	200	concrete	M16	1	0,05
RB 24 M6	33524101	24	250	concrete	M20	1	0,06
RB 28 M6	33528101	28	260	concrete	M24	1	0,06
RB 32 M6	33532101	32	350	concrete	M27	1	0,06
RB 35 M6	33535101	35	350	concrete	M30	1	0,08
RBL M6	33968101	Brush extension 150mm with connection thread M6				1	0,09
RBL M6 SDS	33350101	SDS Plus adapter with internal thread M6				1	0,06

→ Drill hole cleaning in solid and hollow base material

Description	Ref. No.	Suitable for drill hole Ø mm	Base material	Pkg. cont. pcs	Weight per piece kg
RB-H 12/250	29914501	8-12	brickwork	1	0,04
RB-H 18/250	29918501	10-18	brickwork	1	0,04
RB-H 18/400	33618101	10-18	brickwork	1	0,05
RB-H 28/280	29928501	20-28	brickwork	1	0,05

→ Drill hole cleaning for VMU-A / VMU-AH M8-M16 and VMU-IG / VMU-IGH M6-M8

Description	Ref. No.	Length mm	max. depth of drill hole mm	Pkg. cont. pcs	Weight per piece kg
Blow-out pump VM-AP 270	29990002	270	200	1	0,22
Blow-out pump VM-AP 360	33200101	360	300	1	0,27

→ Drill hole cleaning with compressed air for VMU-A M20-M30

Desc	Ref. No.	Suitable for maximum depth of drill hole mm	Suitable for drill hole Ø mm	Pkg. cont. pcs	Weight per piece kg
VM-ABP 250	33100101	240	≥ 20	1	1,00
VM-ABP 500	33106101	480	≥ 20	1	1,30

→ Professional dispenser with an ideal center of gravity for more comfortable working

→ Automatic pressure release for minimum material overrun

Description	Ref. No.	Suitable for cartridge	Pkg. cont. pcs.	Weight per piece kg
VM-P 345 Profi	28350511	150ml, 280ml, 300ml, 345ml also suitable for silicone cartridges	1	1,00
VM-P 380 Profi	28351001	380ml, 410ml, 420ml	1	1,10

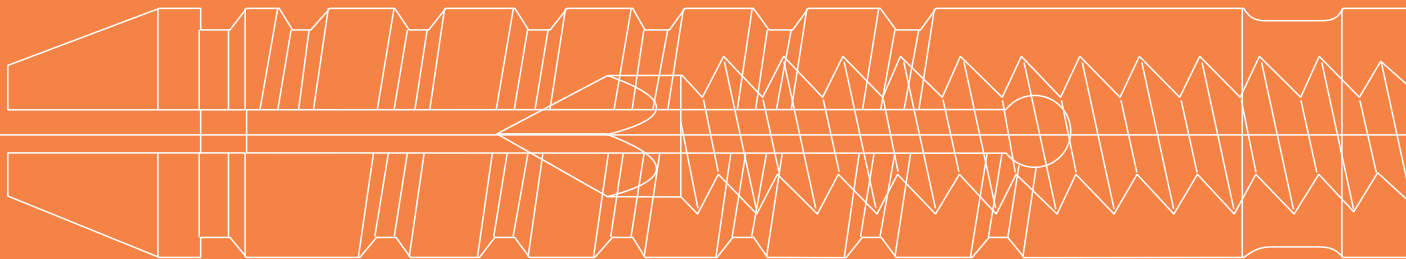
→ For occasional use, metal version

→ Piston rod with adjusting screw

Description	Ref. No.	Suitable for cartridge	Pkg. cont. pcs.	Weight per piece kg
VM-P 345 Standard	28350505	150ml, 280ml, 300ml, 345ml also suitable for silicone cartridges	1	1,00
VM-P 380 Standard	28353005	380ml, 410ml, 420ml	1	1,15

see page 70.

Light Duty Anchors



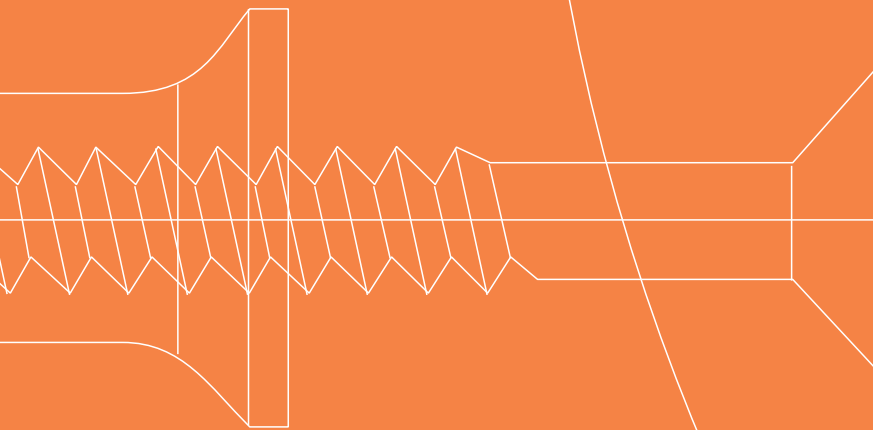


Mechanical Heavy Duty Anchors

Chemical Anchors

Light Duty Anchors

Service



Nail Plug ND



Nail Plug ND-S

Nail Plug ND-Z

Description

The Nail Plug ND is a time saving hammer-in nylon plug with pre-assembled zinc plated nail-screw, suitable for most types of base materials. It is weather-proof and temperature-resistant from -40°C to 80°C. The Nailplug can be unscrewed for Readjustment or removing.

Applications

Frames, skirting boards, wood battens, pipe clips, angles, brackets

Range of loading: 0,04 kN - 0,36 kN



Nail Plug ND

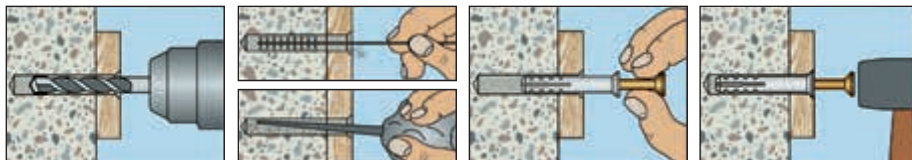
- High grade polyamide with zinc plated nailscrew
- With countersunk head and cylindrical head

Description	Ref. No. Typ ND-S counter sunk	Ref. No. Typ ND-Z cheese head	Anchor-length mm	Fixture thickness t_{fix} mm	Package content pcs. ND-S/ND-Z	Packages per master box		Weight per master box kg ND-S/ND-Z
						ND-S/ND-Z	ND-S/ND-Z	
ND 5/30	70105101	70105181	30	5	100 / 100	36 / 36	9,9 / 9,9	
ND 5/40	70115101	-	40	15	100 / -	27 / -	9,6 / -	
ND 6/35	70205101	70205181	35	5	100 / 100	16 / 16	6,4 / 6,4	
ND 6/50	70220101	70220181	50	20	100 / 100	16 / 16	8,3 / 8,3	
ND 6/60	70230101	-	60	30	100 / -	16 / -	8,3 / -	
ND 6/75	70245101	-	75	45	100 / -	16 / -	11,8 / -	
ND 8/60	70305101	70305181	60	20	100 / 100	8 / 9	8,7 / 9,8	
ND 8/80	70315101	70315181	80	40	100 / 100	8 / 8	10,6 / 10,6	
ND 8/100	70325101	-	100	60	100 / -	8 / -	12,9 / -	
ND 8/120	70335101	-	120	80	100 / -	8 / -	13,8 / -	
ND 8/140	70345102	70345181	140	100	100 / 50	6 / 8	10,1 / 13,5	

Loads, any direction			ND 5	ND 6	ND 8
Recommended loads, concrete C20/25	rec. N	[kN]	0,18	0,26	0,36
Recommended loads, solid brick MZ 12	rec. N	[kN]	0,16	0,22	0,30
Recommended loads, aerated concrete G2	rec. N	[kN]	0,04	0,06	0,08
Effective anchorage depth	h_{ef}	[mm]	25	30	40

Installation parameters			ND 5	ND 6	ND 8
Drill hole diameter	d_0	[mm]	5	6	8
Depth of drill hole	h_1	[mm]	35	40	50

Installation



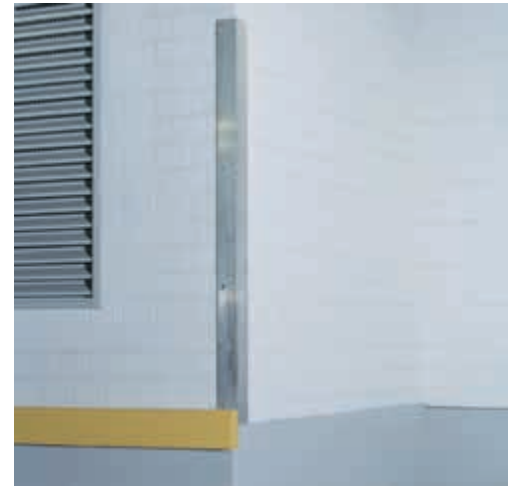
Universal Plug UD



Universal Plug UD



Universal Plug UD-K



Description

The time proven design of the Universal Plug UD guarantees reliable and safe fastenings in practically all types of base materials. To be used with woodscrews.

Applications

Electric switches, cables, curtain rails, battens, bathroom appliances, shelves, lightweight cupboards.

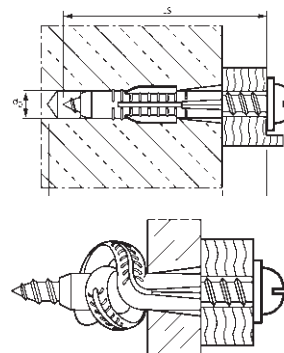
Range of loading: 0,12 kN - 1,2 kN

Universal Plug UD



- High quality plastic material
- For nearly all types of base materials

Description	Ref. No. Type UD	Ref. No. Type UD-K	Anchor-length	Screw Ø	Package content	Packages per master box		Weight per master box kg	
						UD	UD-K	UD	UD-K
UD 5/31	71010101	71010181	31	3,0-4,0	100	54	54	2,8	2,8
UD 6/36	71110101	71110181	36	4,0-5,0	100	36	36	3,0	3,0
UD 8/51	71210101	71210181	51	5,0-6,0	50	27	27	3,0	3,0
UD 10/61	71310101	71310181	61	7,0-8,0	25	54	54	4,5	4,5
UD 12/71	71410101	71410181	71	8,0-10,0	25	36	27	3,5	2,7
UD 14/75	71510101	71510181	75	10,0-12,0	20	27	27	3,5	3,5



Min. screw length

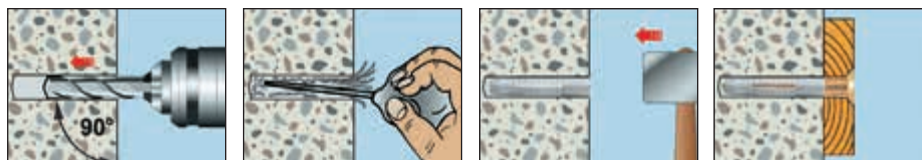
anchor length
+ thickness of plaster, tile, etc.
+ fixture thickness (accessory)
+ 1 x screw diameter

= min. screw length LS

Loads and performance data		UD 5/31	UD 6/36	UD 8/51	UD 10/61	UD 12/71	UD 14/75
Mean ultimate loads, concrete C20/25	N _{um} [kN]	0,70	1,50	3,40	3,75	4,70	5,70
Recommended loads, concrete C20/25	rec. N [kN]	0,14	0,30	0,68	0,75	0,94	1,14
Recommended loads, aircrete P4	rec. N [kN]	0,12	0,18	0,32	0,42	0,42	-
Recommended loads, hollow brick HLz12	rec. N [kN]	0,14	0,17	0,24	0,26	0,27	-
Recommended loads, gypsum plasterboard 12,5 mm	rec. N [kN]	0,12	0,14	0,2	0,2	0,22	0,44 ¹⁾
Effective anchorage depth	h _{ef} [mm]	31	36	51	61	71	75
Installation parameters							
Drill hole diameter	d _o [mm]	5	6	8	10	12	14
Depth of drill hole	h ₁ [mm]	40	45	60	75	85	90

¹⁾ 2 x gypsum plasterboard 12,5 mm
Aerated concrete: Use 1 mm smaller drill bit; hollow base materials: Drill without hammer action.

Installation



Safety Nail DZ



Safety Nail DZ-N



Safety Nail DZ-O



Description

The Safety Nail DZ is a hammer-in steel anchor for cracked and non-cracked concrete, with fire resistance classification, vandal-proof. Supplied pre-assembled .

Applications

Suspended ceilings, ventilation systems, claddings, brackets, metal sheet.

Load Range: 0,5 kN - 2,4 kN

Safety Nail DZ

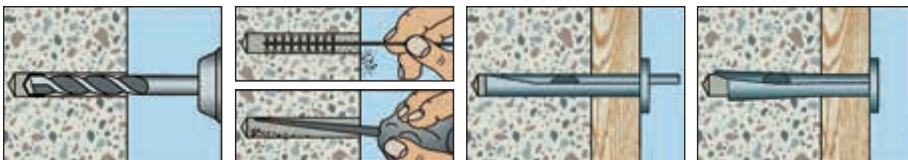


- Steel, zinc plated
- For cracked and non-cracked concrete

Description	Ref. No.	Drill hole Ø mm	Fixture- thickness mm	Eye - Ø mm	Package content pcs.	Weight per package kg
DZ-N 6 x 35	72210101	6 x 40	5	-	100	1,0
DZ-N 6 x 65	72230101	6 x 40	35	-	100	1,8
DZ-O	72250101	6 x 45	-	9	100	2,5

Loads and performance data			DZ-N 6x35	DZ-N 6x65	DZ-O
			concrete C20/25		
Recommended loads, any direction	rec. N/V	[kN]	2,4	2,4	0,5
Maximum tension loads					
According to fire resistance class	R 30	[kN]	0,8	0,8	-
According to fire resistance class	R 60	[kN]	0,7	0,7	-
According to fire resistance class	R 90	[kN]	0,6	0,6	-
According to fire resistance class	R 120	[kN]	0,4	0,4	-
Spacing and edge distance					
Effective anchorage depth	h_{ef}	[mm]	32	32	33
Minimum spacing	s_{min}	[mm]	130	130	200
Minimum edge distance	c_{min}	[mm]	100	100	150
Minimum thickness of concrete slab	h_{min}	[mm]	80	80	100
Installation parameters					
Drill hole diameter	d_o	[mm]	6	6	6
Depth of drill hole	h_1	[mm]	40	40	45

Installation



Drywall Plug GKD



Description

The Drywall Plug GKD is a selfdrilling metal plug with twin cutting tip for fastening into drywall. Suitable for screws of Ø 4 to 4,5 mm.

Applications

Fixing of switches, curtain rods, wall cupboards, lamps, cable ducts, skirting boards.

Range of loading: 0,10 - 0,15 kN

Drywall Plug GKD



→ Self-drilling plug for drywall

→ Perfect centering tip

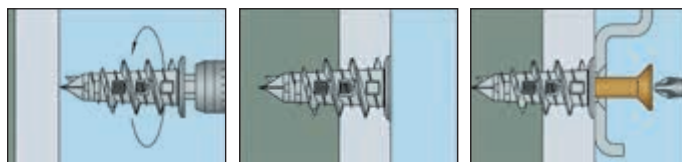
Description	Ref. No.	Anchor-length mm	Suitable for screws mm	Package content pcs.	Weight per package kg	Content per master box pcs.
GKD 39	37305001	39	Ø 4,0 - 4,5	100	0,68	2400

Loads and performance data

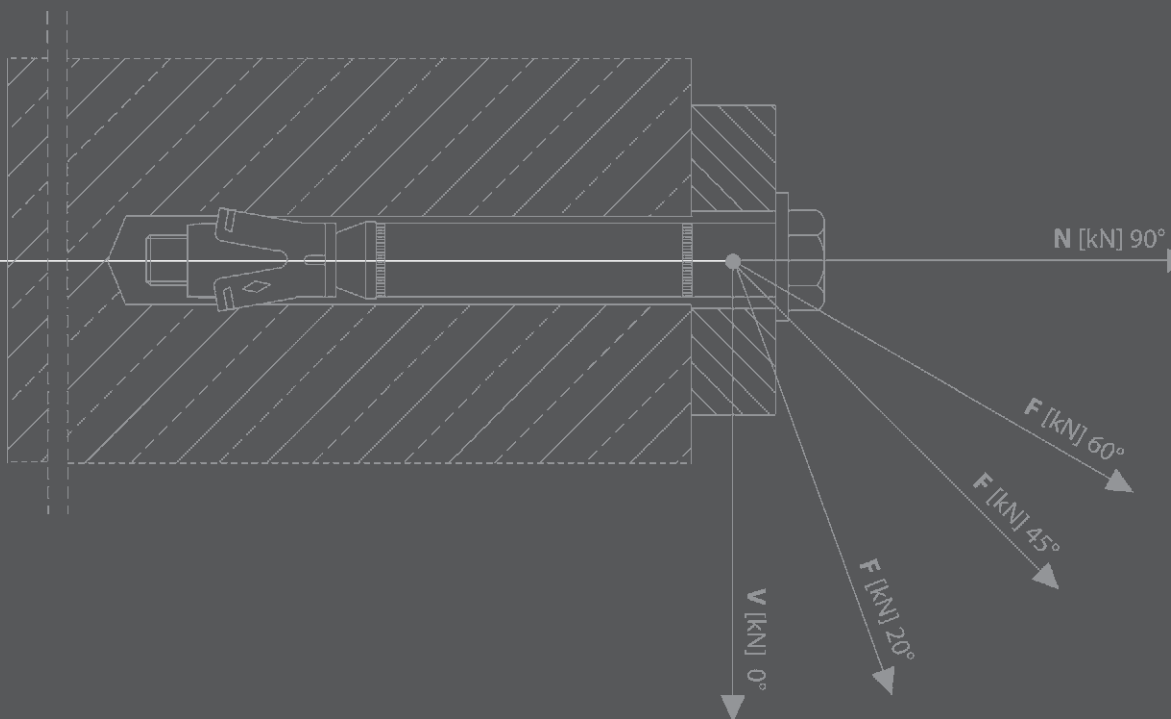
GKD 39

Mean ultimate loads, drywall d=12,5mm	N _{um}	[kN]	0,45
Mean ultimate loads, aerated concrete LC 25/28	N _{um}	[kN]	0,40
Mean ultimate loads, gypsum panel	N _{um}	[kN]	1,00
Recommended loads, drywall d=12,5mm	rec.N	[kN]	0,10
Recommended loads, aerated concrete LC 25/28	rec.N	[kN]	0,10
Recommended loads, gypsum panel	rec.N	[kN]	0,15

Installation



Service





Mechanical Heavy Duty Anchors

Chemical Anchors

Light Duty Anchors

Service

MKT Anchor Design Software



- Easy and fast design of anchoring connections
- Clear input, detailed printout
- Design according to CC-method, ETAG annex C

Software for an easy and fast design of anchoring connections.

The software:

- Easy and clear input
- Detailed display of results
- For single anchors and anchor groups, small edge distances, spaced fixings
- Detailed printout

Design according to European design guideline :

- Guideline for European Technical Approval of Metal Anchors, ETAG 001, Annex C
- Guideline for European Technical Approval of Metal Anchors, ETAG 001, Part 6 (multiple use)
- Technical Report TR 020 (Design of Anchorages in Concrete Concerning Fire Resistance)
- Technical Report TR 029 (Design of Bonded Anchors)
- Design of fatigue loads according to Z-21.3-1906

PC requirements:

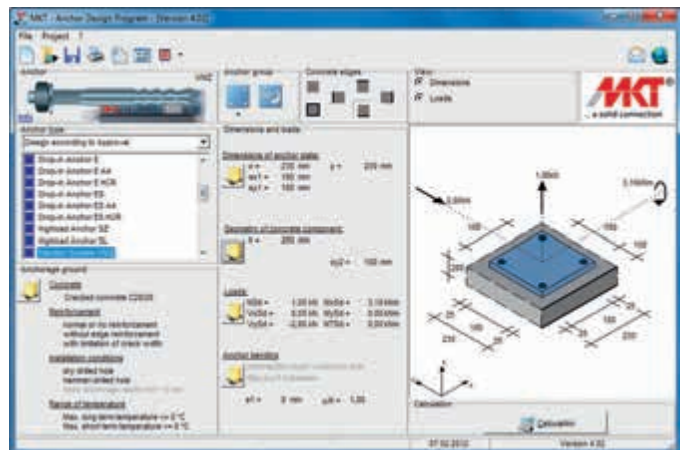
- Windows 2000 / XP / Vista / Windows 7
- Screen resolution min. 600 x 800 pixel

Please order our MKT software or use our free download service at www.mkt.de

MKT Anchor Design Software 4.02

new in 4.02:

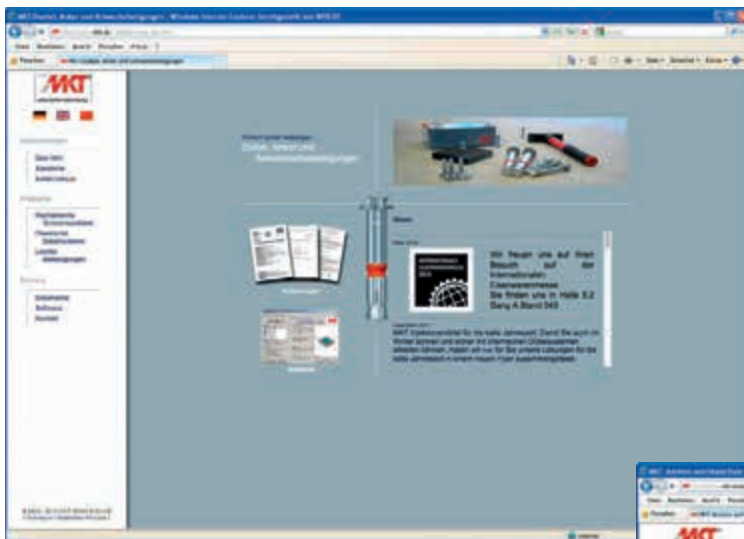
- Injection System VMZ dynamic for anchorings with fatigue loads
- Injection System VME with variable effective anchorage depth according to TR 029



 → Product information

 → Download

 → Support

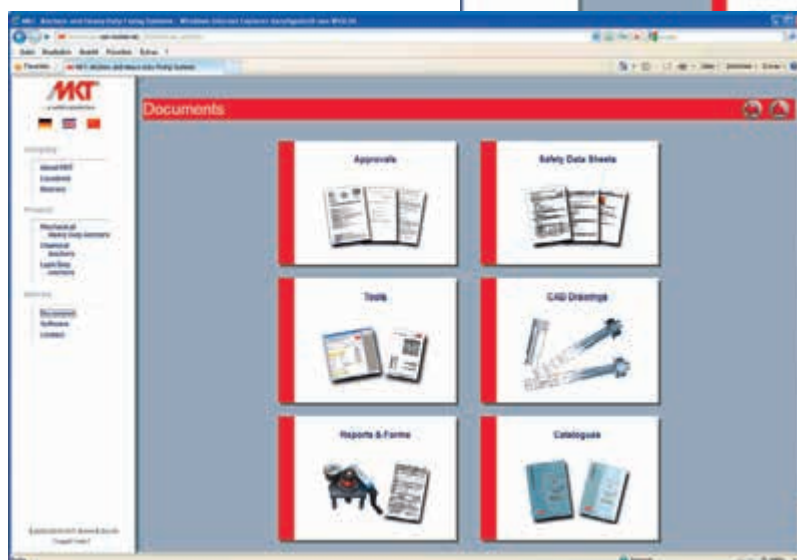
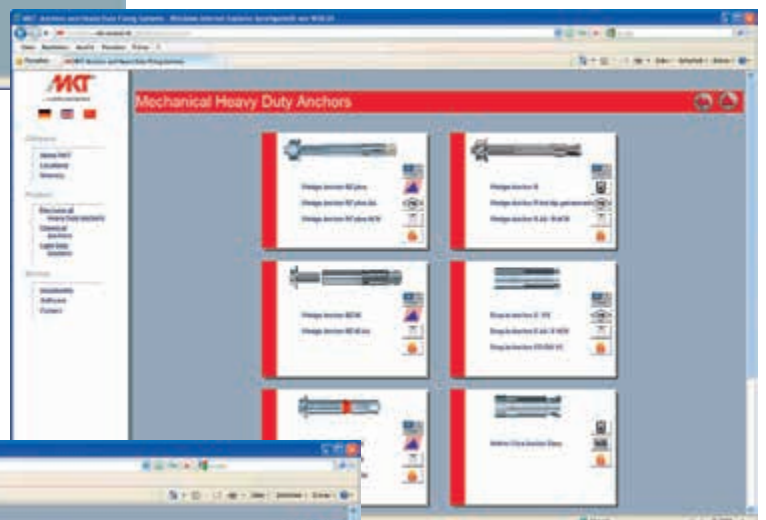


Product information

Contains detailed information and technical data for our product range.

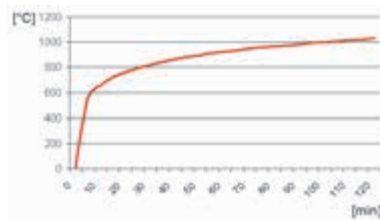
Download









Software, approvals, certificates and data sheets can be downloaded from our website.









Fire Resistant Anchor Systems

Tested according to standardized temperature curve (ISO 834, DIN EN 1363-1: 1999-10, DIN 4102-2: 1977-09) in cracked concrete, exposed to open flames, without fire protection. The full IBMB test reports are available on request.

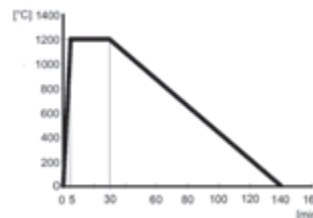



Anchor system	IBMB test report / approval	Size	Maximum tension load [kN] in fire tests according to DIN 4102-2 for the fire resistance classes			
			F 30 (30 min)	F 60 (60 min)	F 90 (90 min)	F 120 (120 min)
Wedge Anchor BZ plus Steel, zinc plated 	ETA-99/0010	M 8	1,30	1,10	0,80	0,70
		M 10	2,20	1,80	1,40	1,20
		M 12	3,00	2,80	2,40	2,20
		M 16	6,00	5,20	4,40	4,00
		M 20	9,00	8,20	6,90	6,30
Wedge Anchor BZ plus A4/HCR Stainless steel A4/316, Stainless steel 1.4529 	ETA-99/0010	M 8	1,30	1,30	1,30	1,00
		M 10	2,30	2,30	2,30	1,80
		M 12	3,00	3,00	3,00	2,40
		M 16	6,30	6,30	6,30	5,00
Wedge Anchor BZ-IG Steel, zinc plated 	ETA-02/0002	M 6	0,70	0,60	0,50	0,40
		M 8	1,40	1,20	0,90	0,80
		M 10	2,50	2,00	1,50	1,30
		M 12	3,70	2,90	2,20	1,80
Wedge Anchor BZ-IG A4/HCR Stainless steel A4/316, Stainless steel 1.4529 	ETA-02/0002	M 6	1,3	1,3	1,0	0,5
		M 8	2,3	2,3	2,1	1,3
		M 10	3,0	3,0	3,0	2,4
		M 12	5,0	5,0	5,0	4,0
Wedge Anchor B, B-U Steel, zinc plated 	3174/1748-1	M 6, $h_{ef} = 40\text{mm}$	0,90	0,50	0,30	0,25
		M 8, $h_{ef} = 44\text{mm}$	1,40	0,80	0,50	0,40
		M 10, $h_{ef} = 48\text{mm}$	2,20	1,20	0,80	0,60
		M 12, $h_{ef} = 65\text{mm}$	3,20	1,80	1,20	0,90
		M 16, $h_{ef} = 82\text{mm}$	6,00	3,40	2,20	1,70
		M 20, $h_{ef} = 100\text{mm}$	10,00	5,25	3,60	2,75
Wedge Anchor B A4 Stainless steel A4/316 	3174/1748-1	M 6, $h_{ef} = 40\text{mm}$	0,90	0,50	0,30	0,25
		M 8, $h_{ef} = 44\text{mm}$	2,30	1,70	1,40	1,30
		M 10, $h_{ef} = 48\text{mm}$	3,60	2,60	2,20	2,00
		M 12, $h_{ef} = 65\text{mm}$	5,20	3,80	3,20	2,90
		M 16, $h_{ef} = 80\text{mm}$	9,70	7,00	6,00	5,40
		M 20, $h_{ef} = 100\text{mm}$	15,00	10,20	8,20	7,00
Drop-in Anchor E Steel, zinc plated / Stainless steel A4/316 with screw 5.6 (or higher) or Stainless steel A4/316 *)  *) Standard thread version, see test report	3174/1748-2	M 6	1,70	0,70	0,40	0,30
		M 8	1,70	0,70	0,40	0,30
		M 8 x 40	3,00	1,50	0,80	0,60
		M 10 x 30	4,70	2,40	1,30	1,00
		M 12	6,90	3,50	1,80	1,40
		M 16	12,50	5,60	3,50	2,50
		M 20	18,00	8,50	5,50	4,00
Chemical Anchor V Steel, zinc plated / Stainless steel A4/316 and 1.4529 	3019/272/07	M 8	2,30	1,29	0,79	0,53
		M 10	3,64	2,04	1,30	1,00
		M 12	5,26	3,07	2,00	1,50
		M 16	9,79	5,72	3,68	2,67
		M 20	15,28	8,93	5,75	4,16
		M 24	22,01	12,86	8,28	6,00

Anchor system	IBMB test report / approval	Size	Maximum tension load [kN] in fire tests according to DIN 4102-2 for the fire resistance classes			
			F 30 (30 min)	F 60 (60 min)	F 90 (90 min)	F 120 (120 min)
Hollow Core Anchor EASY Steel, zinc plated 	Z-21.1-1785	M 6	0,71	0,59	0,47	0,34
		M 8	1,23	0,99	0,74	0,62
		M 10	1,95	1,56	1,17	0,98
		M 12	2,84	2,27	1,71	1,42
Highload Anchor SZ Steel, zinc plated 	ETA-02/0030	M 6	1,00	0,80	0,60	0,40
		M 8	1,90	1,50	1,00	0,80
		M 10	4,00	3,20	2,10	1,50
		M 12	6,30	4,60	3,00	2,00
		M 16	8,80	8,60	5,00	3,10
		M 16L	8,80	8,60	5,00	3,10
Schwerlastanker SZ A4 Edeldahl A4 	ETA-02/0030	M 8	2,30	2,30	2,30	1,80
		M 10	4,00	4,00	4,00	2,80
		M 12	6,40	6,40	6,40	4,10
		M16	9,00	9,00	9,00	7,20
Injection System VMU Steel, zinc plated /Stainless steel A4/316 and 1.4529 	3681/0206	M 8	1,90	0,85	0,55	0,40
		M 10	4,50	2,10	1,35	1,00
		M 12	6,00	3,00	2,00	1,50
		M 16	11,00	6,60	4,90	4,00
		M 20	16,00	9,00	6,40	5,00
		M 30	31,52	18,25	11,62	8,31
Injection System VMZ Steel, zinc plated /Stainless steel A4/316 and 1.4529 	3191/5064	≥ 50 M 8	3,00	0,30	---	---
		≥ 60 M 10	7,00	0,90	0,30	---
		≥ 80 M 12	10,00	2,80	1,30	0,80
		≥ 125 M 16	12,00	6,30	4,40	3,40
		≥ 170 M 20	18,70	9,90	6,90	5,30
Injection System VME Rebar BST 500 S; Tension Anchor ZA 	Z-21.8-1872	The tension load is dependant on the embedment depth. Check the technical approval for details.				

Fire Resistant Anchor Systems in tunnels

Tested according to ZTV tunnel temperature curve in cracked concrete, exposed to open flames, without fire protection.
The full IBMB test reports are available on request.



Anchor system	IBMB test report	Size	Maximum tension load in fire tests according to ZTV tunnel temperature curve	
			Anchorage depth	Tension load [kN]]
Wedge Anchor BZ plus HCR Stainless steel 1.4529 	3212/1206-6	M 8	46 mm	1,00
		M 10	60 mm	1,90
		M 12	65 mm	3,00
		M 16	85 mm	5,50
		M 20	100 mm	6,80



MKT Metall-Kunststoff-Technik
GmbH & Co.KG
Auf dem Immel 2
67685 Weilerbach, Germany

Phone +49(0)6374/9116-0
Fax +49(0)6374/9116-60
info@mkt.de
www.mkt.de

... a solid connection